

AUTOMOTIVE TECHNOLOGY 2

Penulis:

**AHMAD TAUFIQ WAFI B. ABDUL GHANI
AB HAKIM B. AB HALIM
MOHD FIKRI B. MOHD SOFFIAN**

Kejuruteraan Mekanikal



DJA30023

AUTOMOTIVE TECHNOLOGY 2

AUTOMOTIVE
TECHNOLOGY



AUTOMOTIVE TECHNOLOGY

All rights reserved. No part of this publication may be reproduced, used for editing or stored in a retrieval system, or transmitted, in any forms or by any means, electronic, mechanical, photocopying or otherwise without obtaining written permission from Department of Polytechnic Education, Ministry of Higher Education.

Ahmad Taufiq Wafi Abd. Ghani, 1981-
AUTOMOTIVE TECHNOLOGY. 2 / Penulis: AHMAD TAUFIQ WAFI BIN ABD GHANI,
AB HAKIM BIN AB HALIM, MOHD FIKRI BIN MOHD SOFFIAN.

Mode of access: Internet
eISBN 978-967-2897-38-5

1. Automobiles--Design and construction.
2. Government publications--Malaysia.
3. Electronic books.

I. Ab. Hakim Ab. Halim, 1986-. II. Mohd. Fikri Mohd. Soffian, 1986-.
III. Title.
629.23

AUTOMOTIVE
TECHNOLOGY

PUBLISHED BY:

Politeknik Port Dickson

KM 14, Jalan Pantai, 71050 Si Rusa

Port Dickson, Negeri Sembilan

AUGUST 2021

Copyright Each part of this publication may not be reproduced or distributed in any forms by any means or retrieval system without prior written permission.

ACKNOWLEDGEMENT

PATRON

Mohamad Isa Bin Azhari
Director, Politeknik Port Dickson

ADVISORS

Dr. Nor Haniza Binti Mohamad
Deputy Director (Academic), Politeknik Port Dickson
Razali Bin Bakri
Head of Mechanical Engineering Department, Politeknik Port Dickson

EDITOR

Mohd Izad Affendy Bin Mohd Yusof
Head of Automotive Programme, Politeknik Port Dickson

FACILITATORS

Nin Hayati Binti Mohd Yusof
Che Azlina Binti Che Norohoseni
Ragunathan AL Jayaraman

WRITERS

Ahmad Taufiq Wafi Bin Abd Ghani
Ab Hakim Bin Ab Halim
Mohd Fikri Bin Mohd Soffian

We would like to convey our utmost gratitude to the Department of Polytechnic and Community College Education particularly the E-learning and Instructional Division (BIPD) for funding our e-book project.

We hereby declare that this module is our original work. To the best of our knowledge it contains no materials previously written or published by another person. However, if there is any, due acknowledgement and credit are mentioned accordingly in the e-book.

ABSTRACT

Automotive Technology is one of the courses offered in Diploma of Mechanical Engineering (Automotive) at Politeknik Malaysia. This course provides knowledge on the concept and basic principles of three systems in automotive technology, that are Engine Management System (EMS), Air Induction System and Forced Induction System. It is hoped that students will be able to understand and explain the evolving technology trends in automotive systems with this digital material. The technique of compiling this book is simple, concise and graphically informative. Each title is equipped with sample questions and answers to facilitate the learning process. Today's digital learning technology is one of the attraction for students to explore knowledge without borders.

AUTOMOTIVE
TECHNOLOGY

TABLE OF CONTENTS

1.0 Engine Management System (EMS)

| | |
|---|---|
| 1.1 Development of engine control system | |
| a. Types of engine management systems | 3 |
| b. Requirements and purpose of engine management system | 4 |
| c. Function and component of Sub-system of engine management system | 6 |
| i. Air induction system | |
| ii. Fuel management system | |
| iii. Control System/sensor system | |
| d. Types, function and location of sensors | 8 |
| i. Oxygen sensor | |
| ii. Air intake temperature sensor | |
| iii. Engine temperature sensor | |
| iv. Throttle position sensor | |
| v. Air flow sensor | |
| vi. Mass air flow sensor | |
| vii. Crankshaft sensor | |
| viii. Manifold pressure sensor | |
| ix. Knock sensor | |
| x. Engine oil sensor | |
| xi. Engine speed sensor | |

| | | |
|----|---|----|
| e. | Types, function and location of actuators | 27 |
| | i. Fuel injector | |
| | ii. Cold start injector | |
| | iii. Fuel pump | |
| | iv. Fuel filter | |
| | v. Fuel tank | |
| | vi. Fuel pressure regulator | |
| | vii. Pulsation damper | |
| | viii. Spark Plug | |
| | ix. Idling speed control valve | |
| | x. Radiator Fan | |
| f. | Type of fuel injection systems, its components and its functions | 37 |
| | i. Single point / throttle body injection | |
| | ii. Port or multipoint fuel injection | |
| | iii. Sequential fuel injection | |
| | iv. Direct Injection | |
| | Questions and Answers | 41 |

2.0 Forced Induction System

| | |
|--|----|
| 2.1 Function, construction and operation of forced induction system and its components | |
| a. Forced induction system | 46 |
| b. Turbocharged system | 50 |
| i. Blow off valve | |
| ii. Waste gate | |
| iii. Intercooler | |
| c. Supercharged system | 58 |
| d. Advantages and disadvantages of turbocharger and supercharger | 61 |
| Questions and Answers | 62 |

3.0 Emission Control System

| | |
|--|----|
| 3.1 Types of vehicle emission sources | 66 |
| a. Exhaust emission pollutants and effects to human health | |
| i. Hydrocarbon, HC | |
| ii. Carbon Monoxide, CO | |
| iii. Oxide of nitrogen, NO _x | |
| iv. Particulate Matter, PM | |
| v. Sulfur Oxide, SO _x | |
| b. The fuel evaporation sources | 72 |
| c. The “blow-by gas” | 73 |

3.2 Explain the emission control systems

| | | |
|----|--|----|
| a. | Types of emission control systems | 74 |
| | i. Catalytic Converter | |
| | ii. Exhaust Gas Recirculation Systems, EGR | |
| | iii. Positive Crankcase Ventilation System, PCV | |
| | iv. Evaporative Emission Control System | |
| b. | The components name, function and location | 81 |
| c. | Overall layout of emission control systems. | 84 |
| d. | Secondary Air Injection System | 85 |
| | Questions and Answers | 86 |

CHAPTER 1

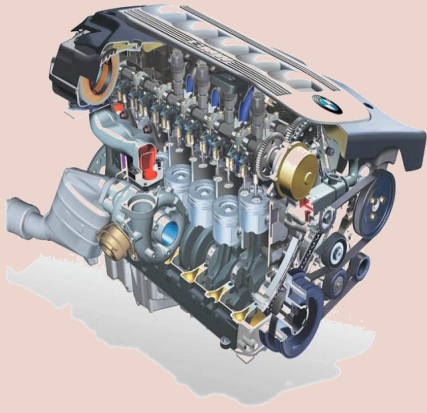

ENGINE MANAGEMENT SYSTEM (EMS)

OBJECTIVES

ENGINE MANAGEMENT SYSTEM

1

1) Types of engine management

2

2) Requirements and purpose of engine management system

3

3) Function & component of Sub-system of EMS
a. Air Induction System
b. Fuel Management System
c. Control system / sensor system

4

4) Types, function & location of actuators

5

5) Different types of fuel injection systems, its components and its functions
a. Continuous Injection (K-Jetronic)
b. Multi Point Injection (L-Jetronic)
c. D-EFI Injection
d. Direct Injection

TYPES OF EMS

ENGINE MANAGEMENT SYSTEM

1



Non Programmable EMS

- The majority of Engine Management Systems in production vehicles are not programmable, meaning that the maps that determine fueling and ignition settings are pre-programmed and cannot be modified by the owner.
- From a manufacturer's perspective, this makes sense because the engine then runs within the approved parameters, keeping pollutants and fuel economy within established limitations.

2



Programmable EMS

- Because they must be fitted to a variety of different engine installations in a range of states of tune, all aftermarket Engine Management Systems are programmable.
- The EMS would be useless for aftermarket applications if the map settings could not be altered.
- Certain manufacturers of these systems discourage home mapping and only allow it to be done by authorised dealers.



Remap vs Retune ??

ENGINE MANAGEMENT SYSTEM (EMS)

- EMS – is a computer software that regulates the speed, load, and temperature of an engine, as well as producing the ignition spark at the appropriate time
- computer & electronics are used to control the operation of engines
- basic parts of an electric control system in Engine Management System (EMS)

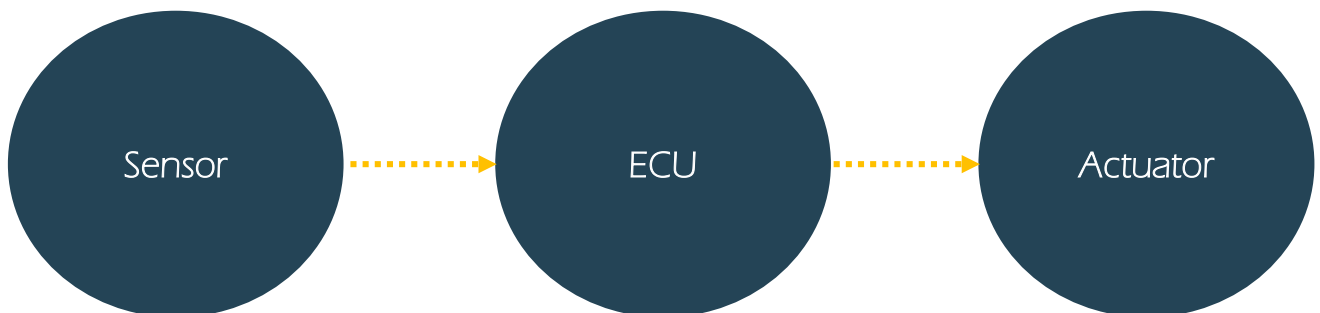

- An electronic device used to detect, collect data & send the data/signal to ECU
- Electronic board used to analyse & control the data received by sensors and send the instructions signal to actuators
- Receive the instruction from ECU to do the directed job.
- A mechanical device that is used to move or control a machine or system.
- It transfers energy, which is commonly conveyed by air, electric current, or liquid, into motion.

ENGINE MANAGEMENT SYSTEM OVERVIEW

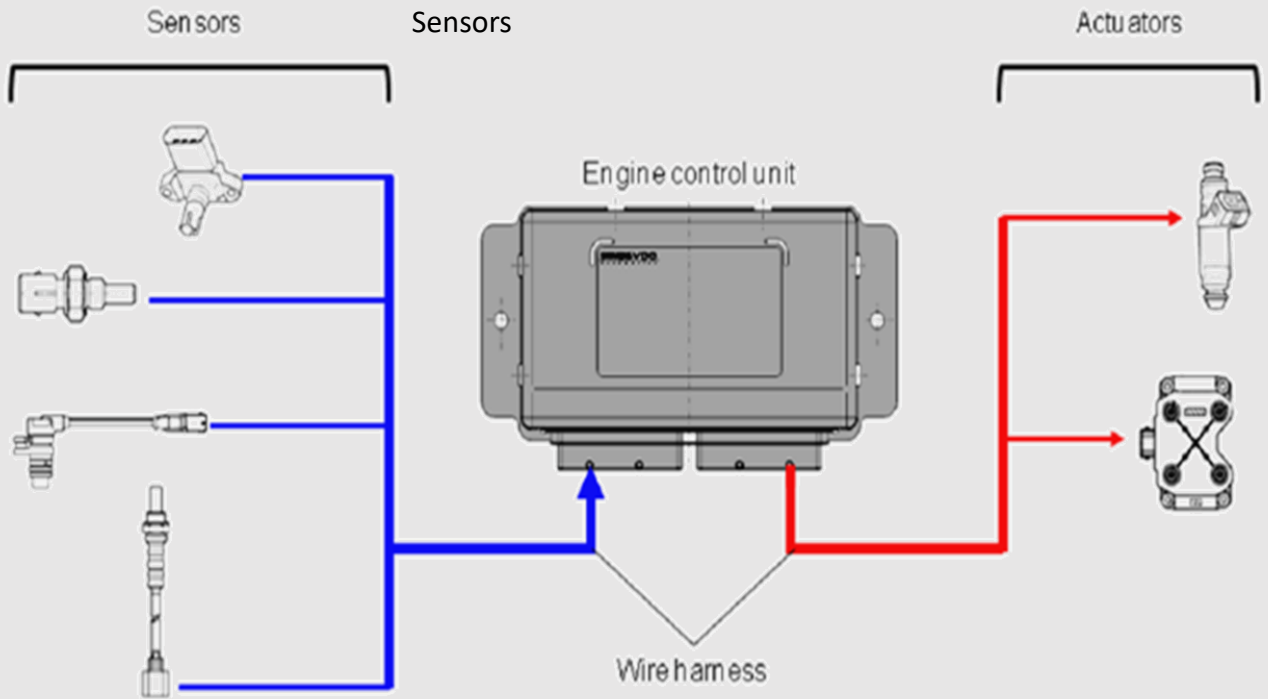

ENGINE MANAGEMENT SYSTEM

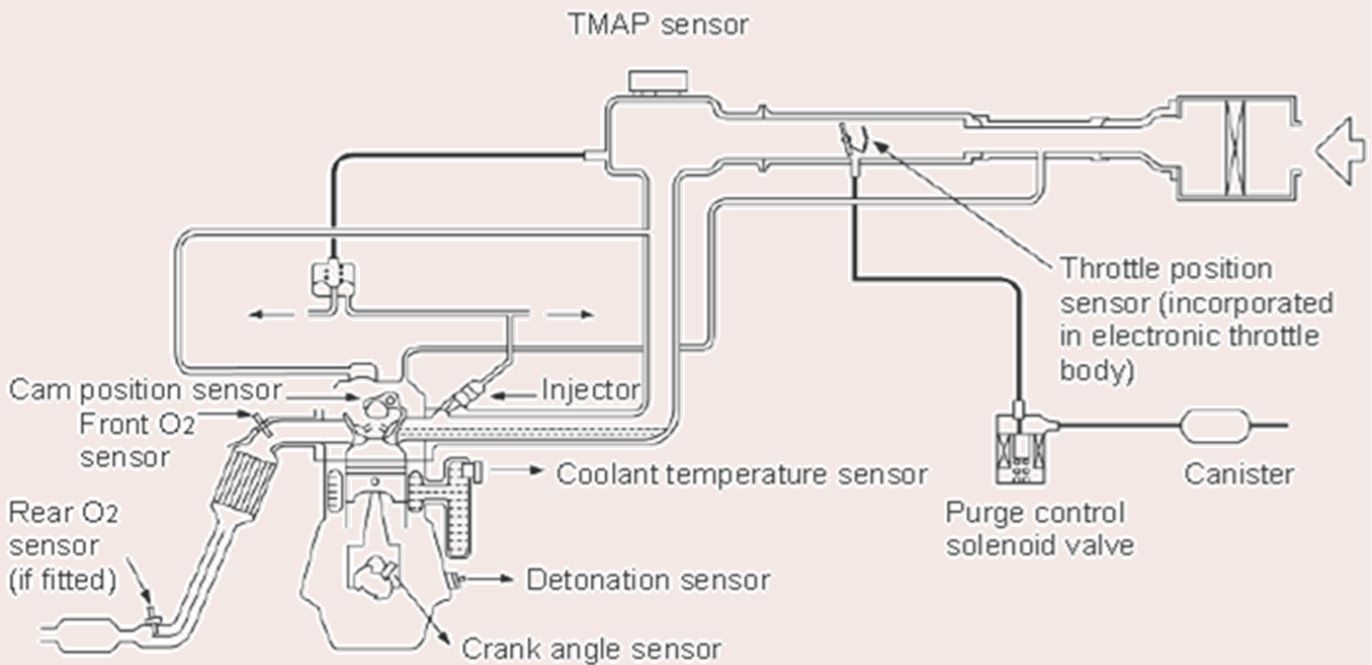

What is an engine management system and how does it work?

SUB SYSTEM EMS

AIR INDUCTION SYSTEM

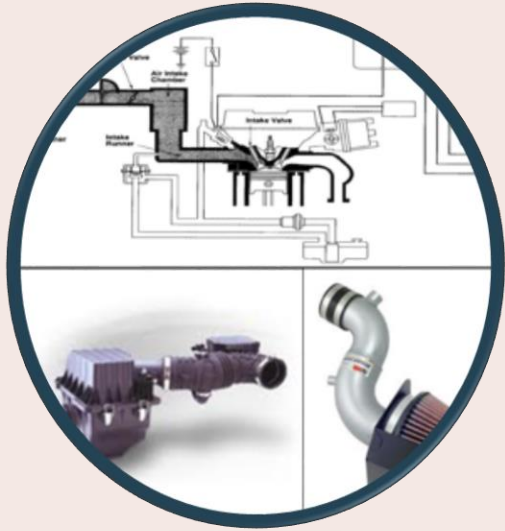

- Increase the combustion and efficiency of an engine by providing the proper amount of air.
- Delivery proper amount of air accurately to all cylinders at proper times in the engine.
- The 3 major components – blower, turbocharger & supercharger.

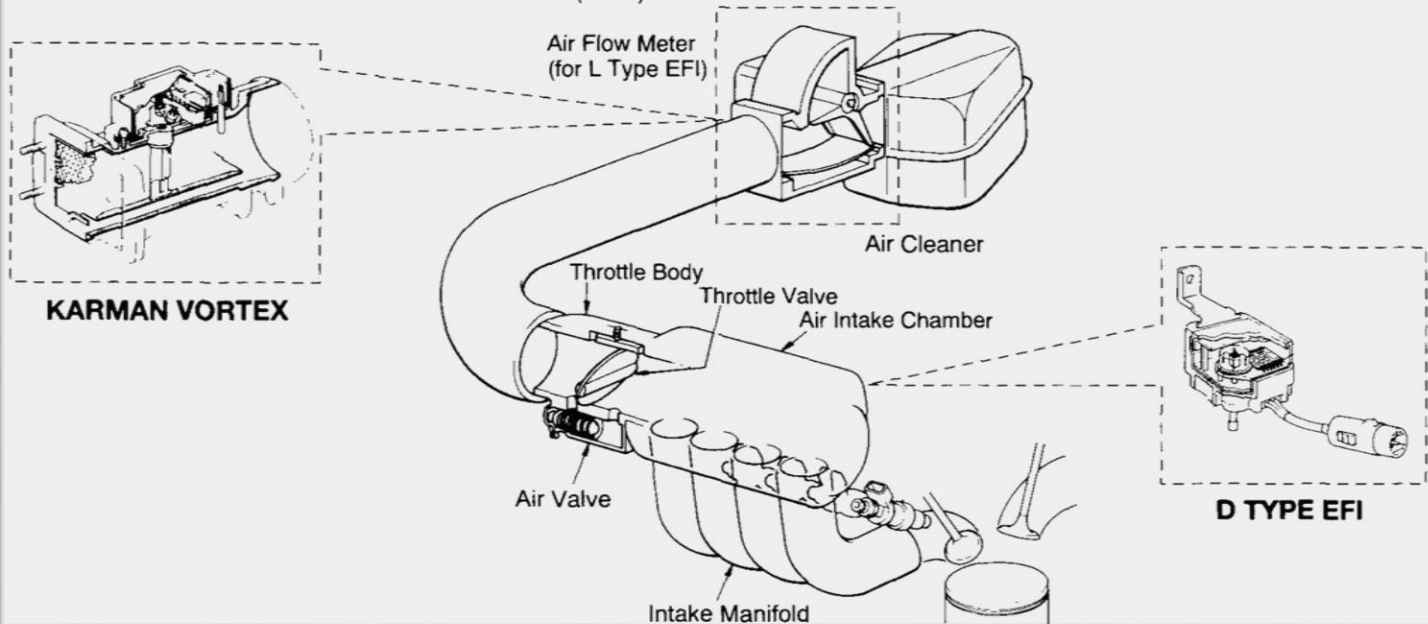
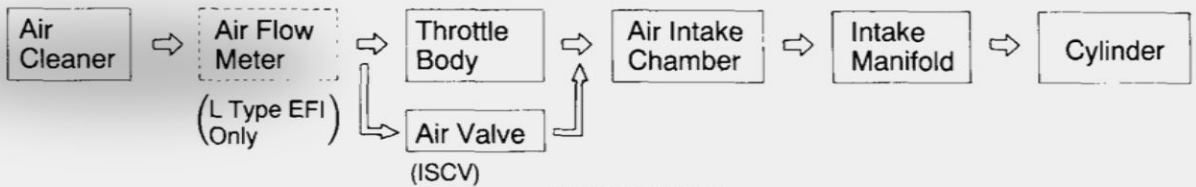

How does an engine management system work?



An EMS is a self-contained, custom-built computer that manages the operation of an engine by monitoring engine speed, load, and temperature, supplying the ignition spark at the appropriate moment for the conditions, and metering the fuel to the engine in the precise amount required.

COMPONENTS

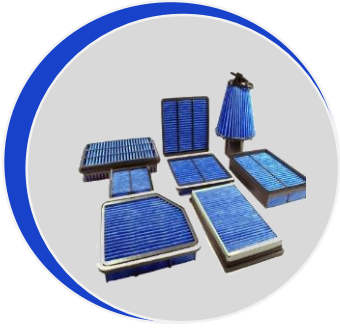

AIR FILTER

- To clean outside air before entering into the cylinder.
- The first part of an induction system components

AIR FILTER METER

- The mass flow rate of air entering a fuel-injected internal combustion engine is measured using a mass (air) flow sensor (MAF).
- The engine control unit (ECU) needs the air mass information to balance and deliver the correct fuel mass to the engine.

THROTTLE BODY

- A butterfly valve situated between the air intake filter and the intake manifold is known as a throttle body.
- It controls the amount of air that can enter the engine dependent on the driver's input via the gas pedal.
- As more air enters the engine, more fuel is injected, resulting in increased power.
- There are two types: cable and wire.

VARIABLE INTAKE MANIFOLD

- Function: To improve power and torque throughout a wide range of engine speeds while also reducing fuel consumption.
- Having two independent intake ports, each controlled by a valve, that open two different manifolds is a common way to achieve this effect:
 - One has a short path and high engine load, for example.
 - Another that has a much longer path and runs at a lower load.

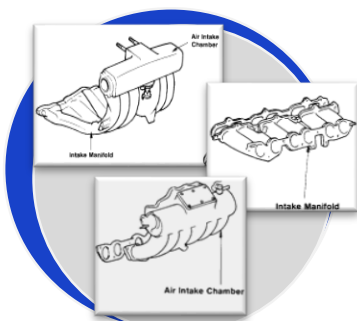
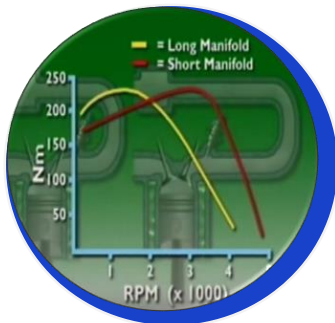

INTAKE CHAMBER & MANIFOLD

HOTWIRE MAF SENSOR

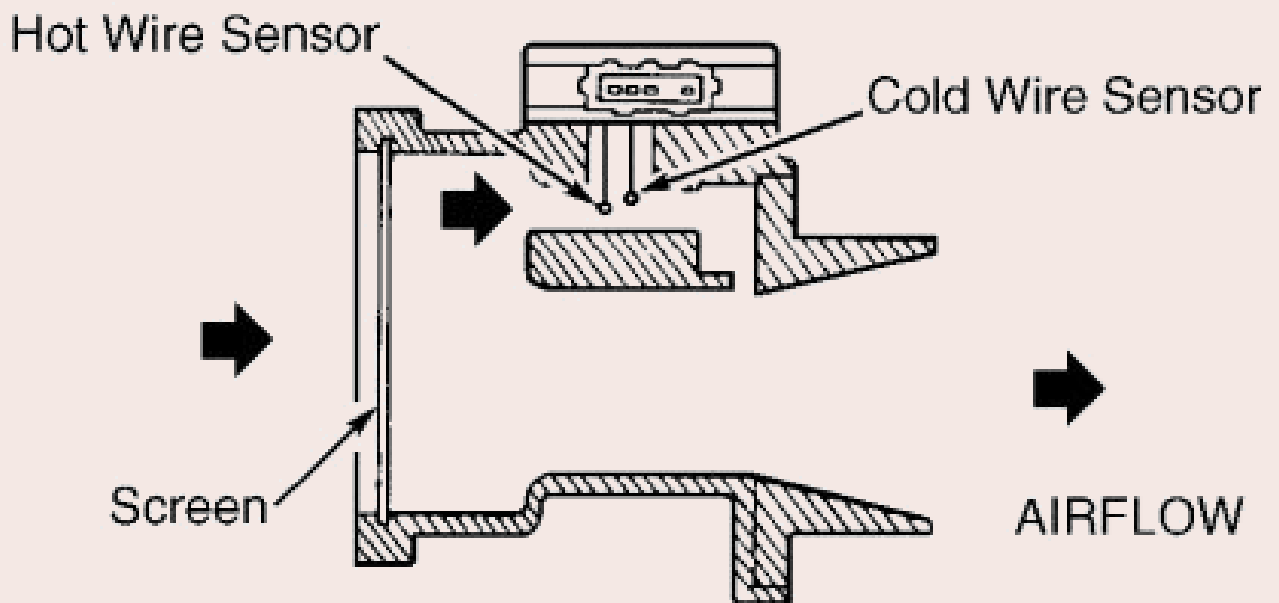

G94E31744

VANE METER MAF SENSOR

VANE AIRFLOW SENSOR

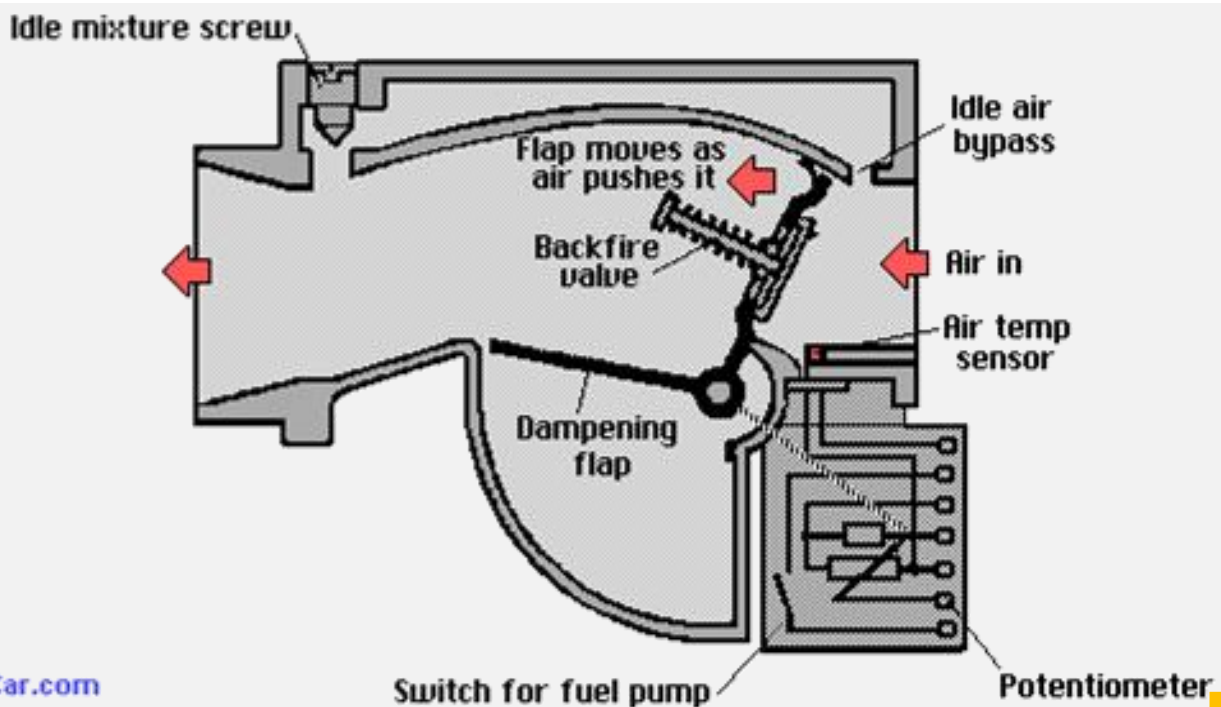

THROTTLE BY CABLE

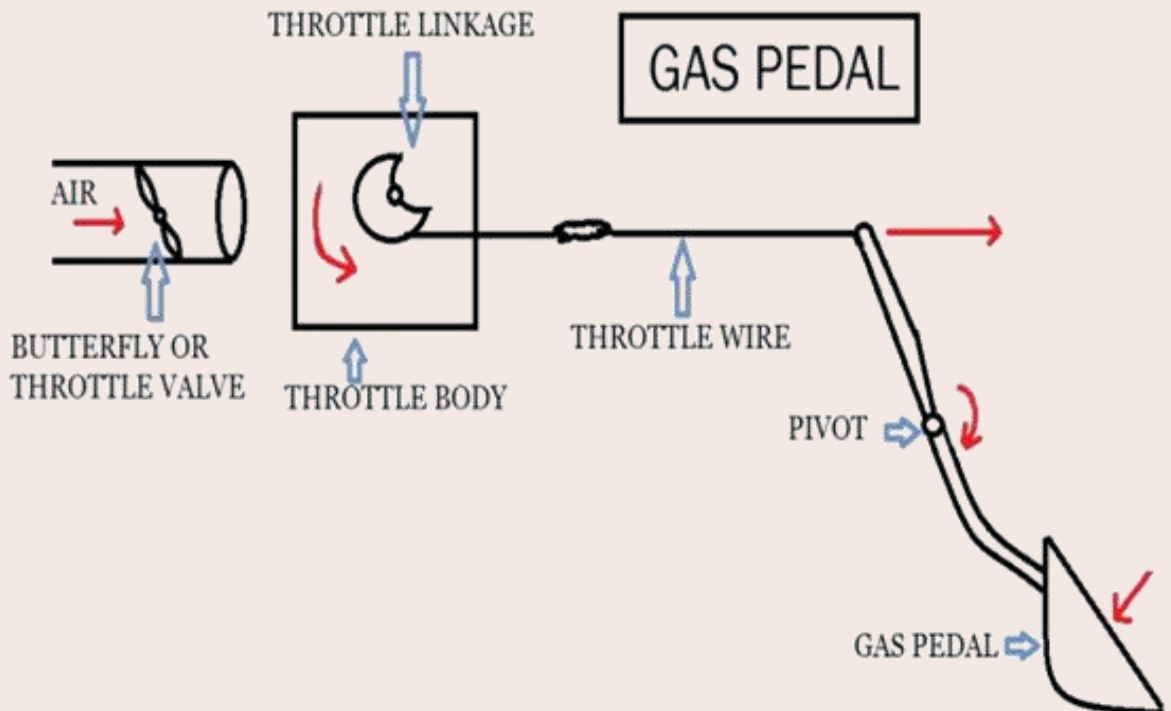

THROTTLE BY WIRE (DBW)

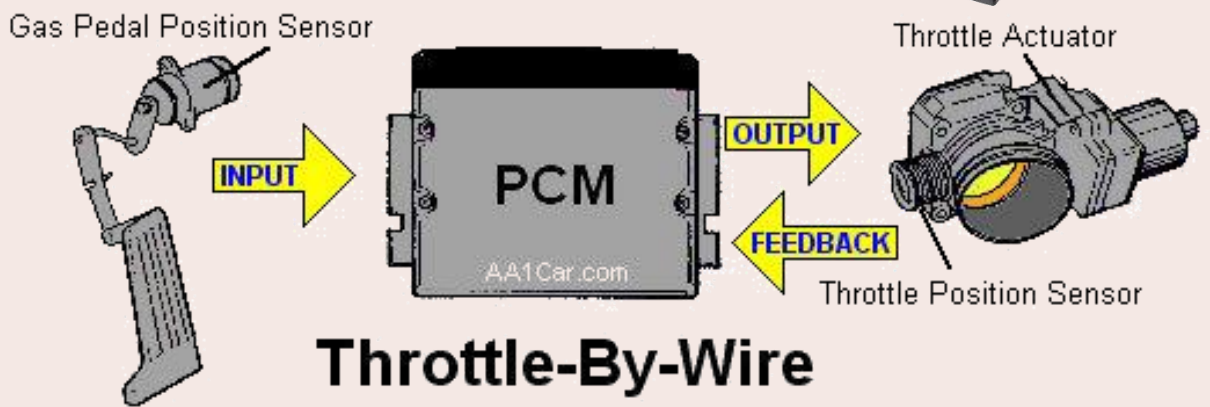
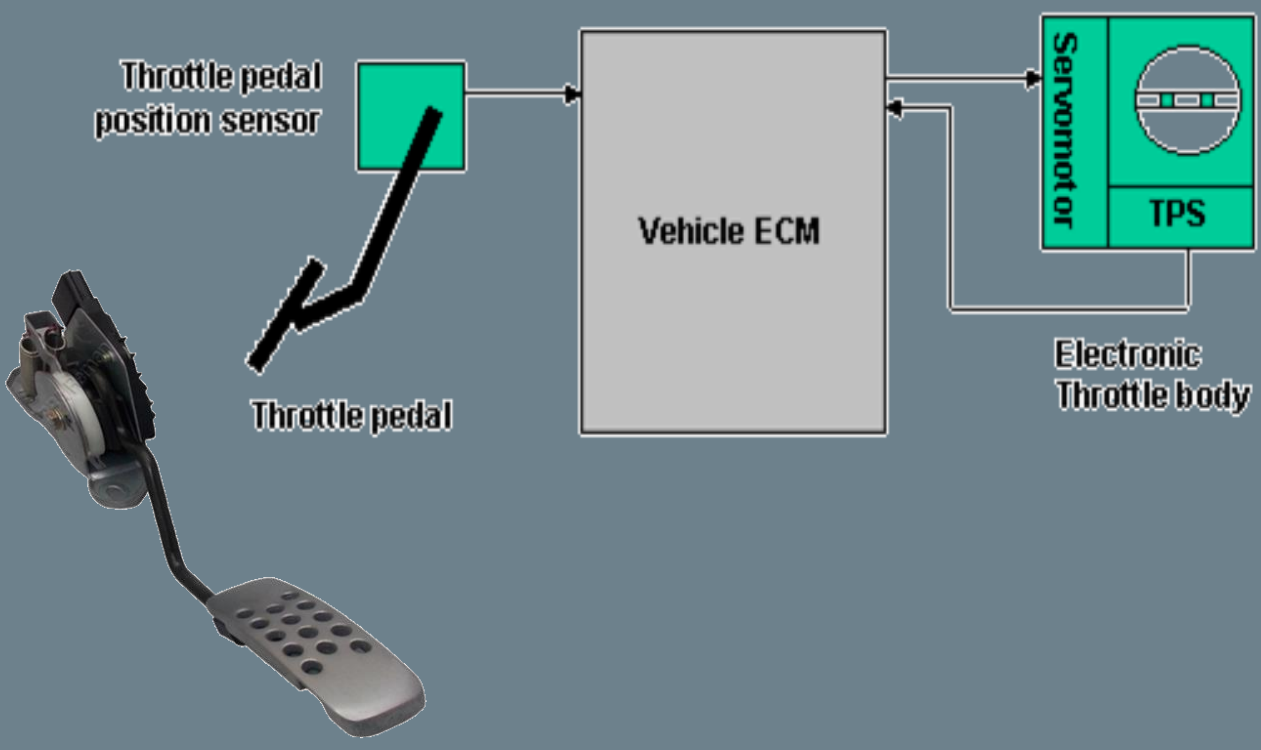

FUEL MANAGEMENT SYSTEM

- Assists the pilot in managing fuel by considering fuel flow, airspeed and winds
- Fuel supply are designed to deliver precision amounts of fuel as needed to achieve the best balance between power, fuel economy, low exhaust emissions
- The ECU takes inputs from sensors and controls fuel injectors to give the best air-fuel ratio for different engine running circumstances

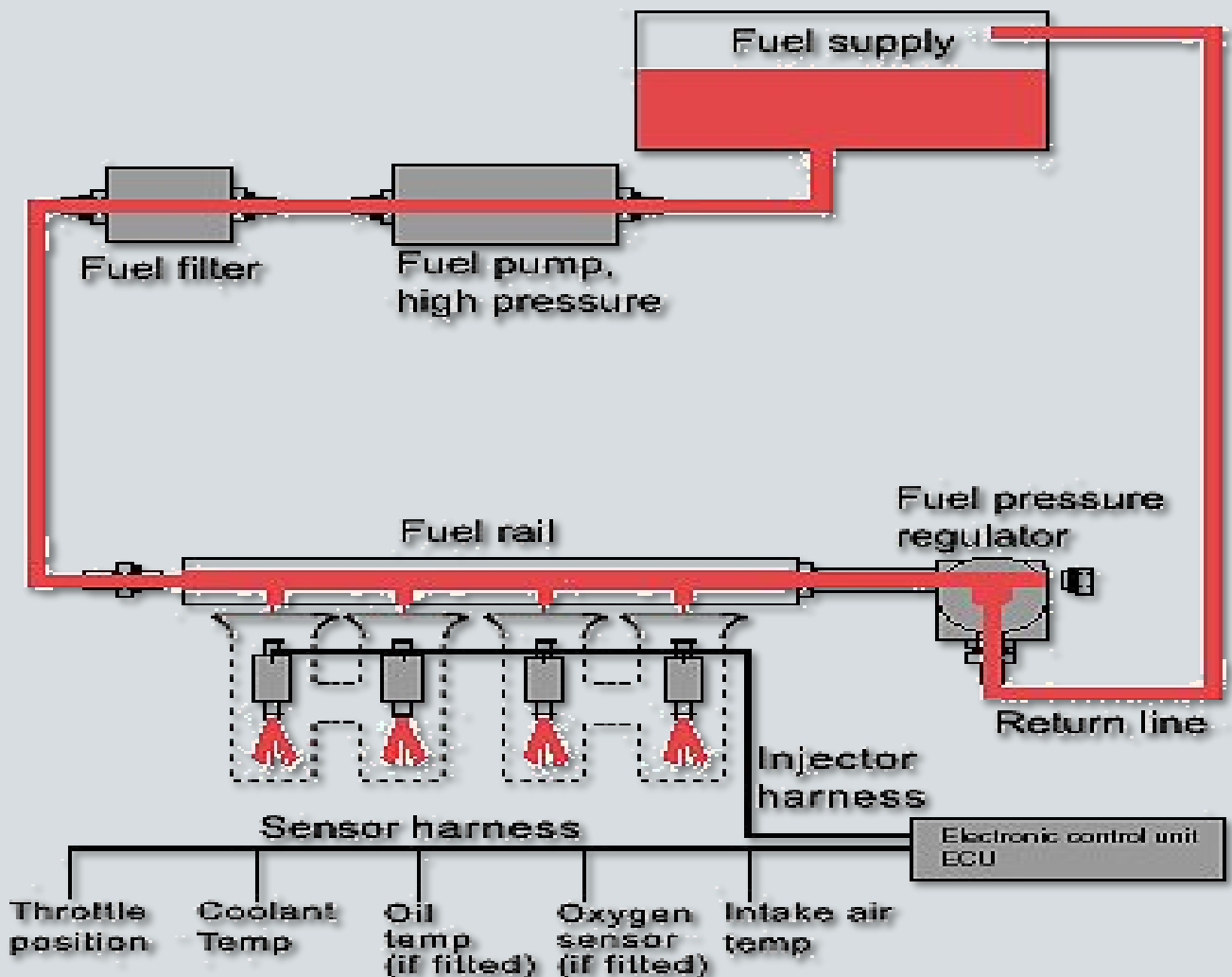

EFI COMPONENTS

1

FUEL TANK

- supplies fuel to the system

2

FUEL PUMP

- transports fuel from the tank to the system

3

FUEL FILTER

- filters the petrol/ fuel before entrance the chamber

4

FUEL RAIL/DELIVERY

- connected fuel from tank to injector.

5

INJECTOR

- sprays the fuel into combustions chamber.

6

FUEL PRESSURE REGULATOR

- to maintain the fuel pressure in EFI system.

7

FUEL RETURN LINE

- to return the waste fuel to the tank

AIR/FUEL RATIO

- The correct amount of air and fuel are present in a 'Stoichiometric' AFR to achieve a chemically complete combustion event.
- The stoichiometric A/F ratio for gasoline engines is 14.7:1, which implies 14.7 parts air to one component fuel.

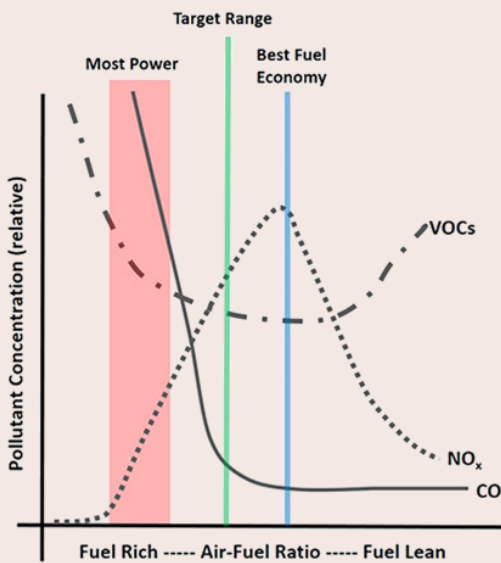
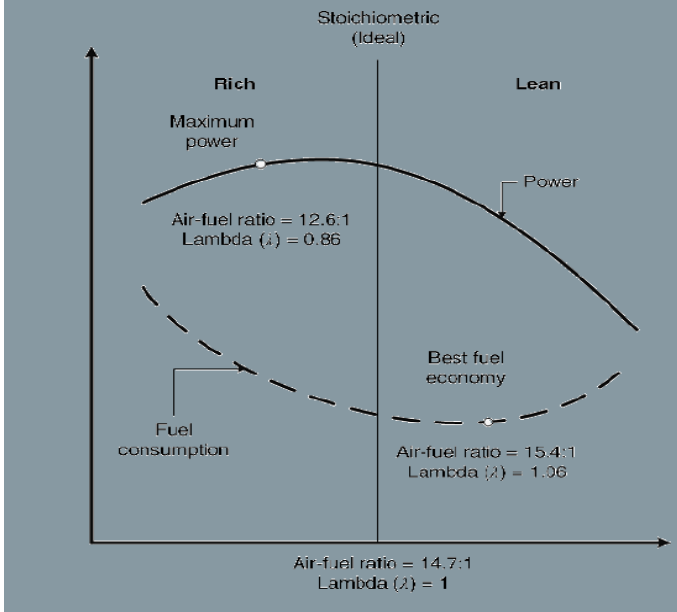

The effect of AFR on Emission

- Air flow sensor
- Intake air temperature sensor
- Barometric pressure sensor
- ECT sensor
- Throttle position sensor
- Camshaft position sensor
- Crank angle sensor
- Ignition Switch – ST
- Detonation sensor
- Vehicle Speed sensor
- Oxygen sensor (vehicle with catalytic converter)
- Mixture adjusting screw (vehicle without catalytic converter)

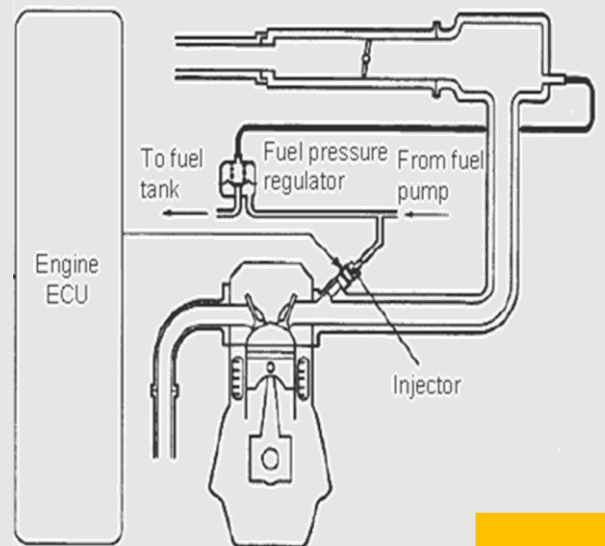

CONTROL/ SENSOR MANAGEMENT

- Detects operating condition system
- Sends data & gives information to EC

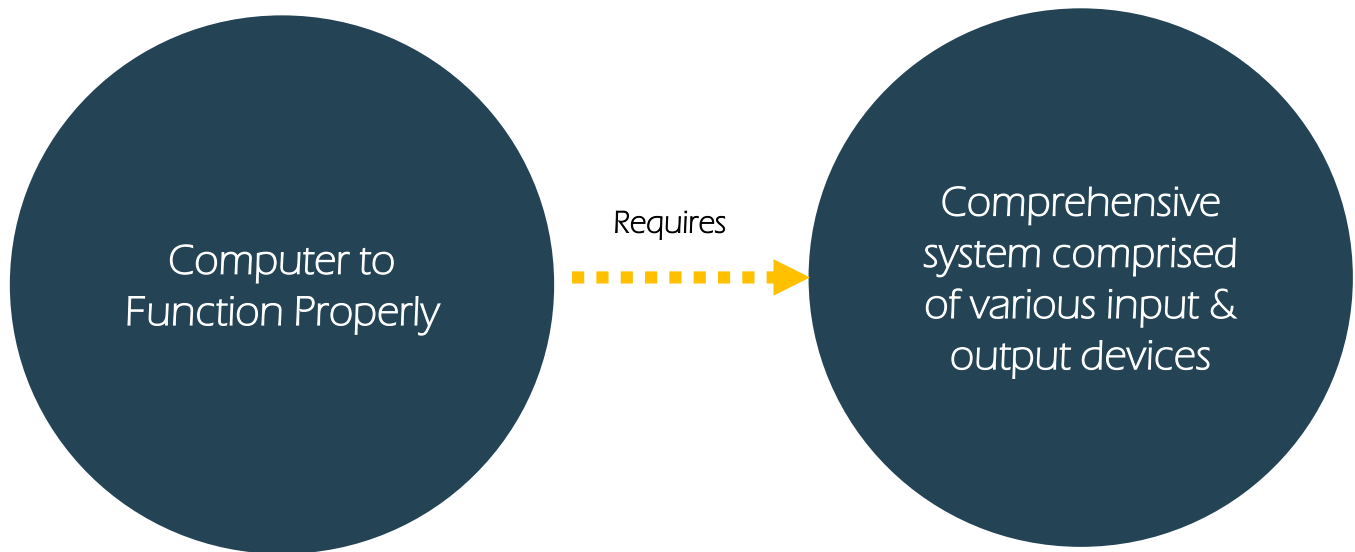

TYPES OF SENSORS

1

OXYGEN SENSOR

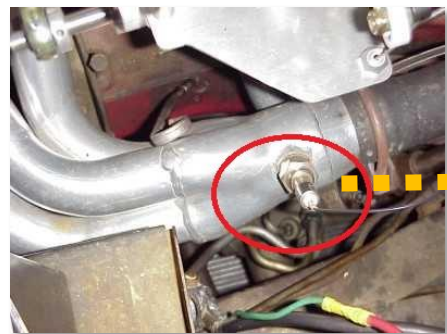

2

AIR INTAKE TEMPERATURE SENSOR



3

CRANK ANGLE SENSOR

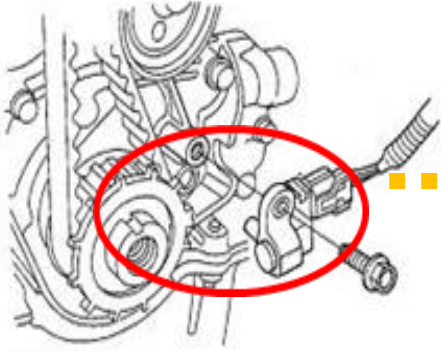

4

ENGINE TEMPERATURE SENSOR

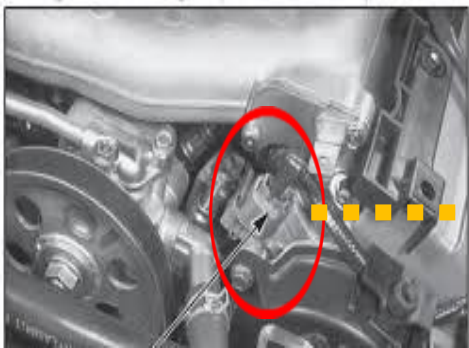

5

MANIFOLD PRESSURE SENSOR

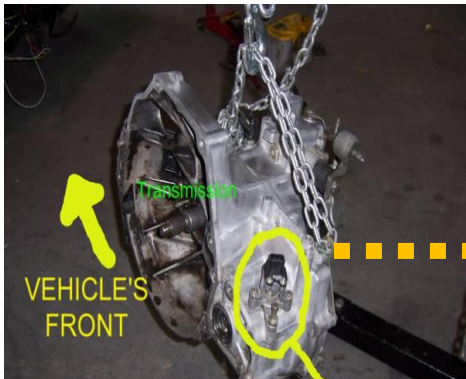

6

KNOCK SENSOR



7

ENGINE SPEED SENSOR

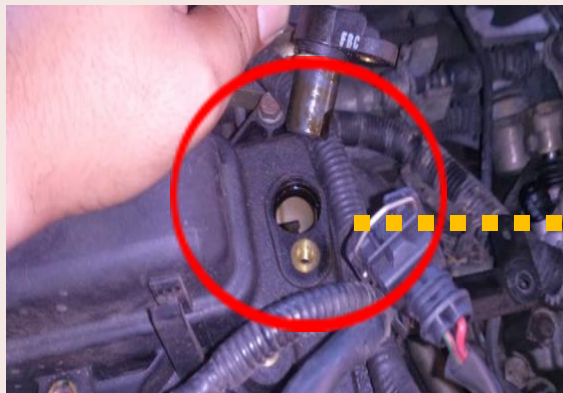

8

AIR FLOW SENSOR



9

THROTTLE POSITION SENSOR



10

ENGINE OIL SENSOR

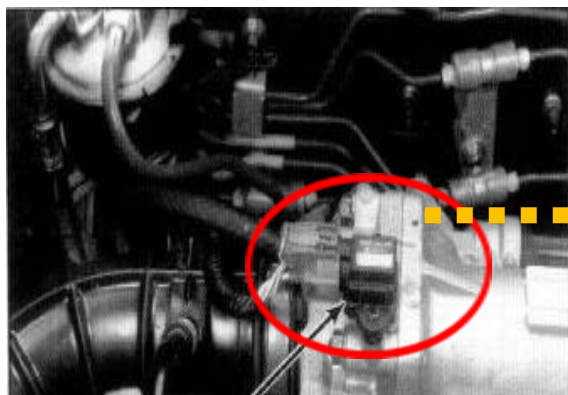

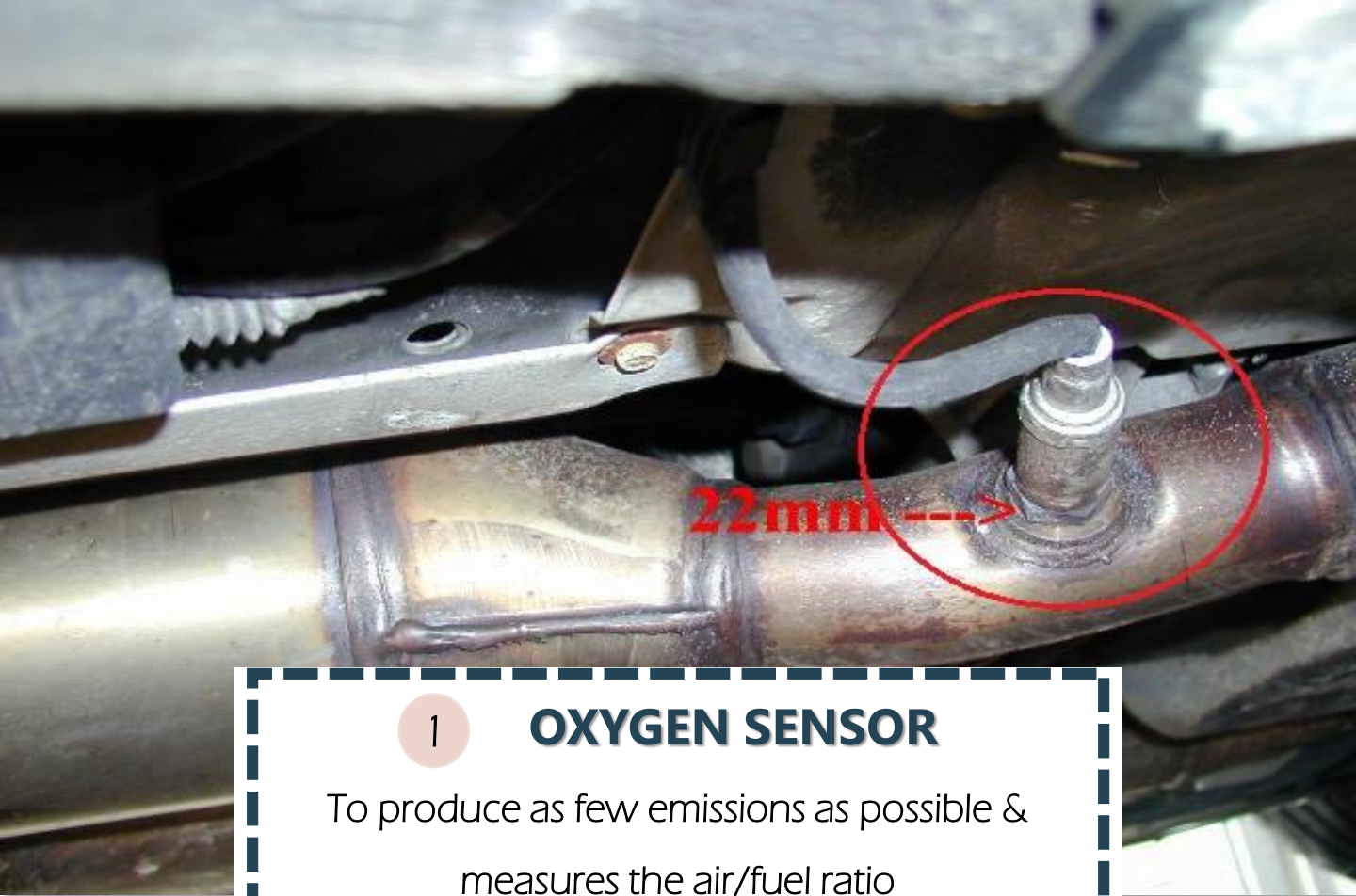

1

OXYGEN SENSOR

To produce as few emissions as possible & measures the air/fuel ratio

- The Oxygen Sensor measures the amount of oxygen in the exhaust gas and delivers a signal to the engine management unit, which changes the air-fuel mixture to the proper level.
- A lean mixture implies too much oxygen in the exhaust gas, which can result in performance issues such as misfires.
- A rich combination with too little oxygen loses gasoline and produces excessive exhaust fumes.

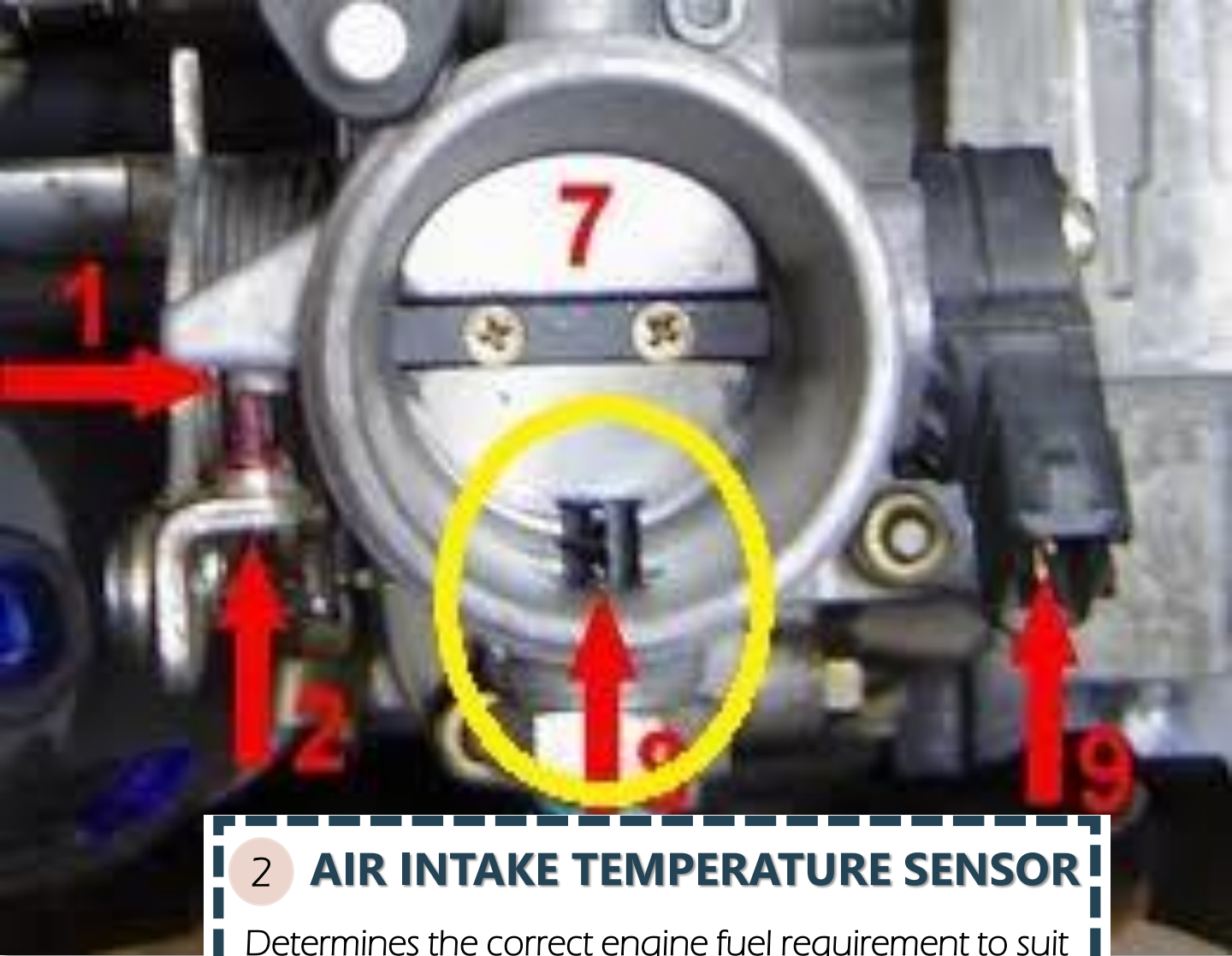

2 AIR INTAKE TEMPERATURE SENSOR

Determines the correct engine fuel requirement to suit the operating air

- The air intake tract has this sensor. Its signal is used in conjunction with the signal from the manifold absolute pressure sensor to calculate the intake air mass.
- Aside from that, the desired values for the various control loops can be adjusted according to the ambient temperature.

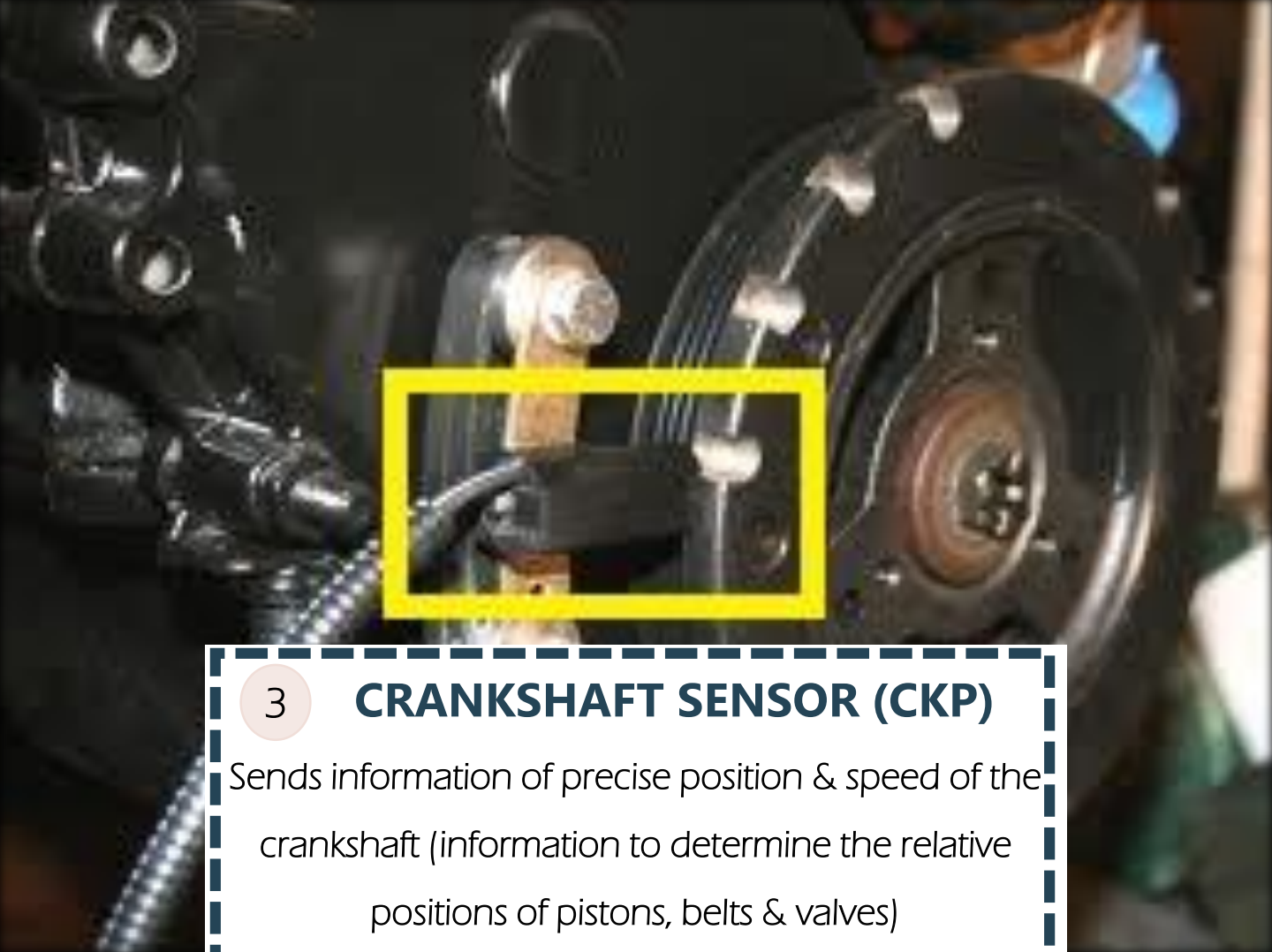

3 **CRANKSHAFT SENSOR (CKP)**

Sends information of precise position & speed of the crankshaft (information to determine the relative positions of pistons, belts & valves)

- The crankshaft position sensor's primary function is to determine the crank's position and/or rotational speed (RPM).
- The crank sensor can be used in conjunction with a cam shaft position sensor to monitor the engine's piston-valve relationship, which is especially significant in engines with variable valve timing.





5

MANIFOLD PRESSURE SENSOR (MAP)

The pressure in the intake manifold is compared to the atmospheric pressure.

- The engine's electronic control unit receives instantaneous manifold pressure information from the manifold absolute pressure (MAP) sensor (ECU).
- The data is used to calculate air density and determine the air mass flow rate of the engine, which determines the fuel metering needed for optimal combustion.



6

KNOCK SENSOR

Engine knock or detonation is detected, and the timing of the engine is controlled as a result. - caused when a spark plug does not ignite the fuel properly

- Knock sensors are vibration sensors that can be used to detect acoustic oscillations caused by structures.
- When uncontrolled ignition occurs in a vehicle's engine, for example, these appear as a "knock," which the sensor converts into electrical impulses and sends to the ECU.

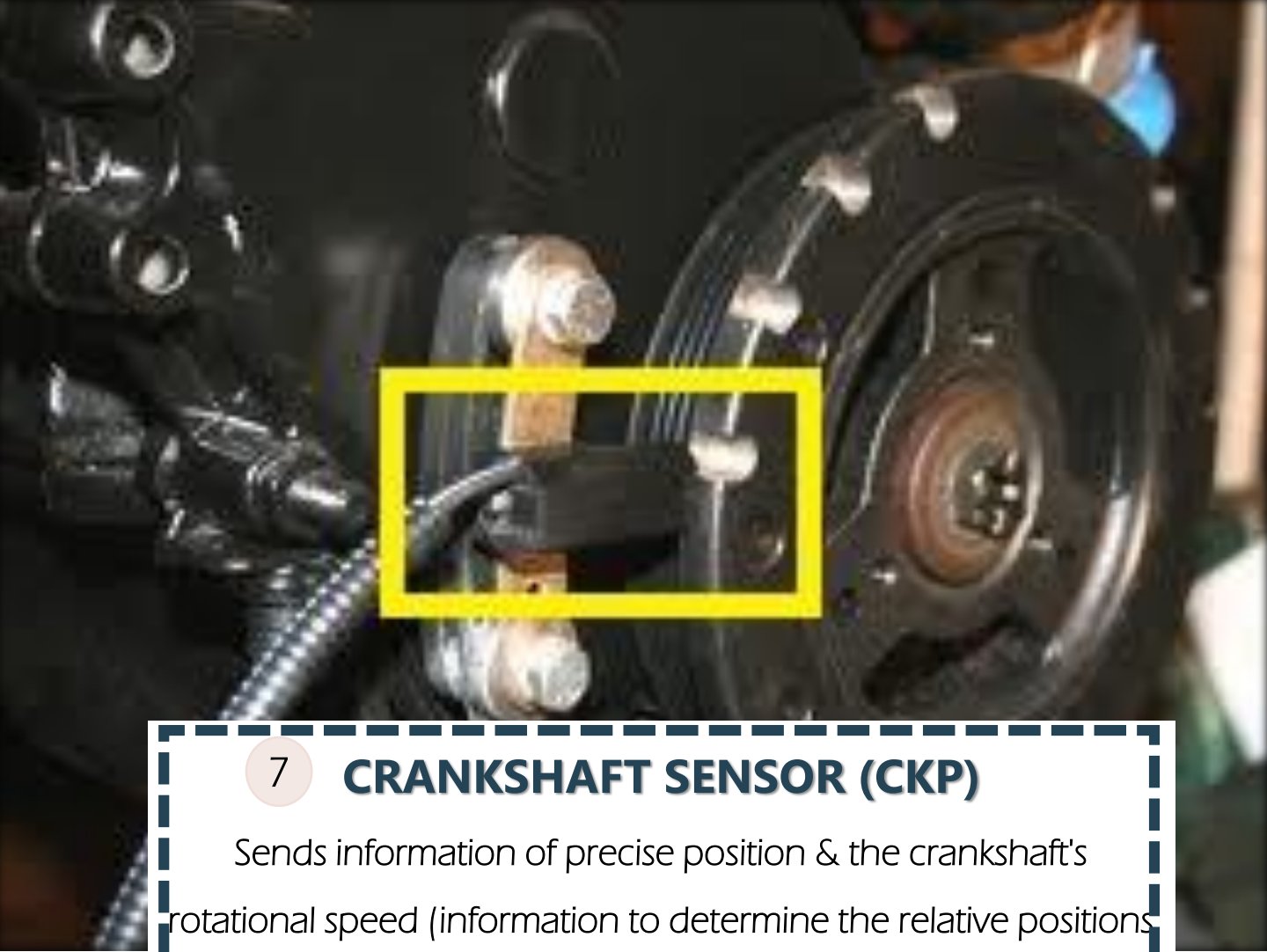

7

CRANKSHAFT SENSOR (CKP)

Sends information of precise position & the crankshaft's rotational speed (information to determine the relative positions of pistons, belts & valves)

- The crankshaft position sensor's primary function is to determine the crank's position and/or rotational speed (RPM).
- The crank sensor can be used in conjunction with a cam shaft position sensor to monitor the engine's piston-valve relationship, which is especially significant in engines with variable valve timing.

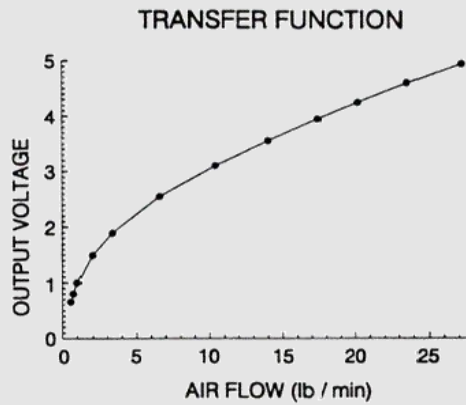
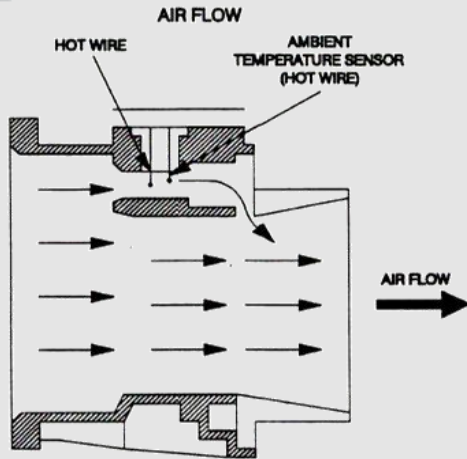

8 MASS AIR FLOW SENSOR (MAF)

Engine load is used to determine how much air an engine takes in.

- The mass flowrate of air entering a fuel-injected internal combustion engine is measured using a mass air flow sensor.
- The engine control unit (ECU) needs the air mass information to balance and deliver the correct fuel mass to the engine.
- On automobile engines, there are two types of mass airflow sensors in use. The vane metre and the hot wire are these.



9 THROTTLE POSITION SENSOR

To inform the computer of the throttle's position and to assist the computer in determining whether the throttle is closed or open, as well as how quickly the throttle opened or closed.

- In an internal combustion engine, a throttle position sensor (TPS) is a sensor that monitors the position of the throttle..
- The sensor is commonly mounted on the butterfly spindle to monitor the throttle valve butterfly's position directly.



10

ENGINE OIL SENSOR

To measure engine oil temperature by providing a resistance signal proportional to the oil temperature

- The coolant circuit contains this sensor.
- When calculating the engine temperature, the engine management system uses its signal.

COOLANT SENSOR

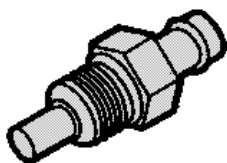

Coolant sensor voltage drop as engine warms up

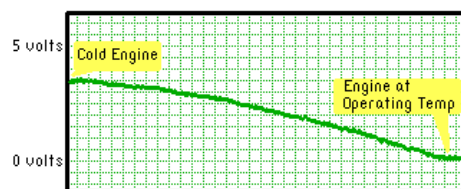

Low temperature = High resistance & voltage

High temperature = Low resistance & voltage

AA1Car.com

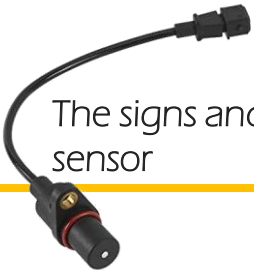

The signs and symptoms of a malfunctioning or broken crankshaft position sensor

1. Problems in starting the vehicle

The crankshaft position sensor keeps track of the crankshaft's position and speed, as well as other information that are vital when starting the engine. The car may have intermittent starting troubles or not start at all if the crankshaft position sensor is malfunctioning.

2. Stalling occurs on a regular basis.

If there is a problem with the crankshaft position sensor or its wiring, the crankshaft signal can be cut off while the engine is operating, causing the engine to stall.

3. The Check Engine Light illuminates.

An illuminated Check Engine Light is another sign of a possible problem with the crankshaft position sensor. If the computer identifies a problem with the signal from the crankshaft position sensor, the Check Engine Light will illuminate to inform the driver. A Check Engine Light can be caused by a number of different problems, therefore getting your computer inspected for fault codes is strongly recommended.

CRANKSHAFT POSITION SENSOR failing / bad



TYPES OF ACTUATOR

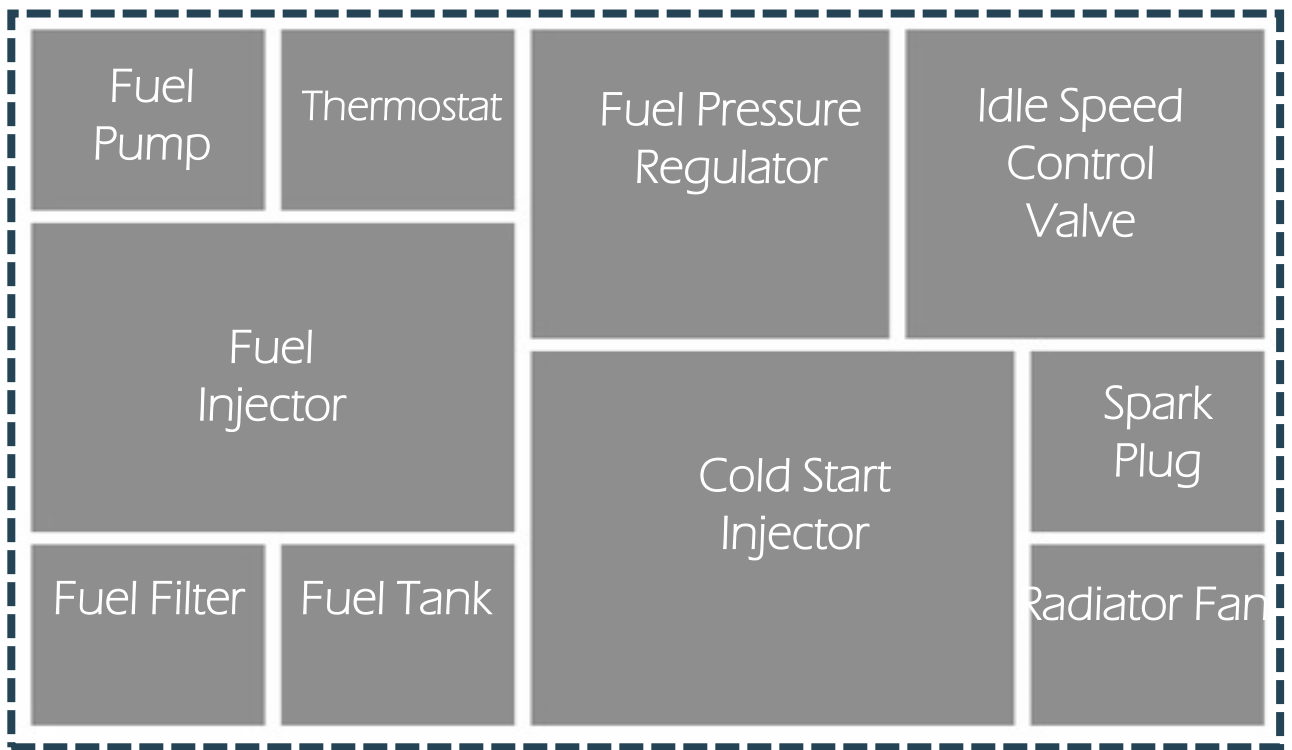

SPARK PLUG

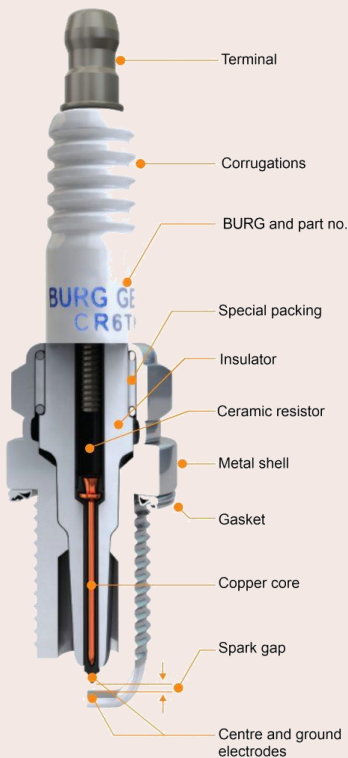

At the top of the plug is a copper centre electrode core surrounded by a nickel alloy. The centre electrode of the plug is enclosed in porcelain, which aids in the passage of heat from the engine to the cooling system. Precious metals, such as platinum or iridium, are used instead of nickel alloy in premium spark plugs. The air and fuel combination inside the combustion chamber is ignited by the spark plug.

Slow acceleration, loss of power, poor fuel economy, engine misfires, and difficulties starting the automobile are all indicators of damaged spark plugs.



FUEL INJECTORS

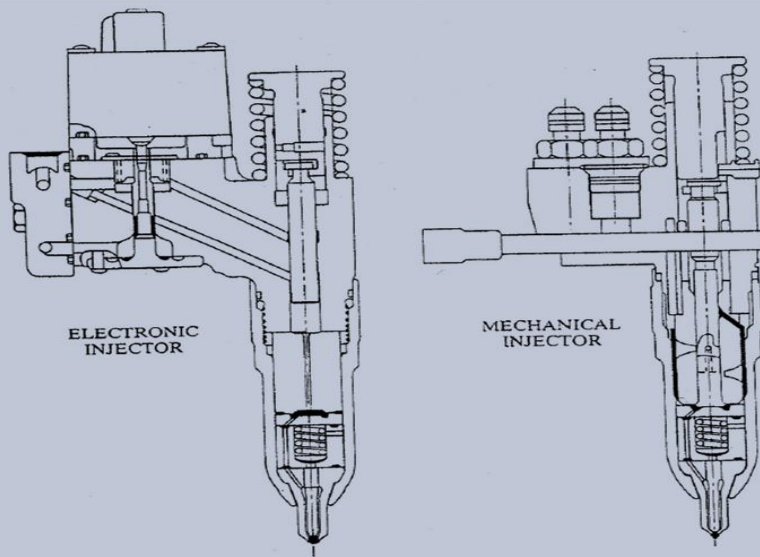

PETROL INJECTOR

- Fuel pressure in a gasoline engine is normally between 35 and 50 psi.
- The injector feeds fuel through the spray tip and into either the intake manifold, slightly upstream of the intake valve, or straight into the cylinder as the plunger rises.

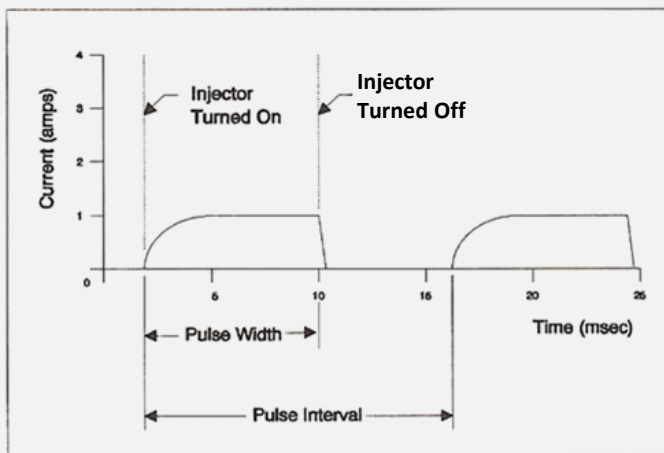
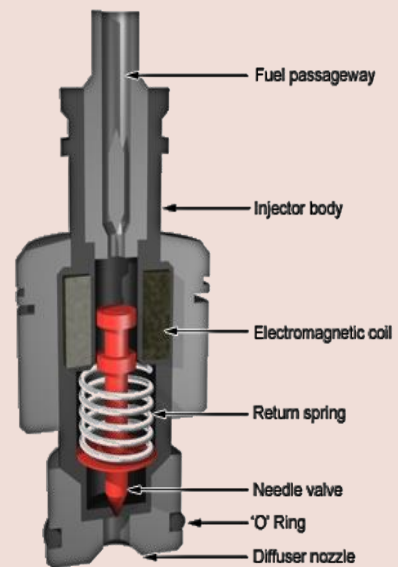

COMPRESSION RATIOS

Fuel pressure and injector pulse width time influence the amount of fuel injected.

Typical pulse width is 1 – 10 ms at full load.

Primary factors are load and engine temperature.

Injector design and fuel additives help reduce injector tip deposits and clogging.

MAIN COMPONENTS

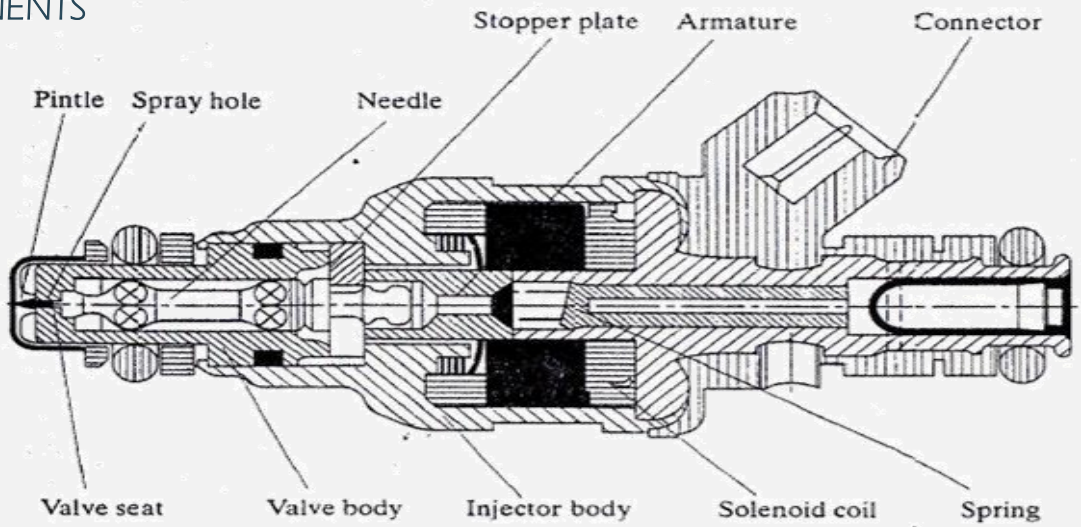

PINTLE



MULTI-HOLE



PORT INJECTION

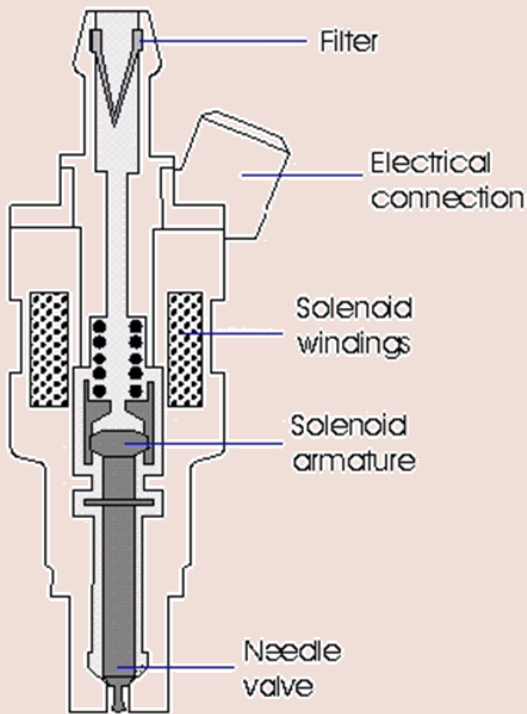
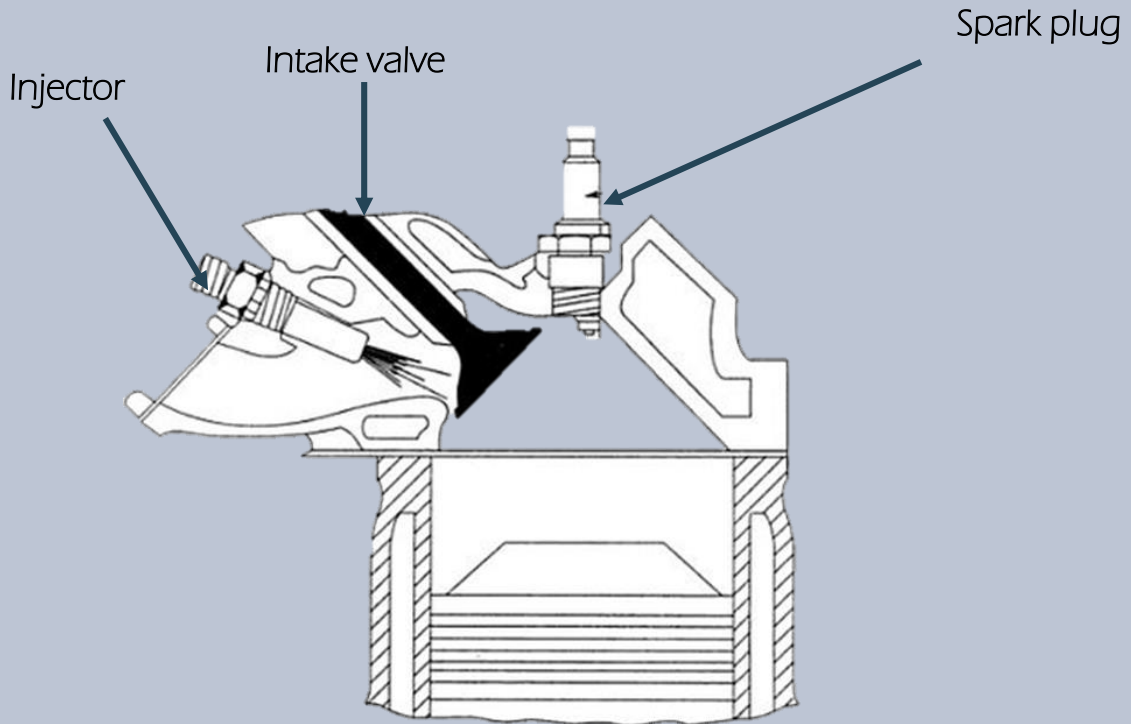

FUNCTION OF FUEL INJECTOR

- Gasoline nozzles that spray fuel into the intake air
- Fuel is shot into the air when the nozzle is opened.
- Injector pressure and injection time length govern the amount of fuel injected per cycle.

FUEL TANK

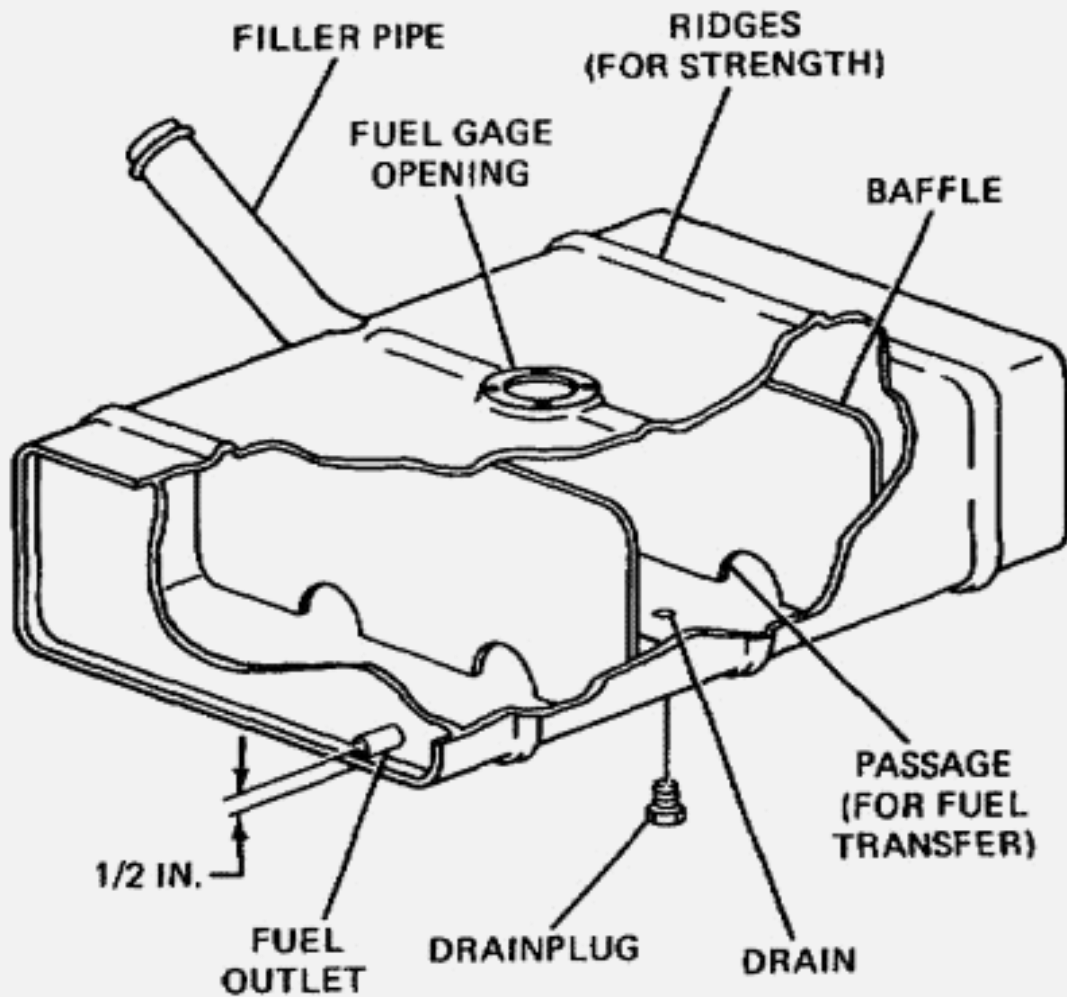

- Fuel tanks: Hold 45-75 litres
 - Plastic or corrosion-resistant galvanised steel
 - The baffle keeps the fuel from splashing around in the tank.
 - The pickup tube, fuel gauge, and fuel pump are all part of the cluster assembly.
 - At the end of the pickup tube is an in-tank filter.

FUEL PUMP

- Between the engine and the fuel tank, fuel from the pump is carried by a fuel rail loop.
 - The system's pressure is controlled by the pressure regulator.
- The pressure in the electric fuel pump is maintained when the engine is turned off thanks to a one-way check valve.
 - Because it's submerged in a well of gasoline, it can't spark.
- Electrical circuit for the fuel pump
 - Modern automobiles have computer-controlled electric fuel pumps.
 - It stays on when the motor is rewinding or running.

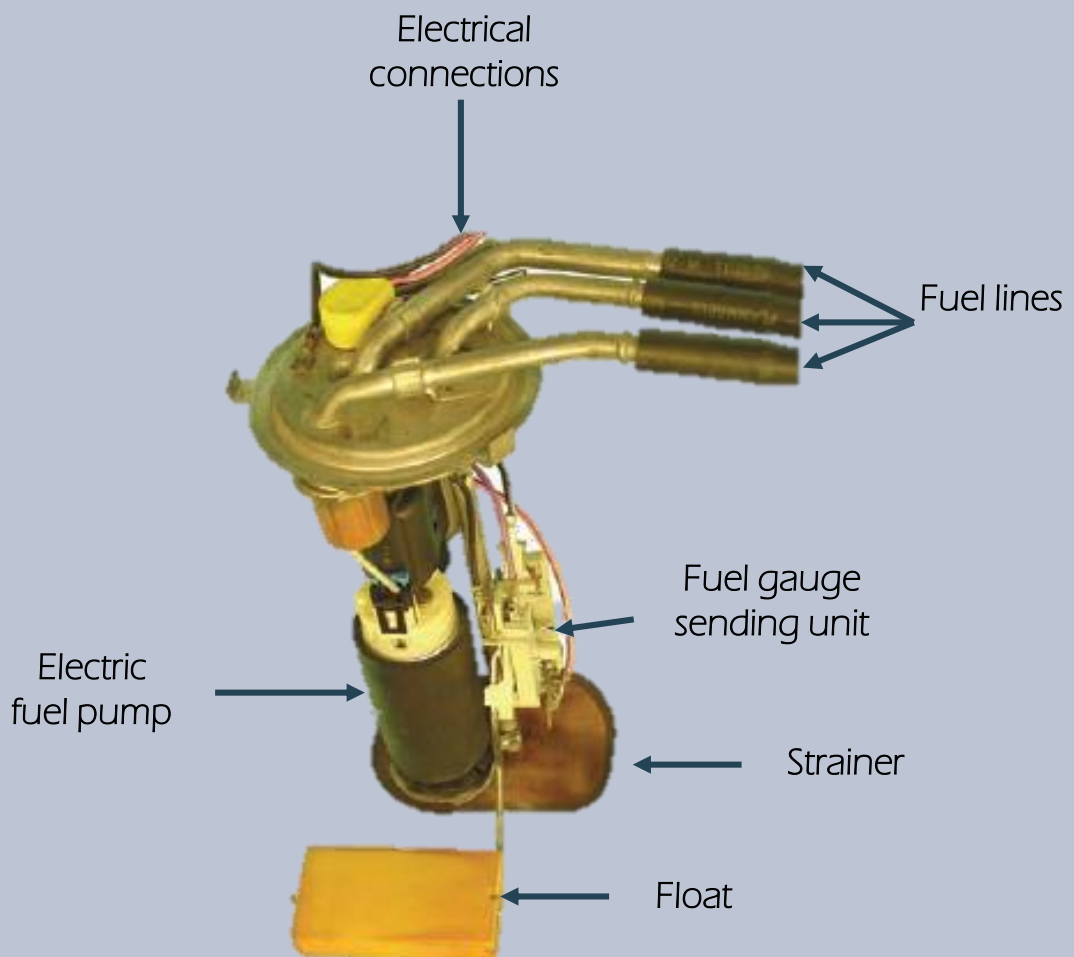

Electric Fuel Pump And Sending Unit in One

FUEL FILTER

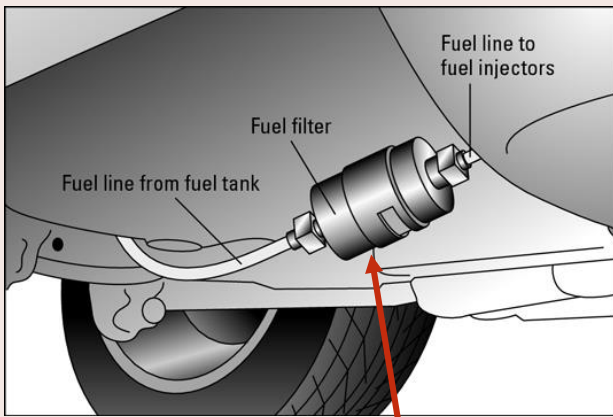

- It might be found in a fuel line or a tank.
 - Filters are positioned on the gasoline pump's outlet side.
- Fuel injection systems
 - Large, heavy-duty filters are required.
 - Allow the pump to provide fuel while filtering out small dirt particles.

FUEL PRESSURE REGULATOR

- It's at the end of the gasoline rail.
- Consistent injector pressure is maintained.
- A diaphragm is located within the internal chamber
 - *On one side, pressurised fuel; on the other, unpressurized fuel*
 - *On one hand, there's vacuum in the manifold, and on the other, there's spring tension.*
- The fuel is measured back into the tank when the manifold vacuum draws up on the diaphragm.
- Fuel pressure that is too high can overcome spring tension and enable fuel to flow back into the tank.
- Spring tension forces the diaphragm down when manifold pressure rises, blocking the return line and increasing rail pressure.

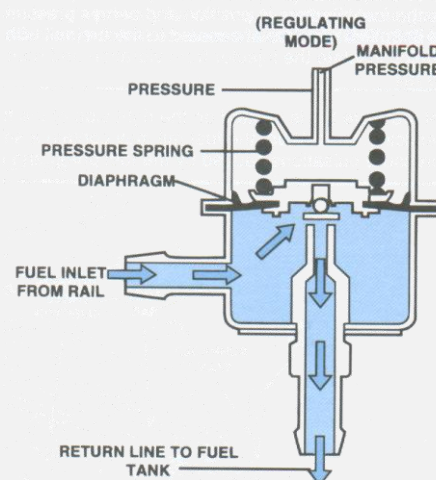
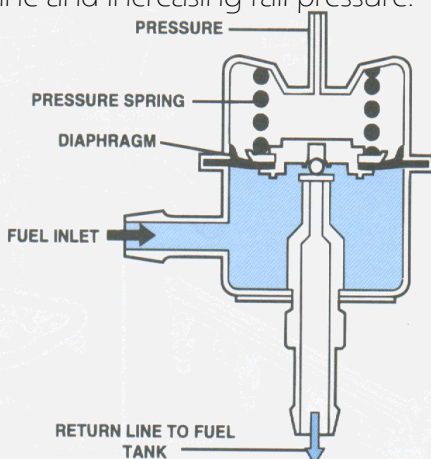

THERMOSTAT

- A thermostat regulates the temperature of water or coolant in an engine.
- When the engine is cold, coolant does not flow through it..
- It helps the engine reach its ideal operating temperature, increasing efficiency and lowering pollutants.
- When the engine reaches operating temperature (about 200 degrees Fahrenheit, 95 degrees Celsius), the thermostat opens, allowing the radiator to take heat from the coolant and circulate it back into the engine.

typical thermostat parts

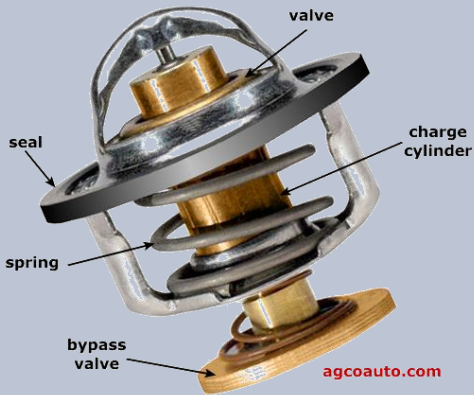

- When a thermostat fails, it can either stick closed, causing the engine to overheat quickly, or it can stick open, causing the engine to warm up too slowly, resulting in the check engine light to illuminate.

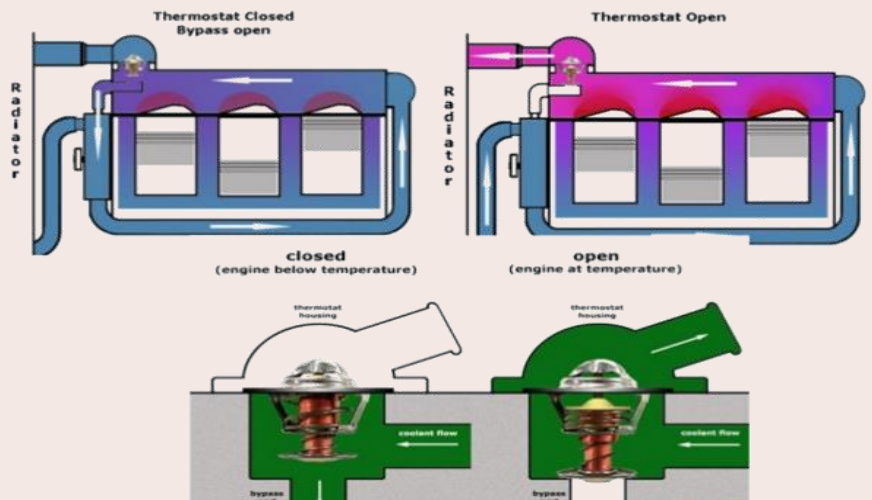
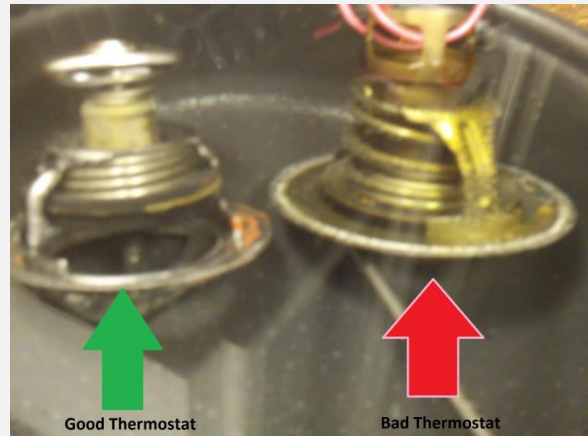

Thermostat Operation

IDLE SPEED CONTROL VALVE (ISCV)

- In fuel-injected vehicles, an idle air control actuator or idle air control valve (IAC actuator/valve) controls the engine's idling RPM.
- In carbureted autos, a similar mechanism known as an idle speed control actuator is used.

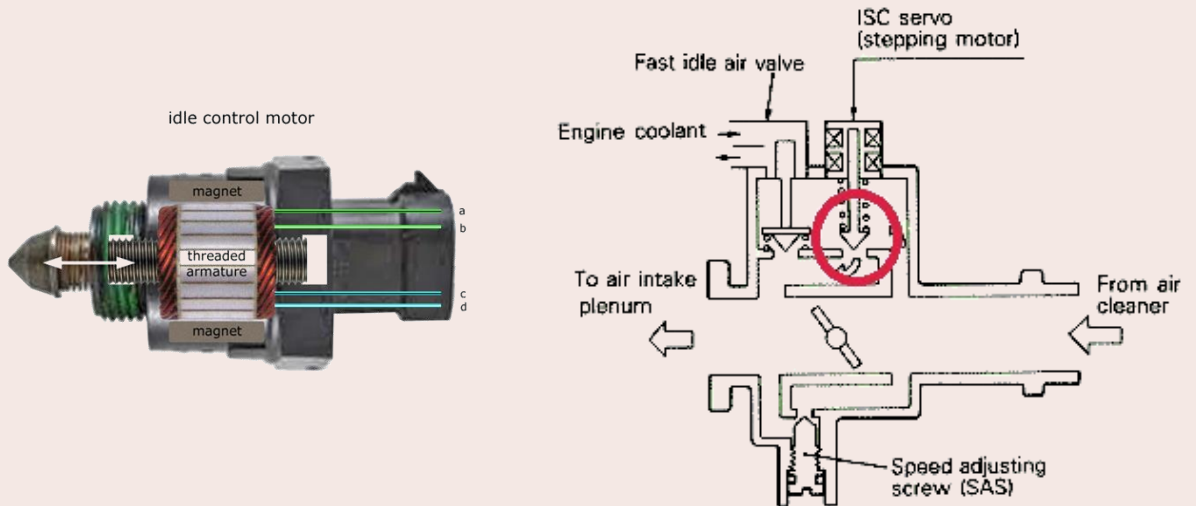

RADIATOR FAN

A cooling fan is a vital component in a car's cooling system, that helps to take away all heat absorbed from the engine using a coolant. By pushing or pulling air through the radiator, it accomplishes all of its tasks. A radiator cooling fan is located in front of a car and it's electrically powered, well, depending on the vehicle's design.





SIGNS OF FAILURE IN SPARK PLUGS

1. Acceleration is slow.
2. Poor fuel economy.
3. Engine is misfiring.
4. Engine surging or hesitating.
5. Rough idle.
6. Hard to start.



DIRTY FUEL INJECTOR SYMPTOMS

1. The engine misfires. Your vehicle's engine may misfire due to dirty fuel injectors.
2. Idling gets rough. When you're stopped at a stop sign or stuck in traffic, does your car splutter and shake?
3. Your gas mileage has dropped dramatically.
4. The RPM needle begins to spin.
5. Your vehicle will not start.

TYPES OF FUEL INJECTION SYSTEM

FUEL INJECTION SYSTEM

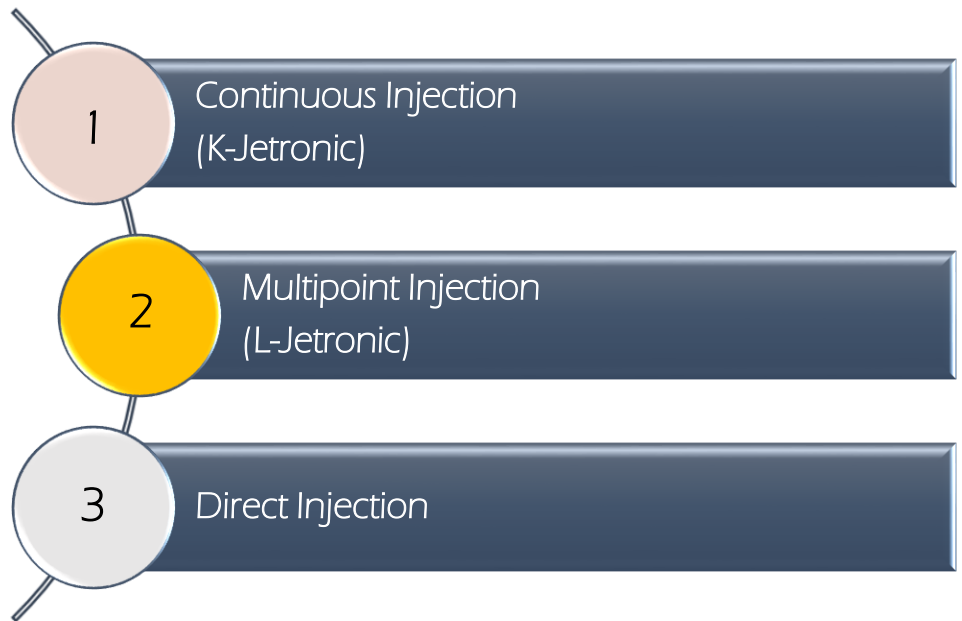

Continuous Injection (K-Jetronic)

Component

- ✓ - Fuel Tank
- ✓ - Fuel Filter
- ✓ - Fuel Pump
- ✓ - Accumulator – maintains rest pressure & reduced noise created by pulsation of pressure
- ✓ - Air Flow Sensor

Function

- Mechanical-hydraulic and continuous fuel injection
- Per cylinder, one injector-valve through its own controller connected to fuel regulator
- Sprays fuel through the injectors continuously.
- Sprays at minimal rate to provide only what is needed for each cylinder to have the proper air-fuel ratio

Multipoint Injection (L-Jetronic)

Components

- - Fuel Delivery System
- - Electric Fuel Pump
- - Fuel Filter
- - Fuel Pressure Regulator
- - Fuel Injectors
- - Cold Start Injector
- - Fuel Accumulator
- - Connecting Lines & Hoses

Function

- One injector per cylinder is used in multi-point systems (system indirect injection)
- The quantity of charge between cylinders is frequently controlled, usually cycle by cycle.
- The opening and closing of injection valves is controlled by engine sensors and the computer
- Fuel is injected into the intake manifold ports on a regular basis.

Direct Injection

•Features

- - Allows for extremely lean air/fuel mixes to be used.
- - Volumetric efficiency is improved.
- - Extremely high fuel pressures are used (typically between 400 and 2000 psi)
- - The system works in the same way as diesel injection systems.



TYPICAL GDI SYSTEM

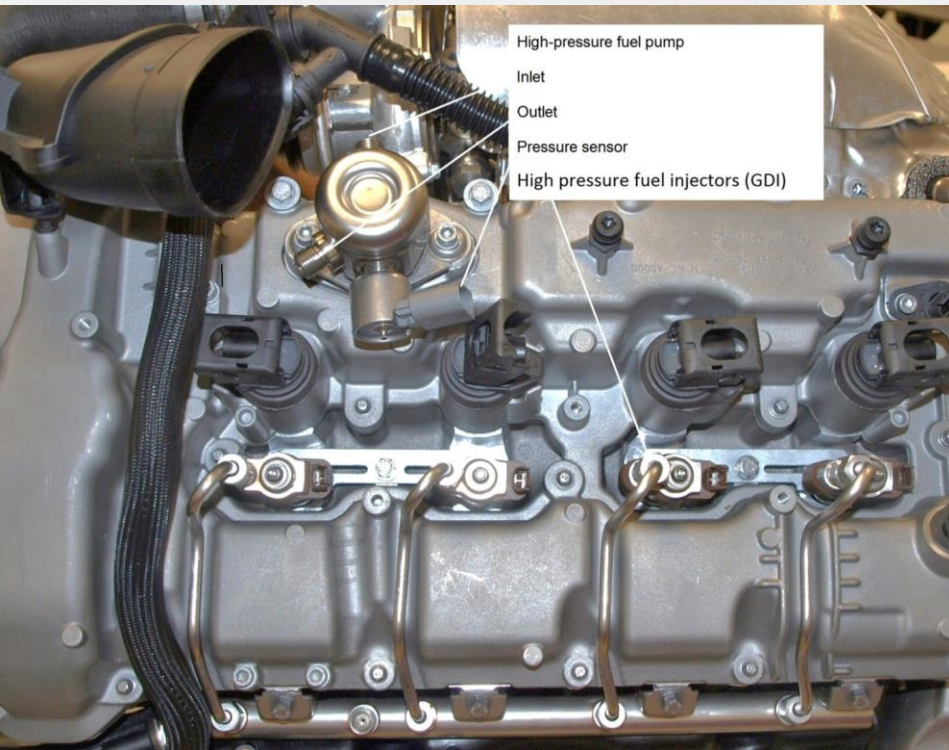

OPERATIONAL MODES

- Lean Burn
 - It's possible to reach a 60:1 ratio
- Stoichiometric
 - During a moderate load
- Full Power
 - During the application of strong weights and rapid acceleration

HIGH PRESSURE FUEL PUMP

- Gas is delivered to the engine using an in-tank pump.
- A high-pressure mechanical pump raises fuel pressure to 435 to 1885 psi.
- Fuel rail pressure sensor input regulates pressure.



COMPRESSION RATIOS

- Because of the flexibility to modify air/fuel ratios, spark knock is minimised allowing for higher compression ratios
- It is not required to use a fuel with a higher octane rating.
- Smaller fuel droplets keep the cylinder cold.
- The mixture burns more quickly..
- There isn't as much of a need for spark progression as there formerly was.

Stratified mode

Homogeneous mode



ADVANTAGES OF GDI

- Increased fuel economy
- High-capacity output
- Increases the volumetric efficiency of the engine
- Engine thermal loss is reduced
- Reduces emissions
- Allows higher compression
- Reduces most turbo lag when turbocharged

Direct fuel injection is more expensive than indirect fuel injection.

If the injectors are exposed to increased heat and pressure, more expensive materials and higher-precision electronic management systems are required.

- Rail System

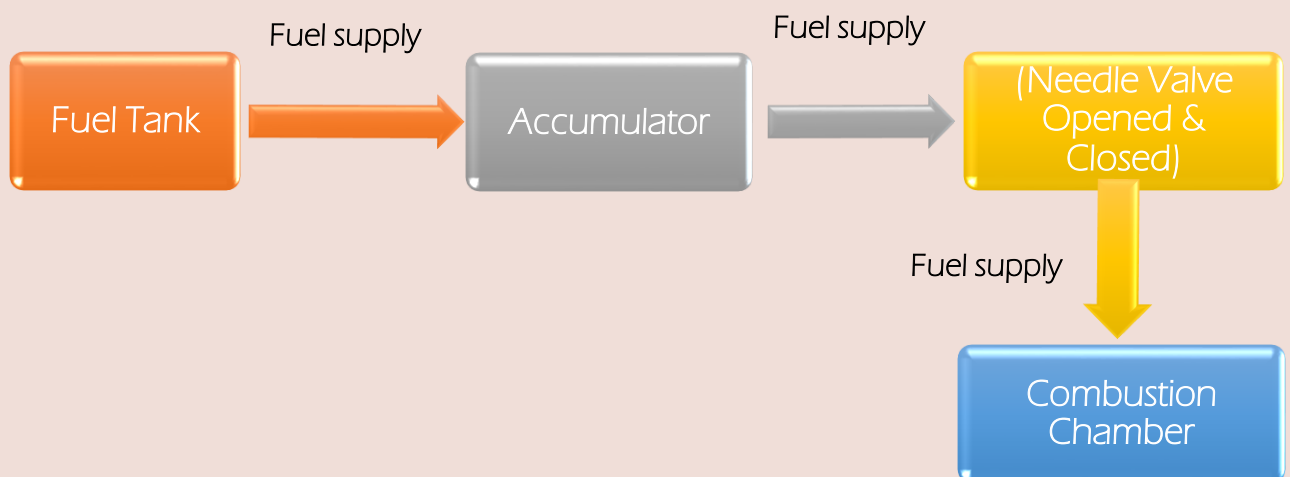

DIFFERENCE

K- JETRONICS CONTINUOUS INJECTION SYSTEM (CIS)

A continuous stream of fuel is injected.

The volume flow rate is mostly mechanically controlled to match engine demand

More fuel efficient oriented

L – JETRONICS ELECTRONIC FUEL INJECTION (EFI)

Fuel is injected in pulses.

The pulses' duration and frequency are totally regulated via electrical means

Better throttle response

QUESTION CHAPTER 1

1. State the function of EMS

In charge of adjusting the ignition timing and regulating the amount of fuel injected. The perfect operation of the EMS ensures maximum engine power while emitting the least amount of exhaust and consuming the least amount of gasoline.

2. Please state the meaning of Sensor, Actuator and Electronic Control Unit (ECU).

SENSOR:-

- An electronic device that detects any variation of engine and sends the data to ECU in SIGNAL MODE.

ECU:-

- A complex electronic device that receives data from SENSOR, makes a calculation and converts the data to INSTRUCTIONS MODE and sends to ACTUATOR.

ACTUATOR

- An electronic device that receives an INSTRUCTIONS from ECU to do the directed job.

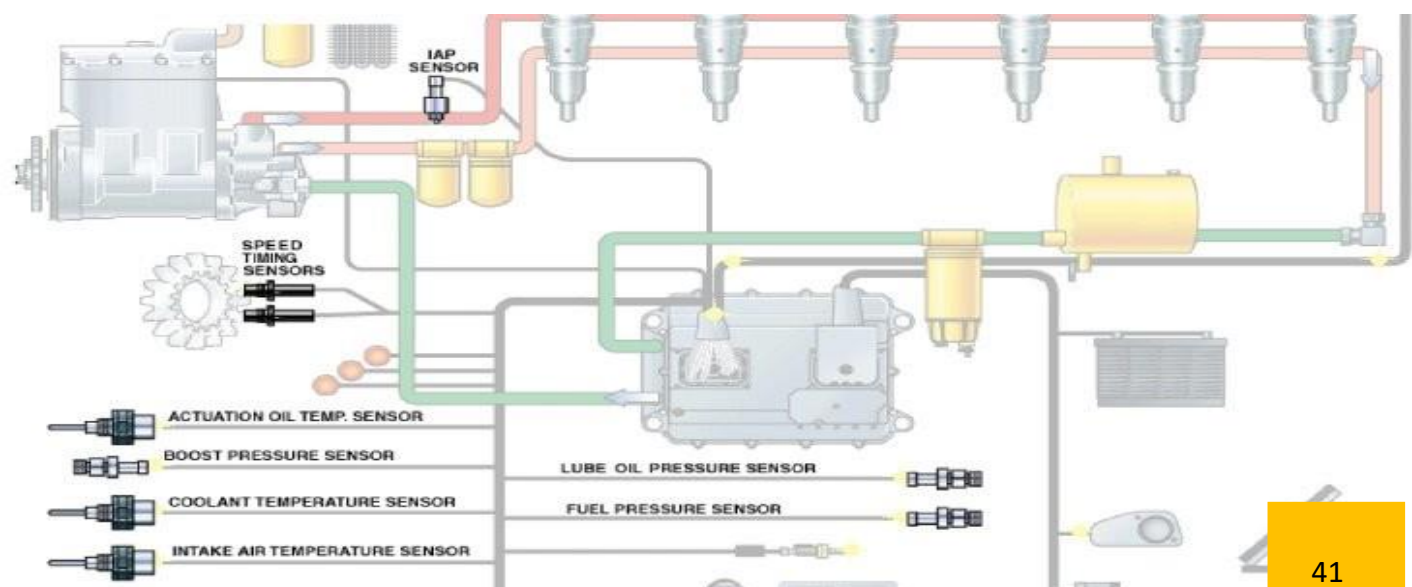

3. Define function of sub-system of engine management system below:

a) Emission Control System

- System that is responsible for the reduction of toxic gases emitted from vehicles

b) Fuel Management System

- The fuel management system is set up to deliver precise amounts of fuel as needed in order to achieve the best balance of power, fuel economy, and low exhaust emissions

c) Control/Sensor System

- System that detects a physical condition and is used to collect/store information to transfer information to ECU

4. Explain briefly the function of the sensors below:

a) Oxygen Sensor

Oxygen sensor: measures the amount of oxygen in the exhaust system of the engine.

b) Manifold Absolute Pressure Sensor

Measures the pressure, or vacuum inside the intake manifold.

c) Throttle Position Sensor





Determines the angle of the throttle.

FUEL THEFT IS WHAT WORRIES YOU ?

ΛESIKAI
Best IoT Solution of the World



BENEFITS OF FUEL MANAGEMENT SYSTEM

-  YOU SUSPECT FUEL PILFERAGE/THEFT
-  YOUR FUEL BILL IS A SURPRISE
-  REAL TIME REPORTING TOOL REQUIRED
-  YOU WANT TO REDUCE MAINTENANCE COST
-  YOU WANT CENTRAL LOCATION MONITORING

5. Please explain the operation of the EFI system with a diagram

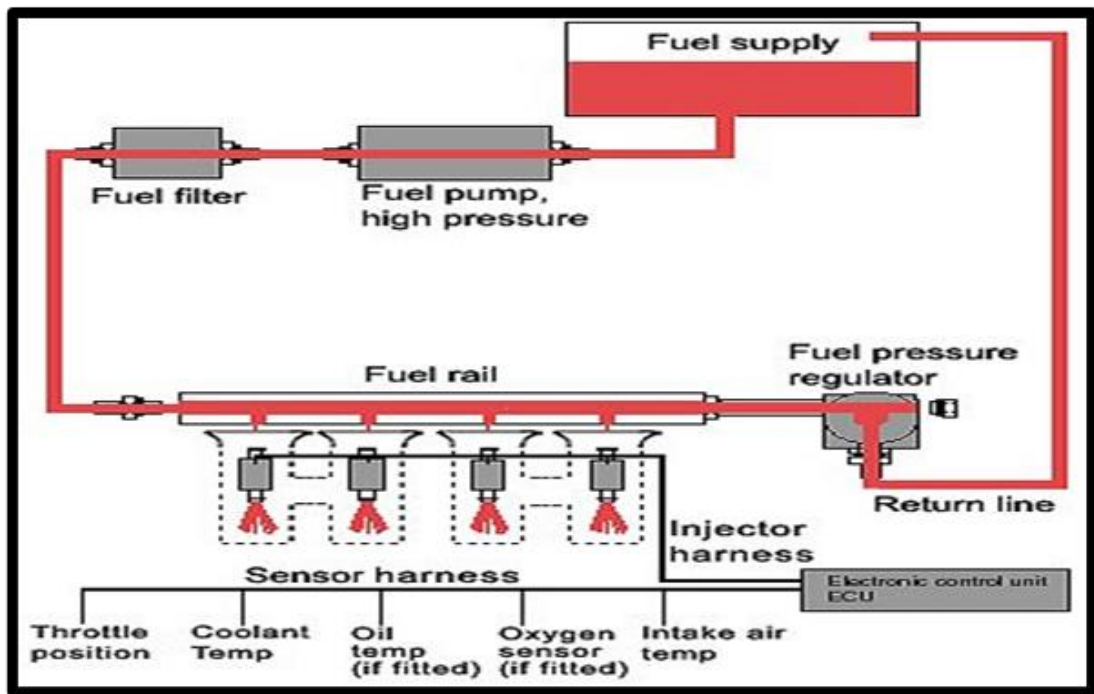

The fuel is transported from the tank to the injector using an electric fuel pump. The gasoline pump is normally located close to or in the fuel tank. An in-line gasoline filter with a large capacity removes impurities.

A fuel pressure regulator ensures that the fuel pressure remains constant. Any fuel not delivered to the intake manifold by the injector is returned to the tank via a fuel return line.

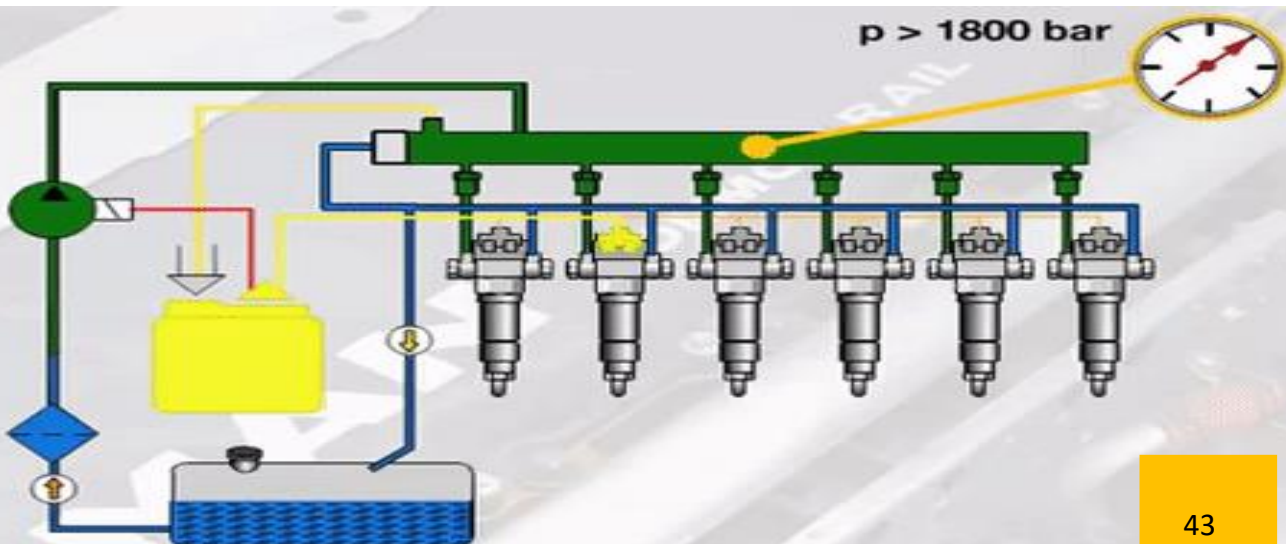

6. Fuel pressure regulator is one component in the EFI system. With the aid of diagrams, explain the operations of fuel pressure regulator.

- i. Located at the far end of the fuel rail
- ii. Maintains consistent injector pressure
- iii. Internal chamber contains a diaphragm
 - Pressurized fuel on one side
 - Manifold vacuum & spring tension on other
- iv. Manifold vacuum pulls up on diaphragm, metering fuel that is returned to tank
- v. Excess fuel pressure can overcome spring tension and allow fuel to flow back into the tank.
- vi. Spring tension pushes the diaphragm down as manifold pressure rises, blocking the return line and increasing pressure in the rail.

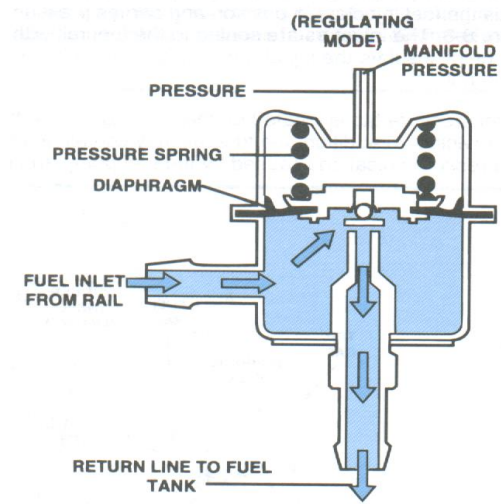
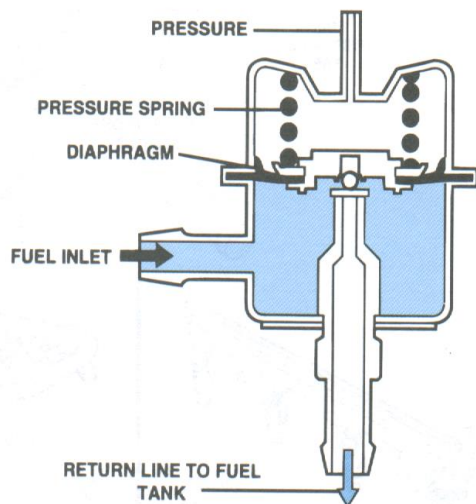

7. Describe the advantages of Electronic Fuel Injection System

- i. Mixture distribution with a uniform the air-to-fuel ratio
- ii. Controlling the air-to-fuel ratio with extreme precision during an engine's operation
- iii. Fuel economy is excellent, and pollutants are controlled well.
- iv. It is now easier to start and operate a cold engine
- v. Superior power and throttle response

8. Explain the distinctions between the THREE (3) fuel injection system types using diagrams.

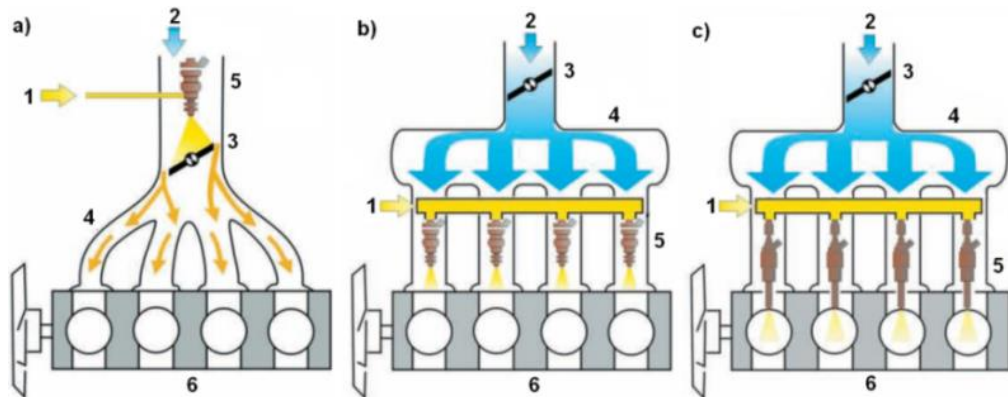

Single Point Injection

Multipoint Injection

Direct Injection

- i. Single Point - Uses only one injector located before TPS, used in earlier version of EFI engine & intake manifold will be full with air and fuel mixture from the throttle body to the intake valve
- i. Multipoint – Uses 4 injectors for each cylinder in manifold, replaces the single point injection used in previous model of EFI engines & intake manifold will only consist of air. Fuel will only be sprayed at the bottom before the intake valve or before the runner in the intake manifold.
- i. Direct – Injector sprays directly into cylinder, latest type of fuel injection system available & intake manifold only consists of air. Fuel will be sprayed in the combustion chamber.

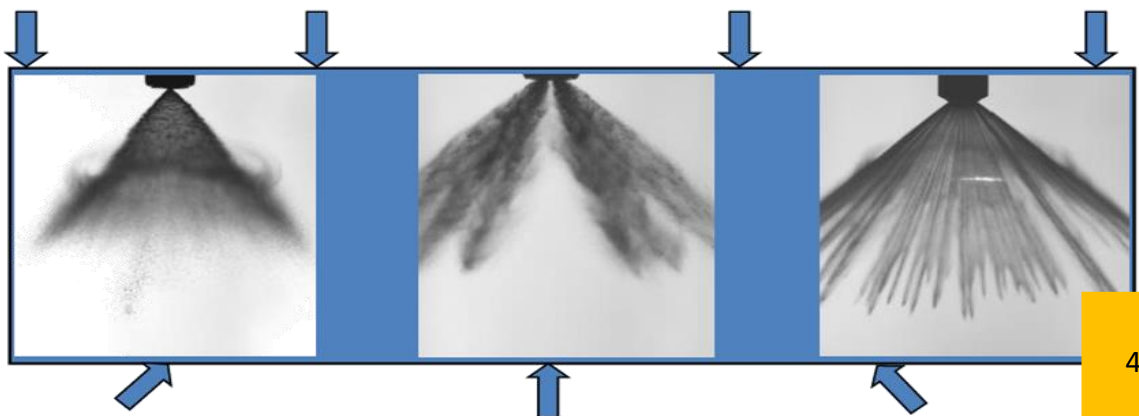

CHAPTER 2



FORCED INDUCTIONS SYSTEM

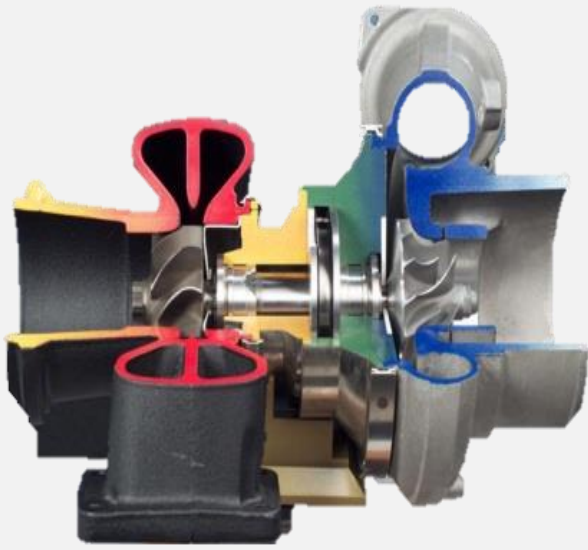

- A method of compressing air at an internal combustion engine's intake by a gas compressor.
- The goal of a forced induction engine is to raise the air pressure, temperature, and density.
- A naturally aspirated engine is one that does not use forced induction.

- In the automotive industry, forced induction is utilised to boost engine power and efficiency.
- However, it is not widely employed since a forced induction system is expensive and difficult, and the engine must be constructed specifically to handle it.



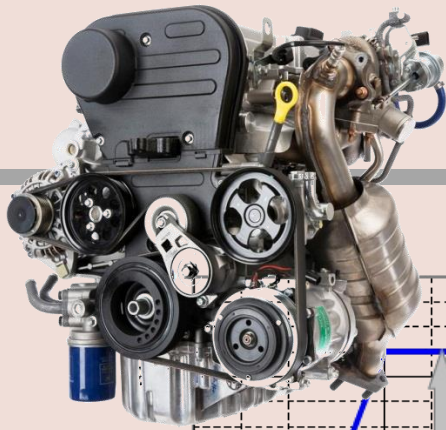

Proton Campro 1.6L CFE

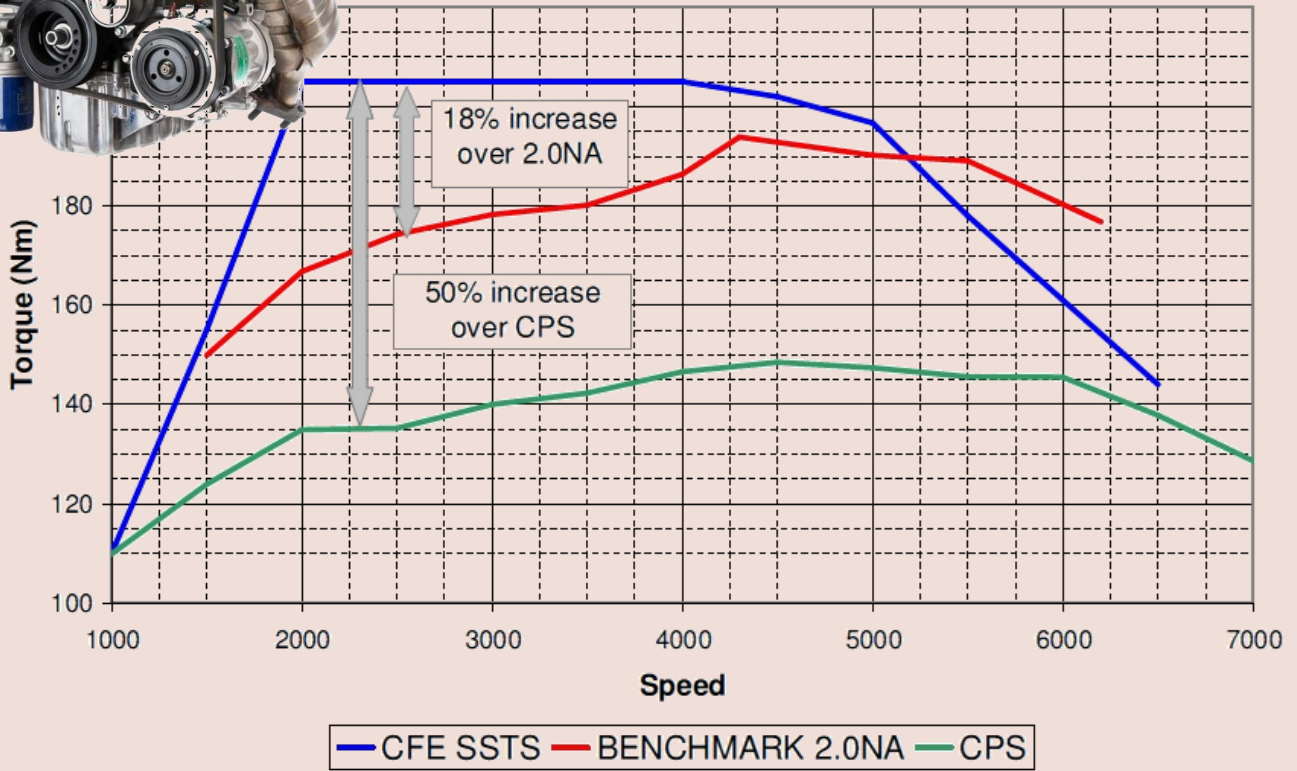

Ford 1.0L Ecoboost

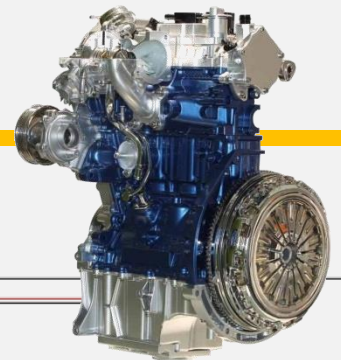

Engine Torque Comparison

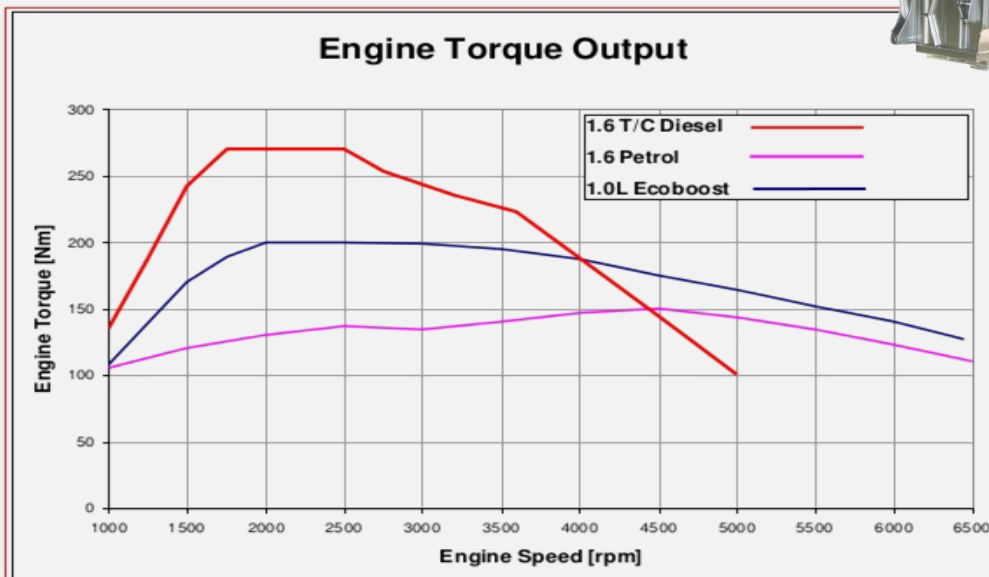

FORCED INDUCTIONS SYSTEM



Turbocharges



Supercharges



TURBOCHARGES

A turbocharger is a centrifugal compressor that is powered by exhaust gas flow.

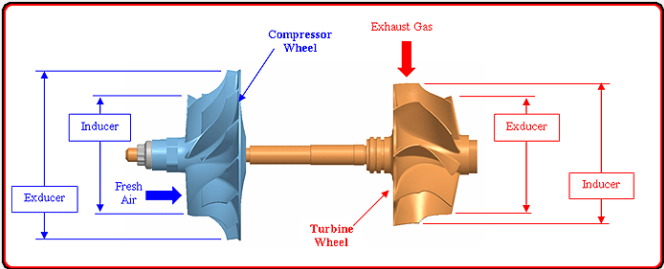

SUPERCHARGES

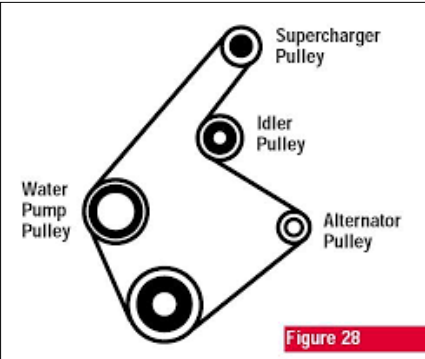
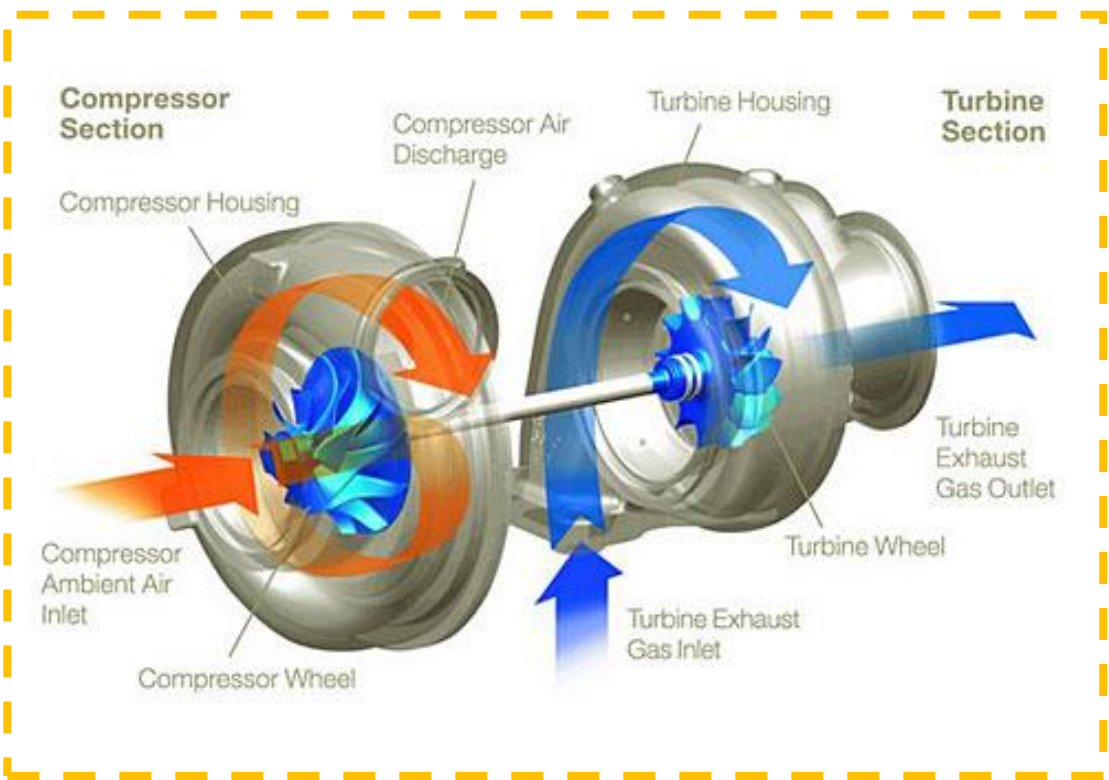

Figure 28

- An air compressor is required for forced induction of an internal combustion engine
- The device can be powered mechanically by a belt, gear, shaft, or chain attached to the engine's crankshaft

TURBOCHARGERS

CONSTRUCTION



INSIDE TURBOCHARGER

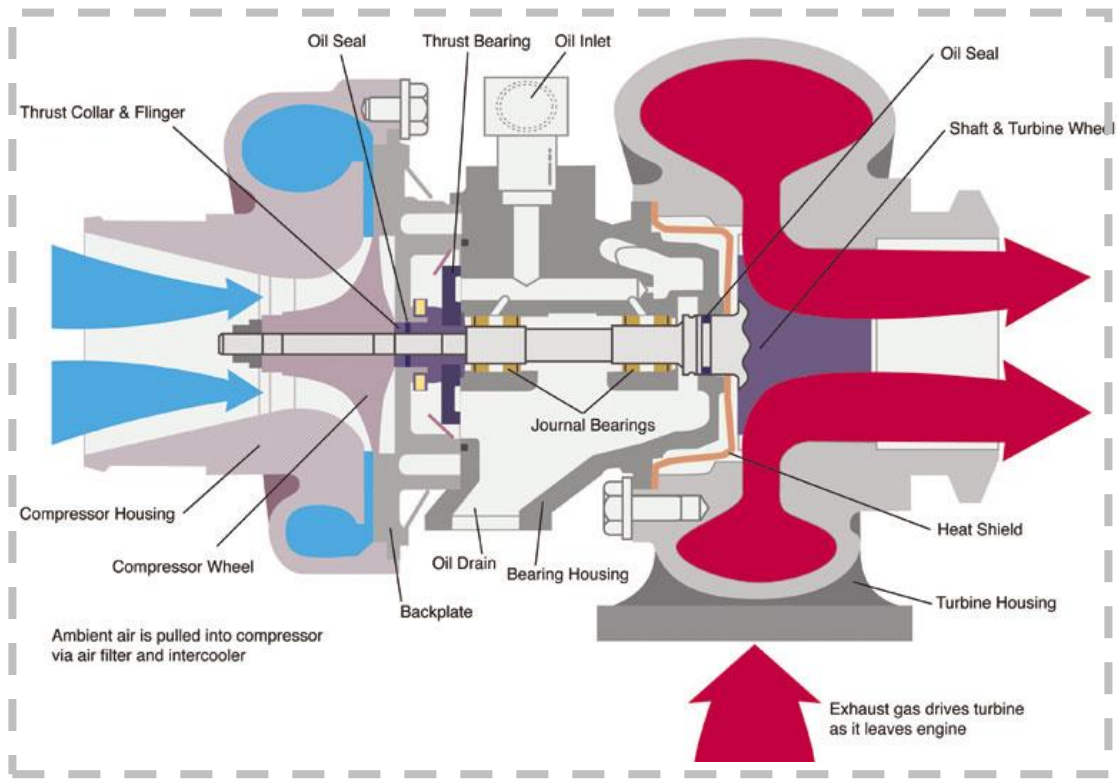

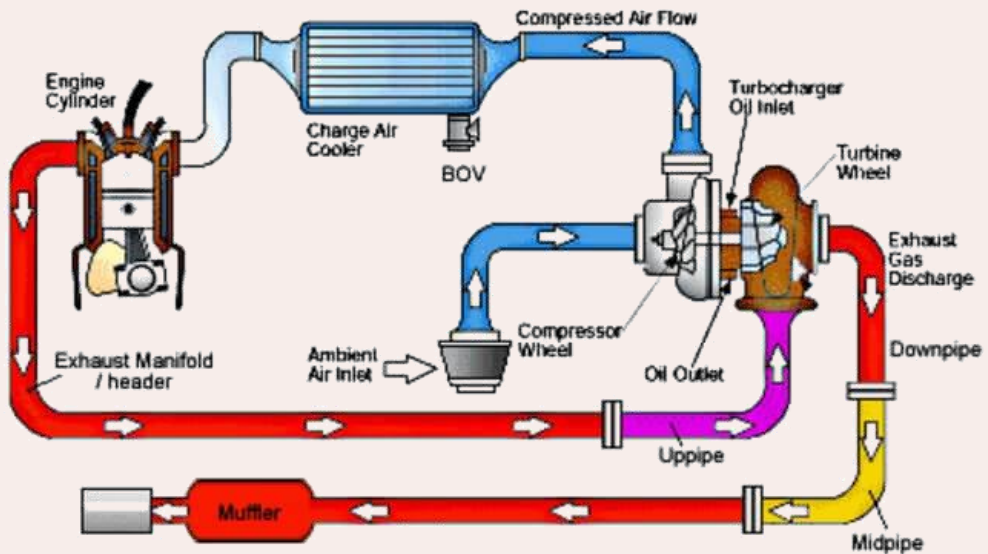

TURBOCHARGER OPERATION

1

Exhaust gases will flow out directly to the **TURBINE WHEEL**, at the same time it makes the turbine wheel to spin a high revolution of **240,000 rev/min**.

2

The **COMPRESSOR WHEEL** is connected to the **TURBINE WHEEL** with a **SHAFT**. In a high revolution, compressor wheel will draw air from outside to compress.

3

This condition causes the air to be heated. This hot air will be directed to the intercooler for cooling.

4

High-pressure cold air to be channeled into the combustion chamber.

5

After the combustion process, exhaust gases will be used to move the turbine wheel before it is discharged through the exhaust muffler.

- The volume and velocity of exhaust gases spin (spool) the turbine wheel, which is connected to the compressor wheel via a shared shaft.



1 A smaller turbo will spool quickly

2 At low engine speeds, apply full boost pressure

3 However, at high engine RPMs, boost pressure will drop.



1 In contrast, a larger turbo will take longer to spool

2 Thus, it will have a **turbo lag**



3 But it provides high-rev performance was improved at the expense of low-end response.

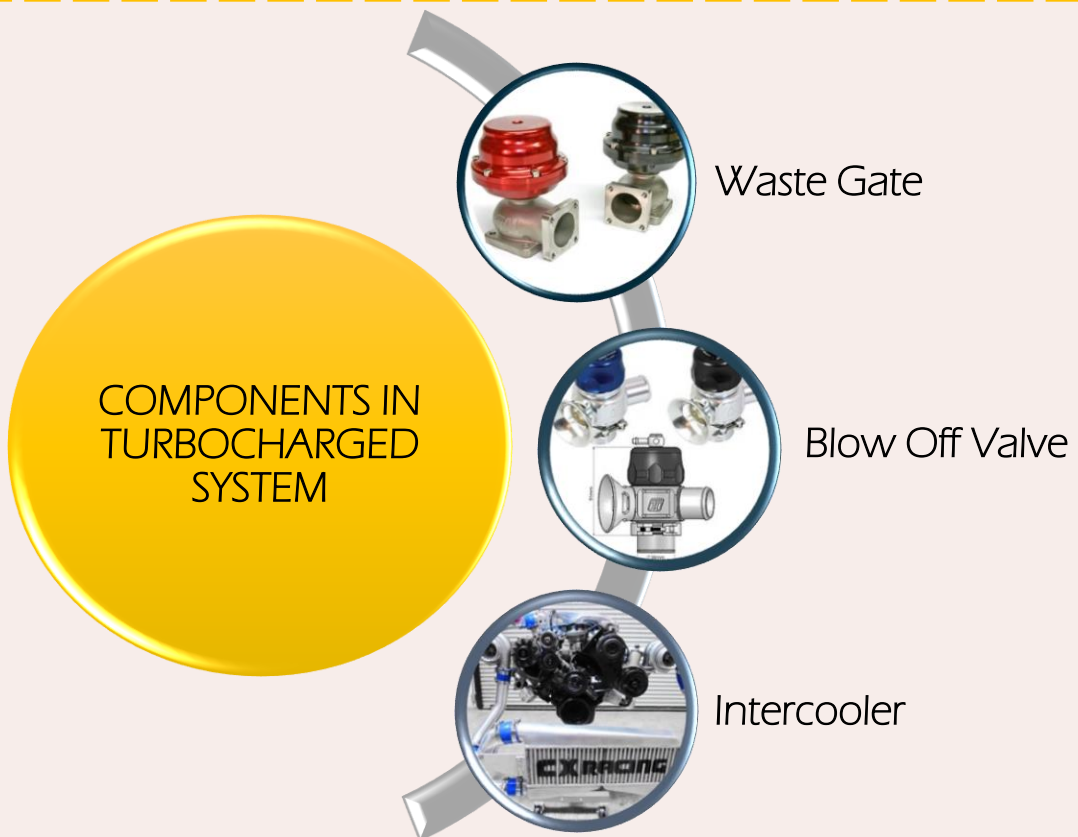

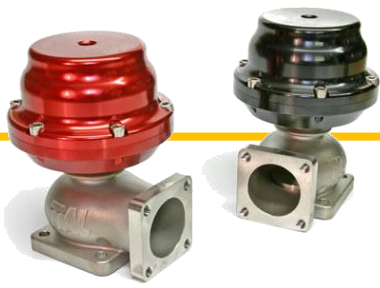

WASTE GATE

- A valve that allows the exhaust to bypass the turbine blades.

The boost pressure is detected by the waste gate

It's possible that if the pressure rises too high, the turbine is spinning too fast

As a result, the waste gate bypasses a portion of the exhaust surrounding the turbine blades.

The blades will be able to slow down as a result of this.

Operation Of Wastegate

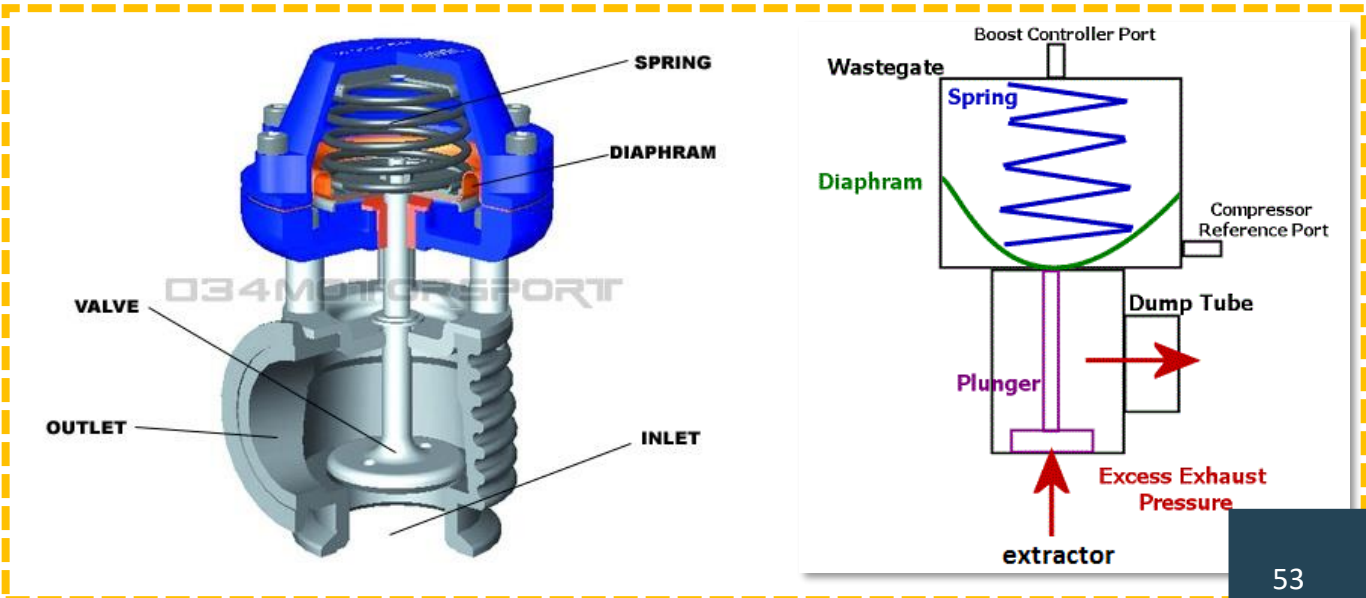
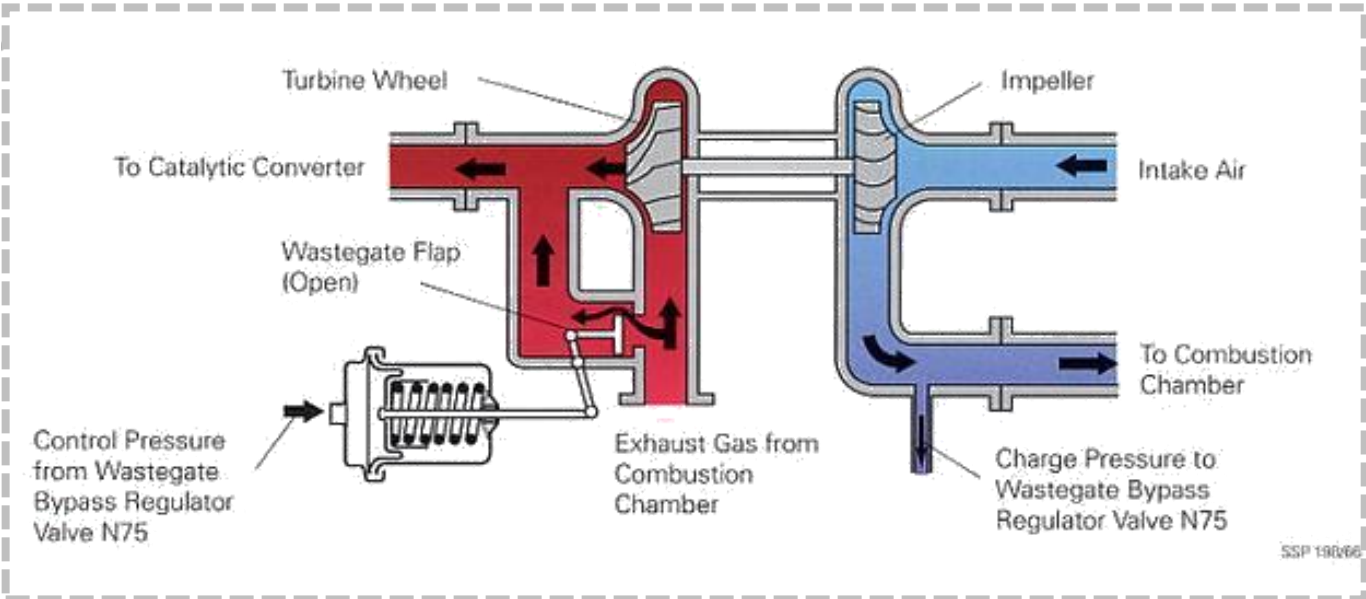

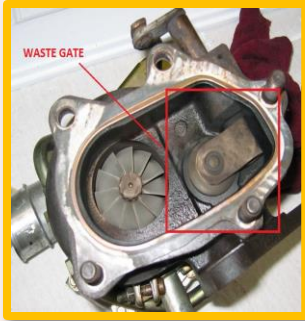

Internal

External



Mounting Position

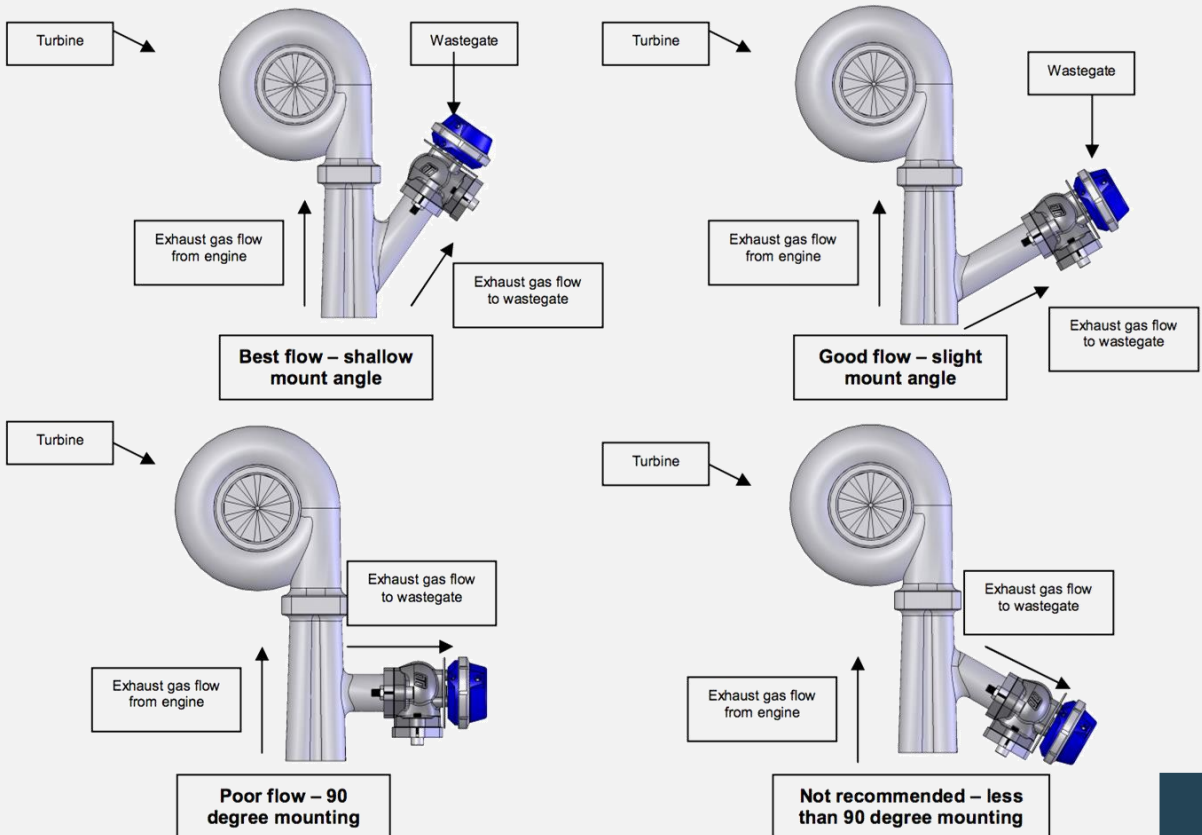

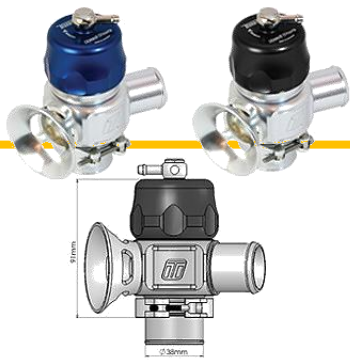

BLOW OFF VALVE

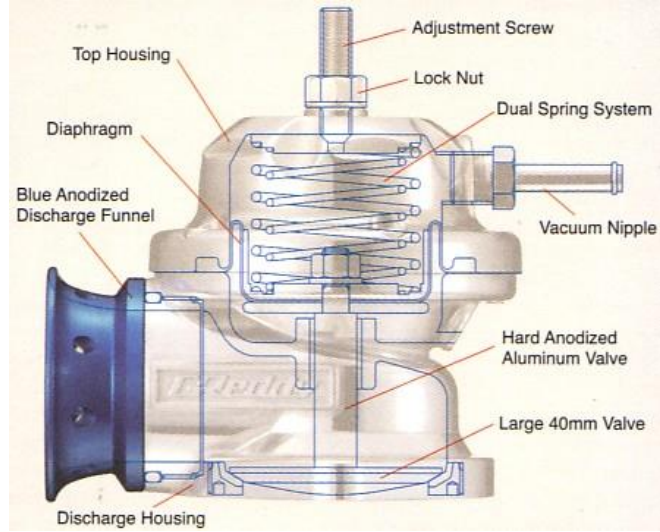

- Blow-off valves are used to prevent compressor surge
- When you lift the throttle off a turbocharged car that doesn't have a bypass valve, you get compressor surge.

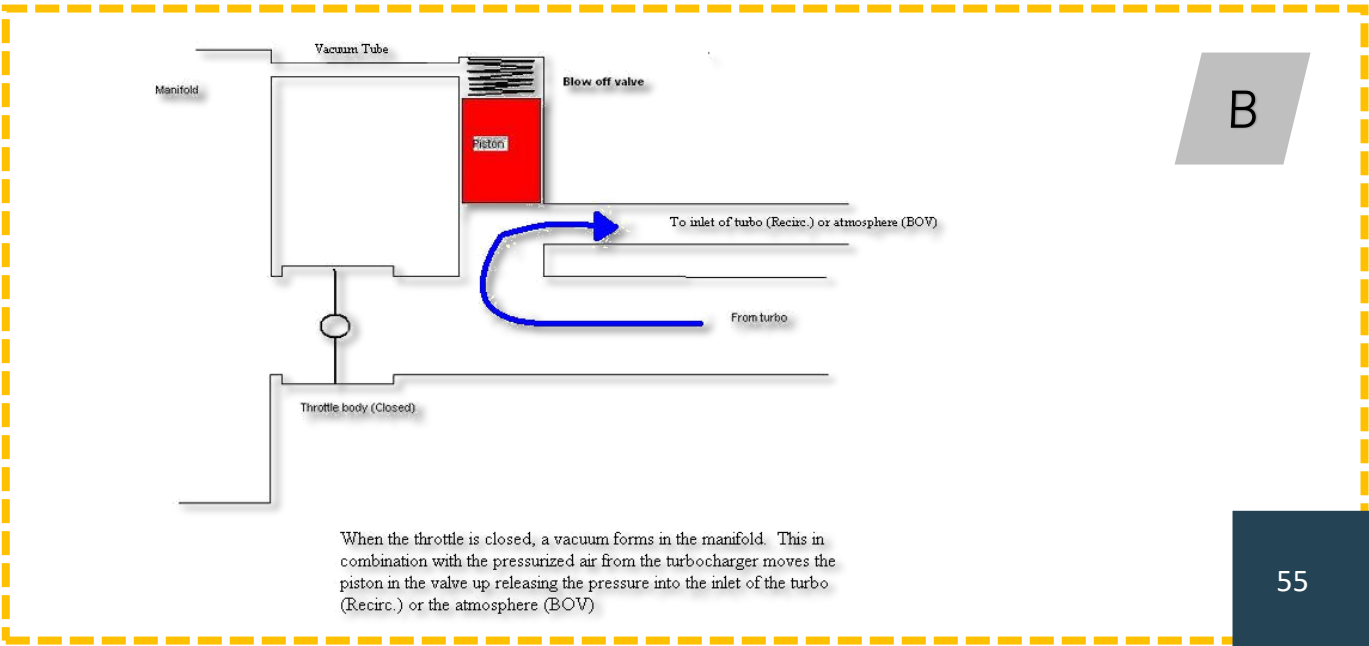
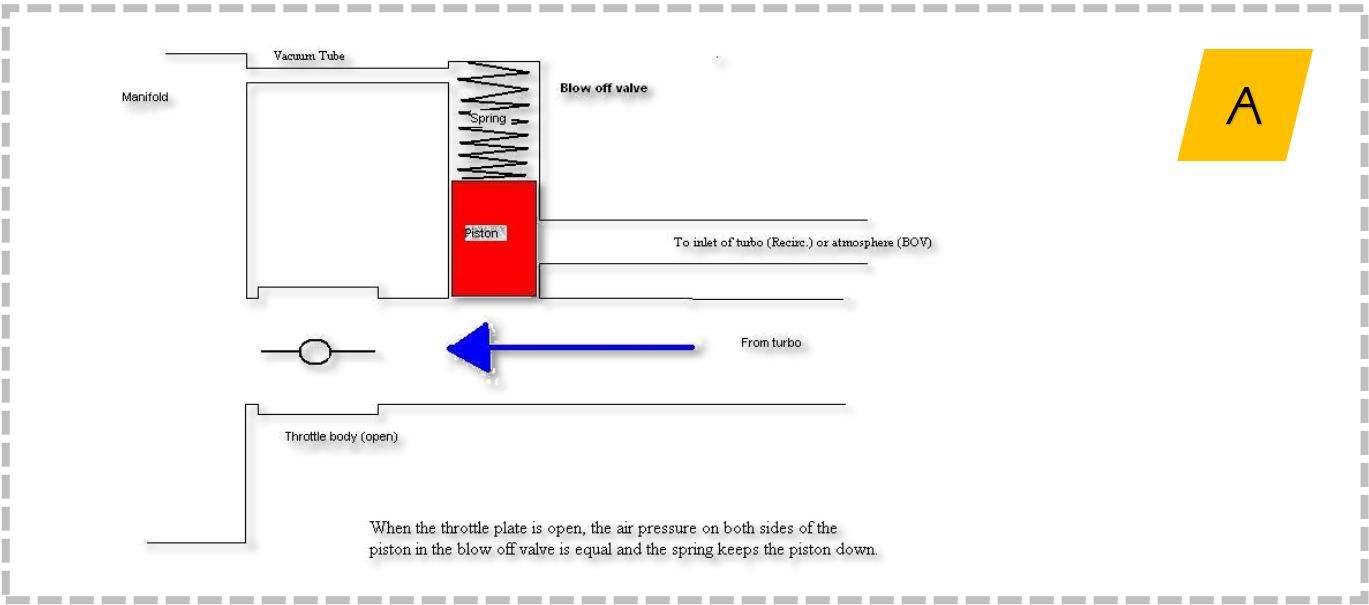

INTERCOOLER



- The aim of an intercooler is to cool air that has been compressed in a turbocharger or supercharger.
- When air is compressed, its temperature rises dramatically, making it less dense and oxygen-rich.
- In essence, an intercooler is a heat exchanger.

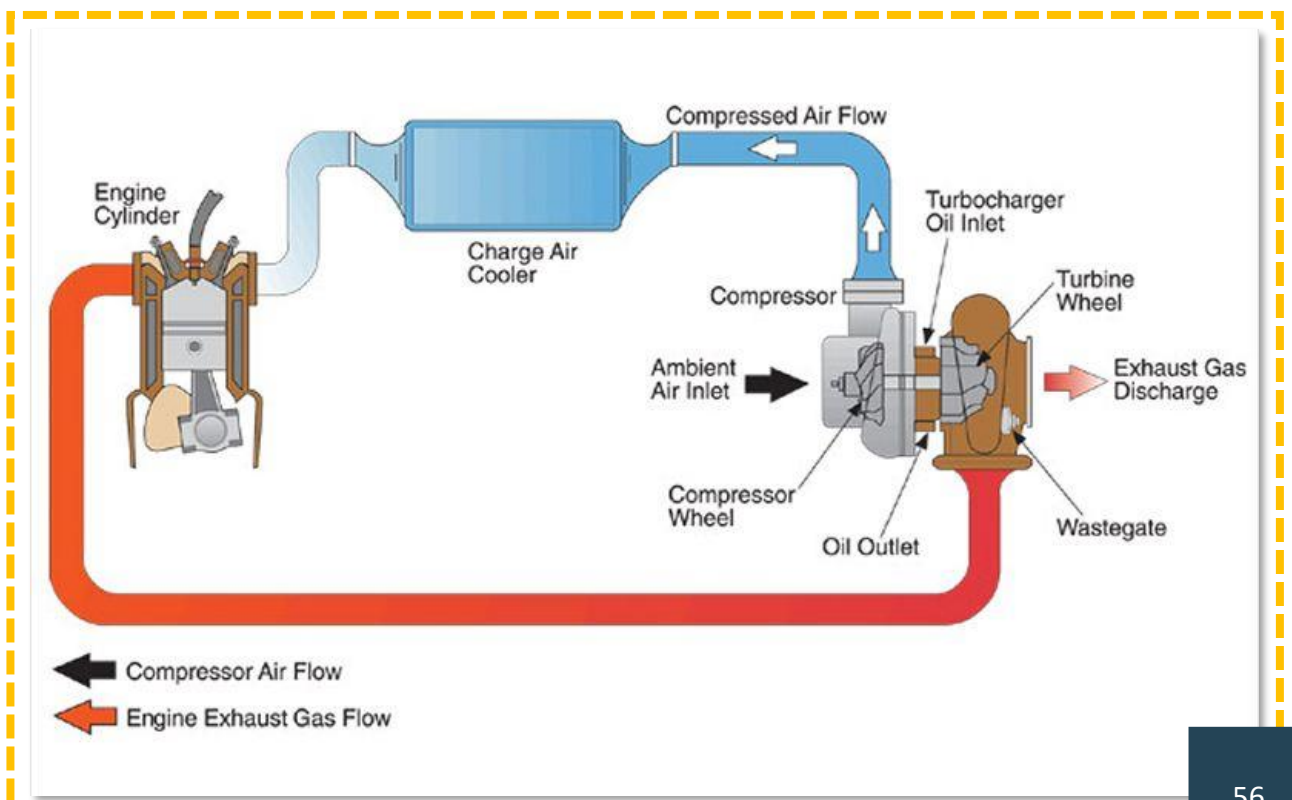
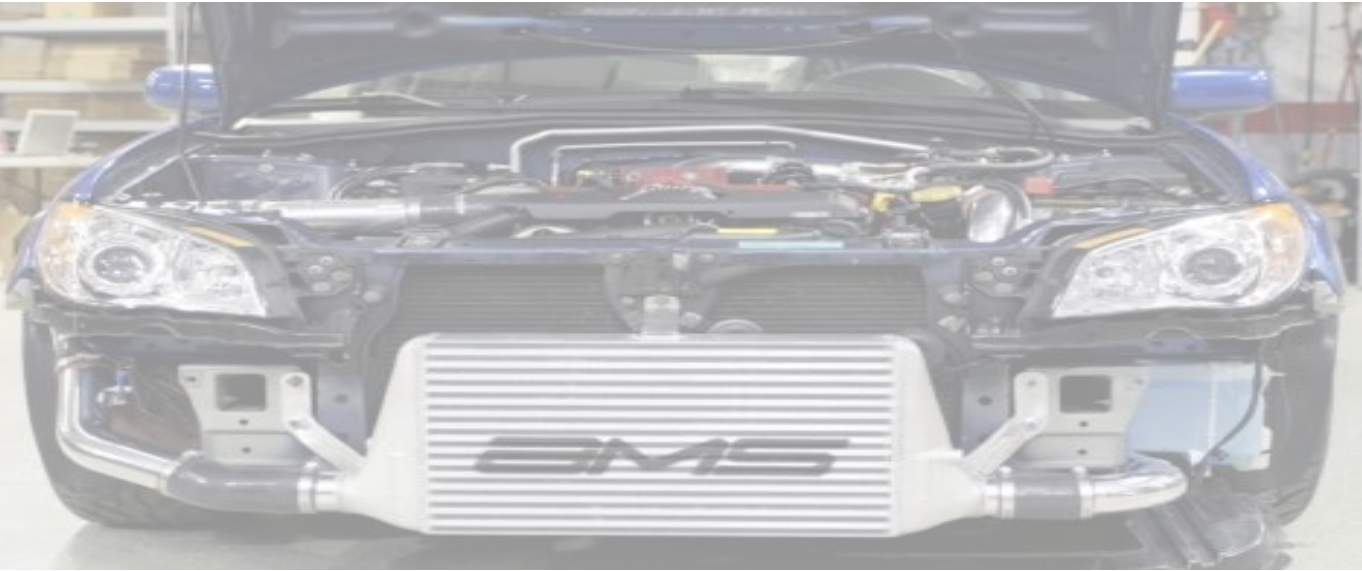



TURBO LAG



- Turbo lag is defined as the time gap (delay) between the throttle being pressed and the turbocharger responding, resulting in a delayed delivery of power.
- Turbo lag refers to the time it takes to create sufficient exhaust pressure to spin the turbo and pump compressed intake air into the engine.
- It lasts the longest while the motor is cruising at low rpm and low load.



How to reduce turbo lag?

- 1 Twin scroll turbo
- 2 Variable geometry turbo
- 3 Nitrous
- 4 Sequential turbo
- 5 Electric hybrid turbo

SUPERCHARGERS

POSITIVE DISPLACEMENT

At all speeds, positive-displacement pumps deliver a relatively constant volume of air every revolution.

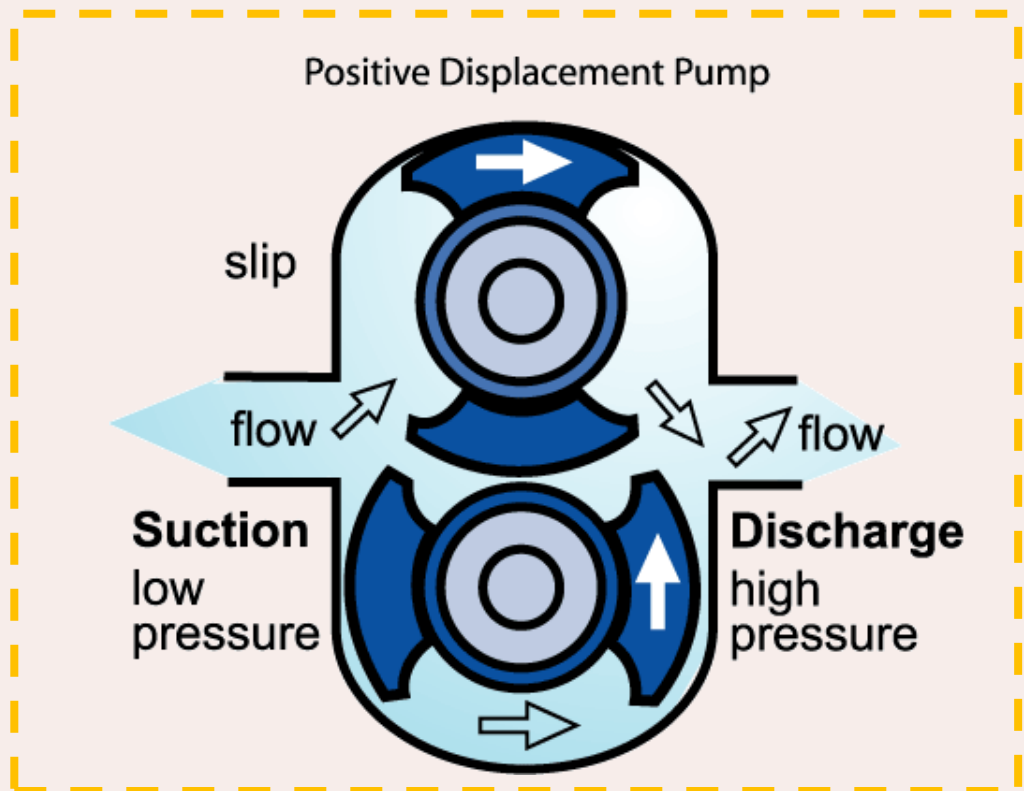

TYPES OF SUPERCHARGER

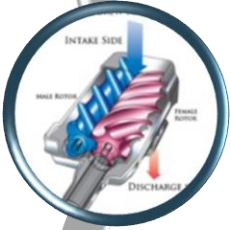
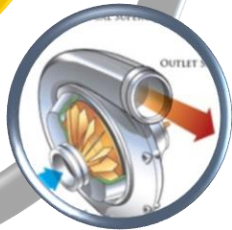
-  Roots
-  Lysholm Screw
-  Centrifugal

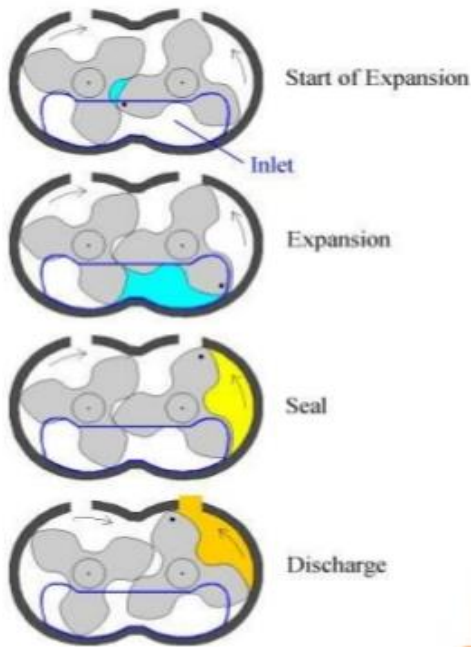

ROOTS TYPE

The Root type supercharger, also known as the Roots blower, is a positive displacement lobe pump that pumps fluids through a pair of meshing lobes that look like gears that have been extended. The fluid collects in pockets around the lobes and travels from the intake to the exhaust side.

SCREW TYPE

- Lysholm is also called screw type supercharger.
- The supercharger is made up of two screws, one of which has male threads. They are inextricably linked. Air is trapped between the screws and the housing as it is forced from the inlets to the outlet as they rotate. Furthermore, as the gap shrinks as it advances forward, the Lysholm supercharger conducts internal compression, allowing for higher boost pressure than Roots type superchargers.

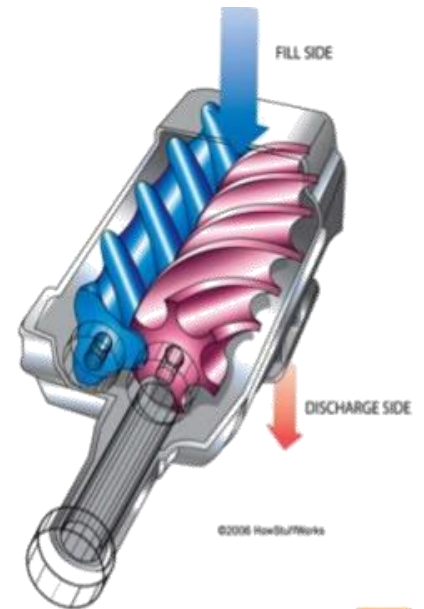

CENTRIFUGAL TYPE

The centrifugal type supercharger is an engine-driven compressor that increases the amount of accessible oxygen in an internal-combustion engine by reducing the amount of air that enters the engine. This type of supercharger operates similarly to a turbocharger, except that instead of exhaust gases driving the compressor through a turbine, the compressor is driven by a crankshaft belt, gear, or chain drive.

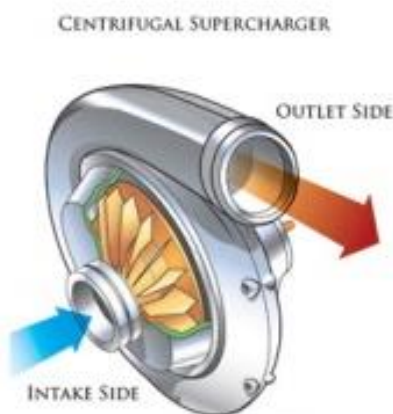

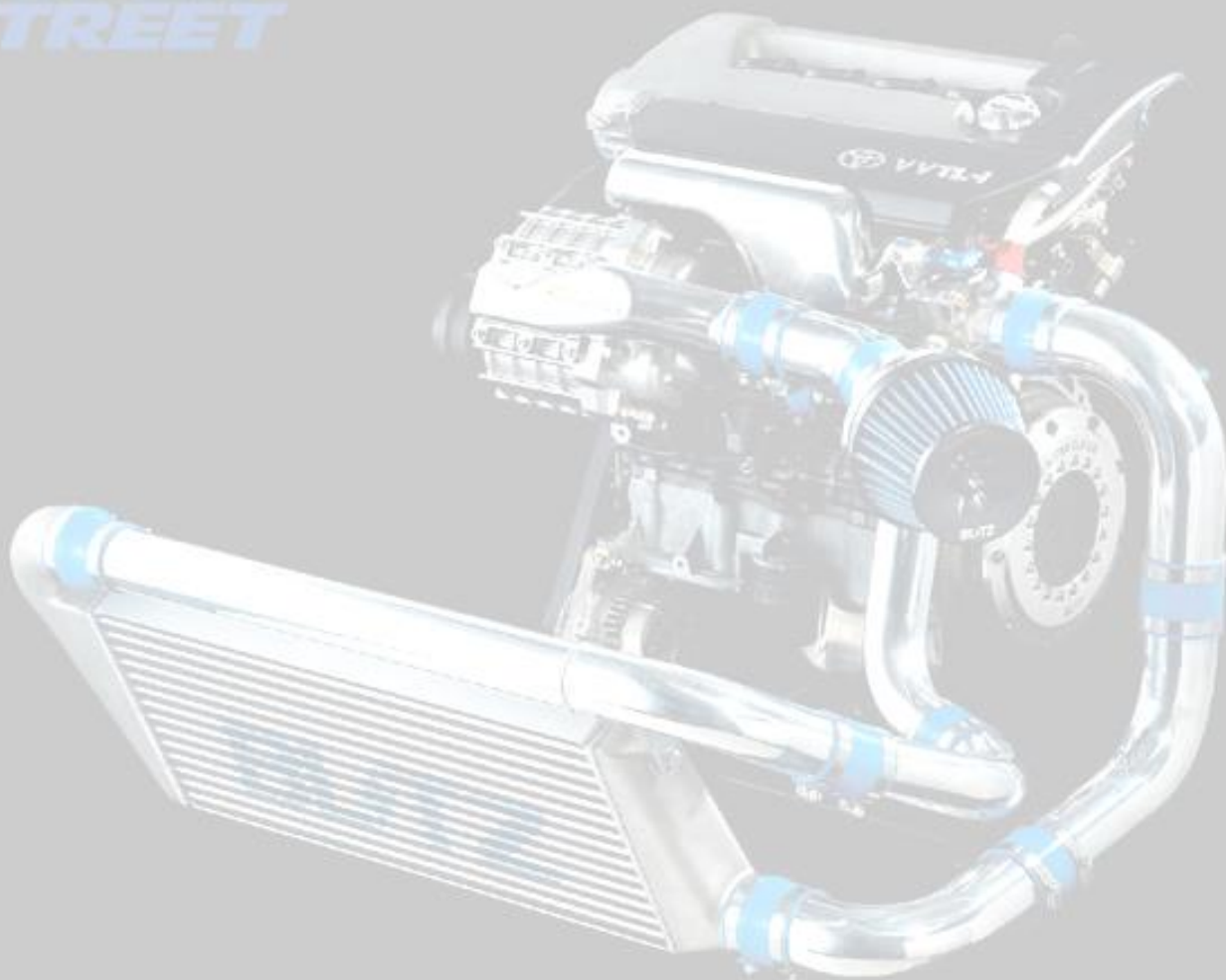

PROBLEMS WITH FORCED INDUCTION SYSTEM

1

The engine temperature is rising very quickly.

2

High combustion temperatures result in high NOx emissions, while high compression results in high combustion temperatures.

3

Another issue with high combustion temperatures is that the fuel can burn too quickly after the spark fires it or ignite before the spark ignites it. (called pre-ignition cause of knocking)

ADVANTAGES & DISADVANTAGES

FORCED INDUCTIONS SYSTEM

TURBOCHARGER

SUPERCHARGER

ADVANTAGES

- ✓ Increase the amount of horse power produced.
- ✓ Parts that are light
- ✓ Parts for superchargers are more expensive.
- ✓ Produce an infinite amount of boost

- ✓ Because the compressor spins appropriately to the engine speed, there is no lag time in building pressure.
- ✓ capable of maintaining the same boost pressure at all engine speeds
- ✓ Less parts (components)

DISADVANTAGES

- ✓ Have many parts (components)
- ✓ Having "Turbo Lag" (lagging time), need time to turbo spool up.
- ✓ Need additional parts to cooling the air entering combustion chamber (intercooler)

- ✓ Need more space to installation of superchargers.
- ✓ More expensive than Turbochargers.

QUESTION CHAPTER 2

1. What is Forced Induction System?

Force Induction is forcing additional into the cylinder, a mixture of air and gasoline is injected. The process of forcing compressed air into an internal combustion engine's intake is known as forced induction.

2. Explain with the diagram of the air induction system in a vehicle and explain its operation.

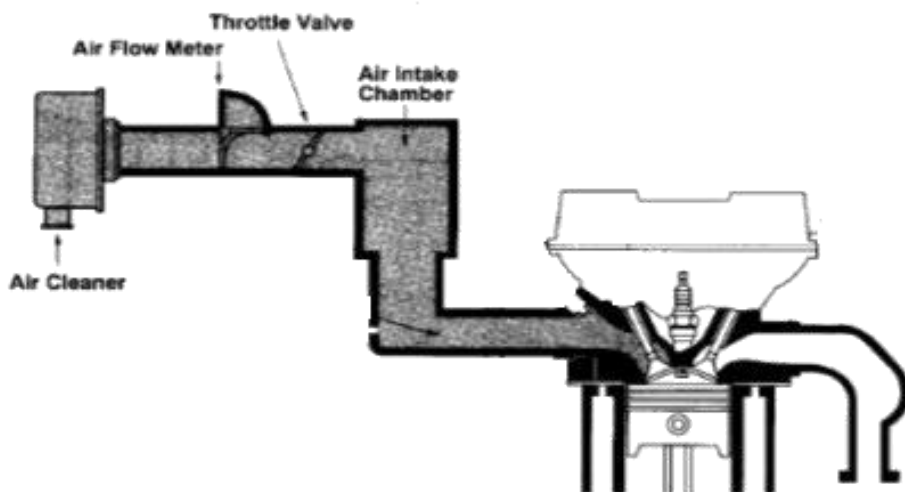

- i. Air flows through the air cleaner when the throttle valve is opened to be filtered.
- ii. Then air will go past the throttle valve (on L type systems) and through the air flow metre in throttle body.
- iii. ECU will determine the air fuel ratio based on the throttle position sensor's input. Then, air will be channeled to the intake valve via a well-tuned intake manifold runner before entering the cylinder.

3. Write the meaning of a 'turbo lag' in the Forced Induction System and give the solution to reduce a turbo lag in the system.

'Turbo lag' is a time required to boost the pressure and rotate the turbine. The solution to reduce turbo lag is using supercharger and use a small turbocharger.

- a. Give the types of Supercharger System
- b. Root Supercharger
- c. Twin-Screw Supercharger
- d. Centrifugal Supercharger

4. Sketch and explain the operation of Turbocharger System.

- a. The turbine wheel and wheel compressor, which are attached on the same axis, are rotated using the energy from the engine exhaust gases. This forces air into the engine by compressing it.
- b. Boost pressure refers to the quantity of air (pressure) forced into the engine and can be altered by adjusting the amount of exhaust (blow off)
- c. The bypass valve (waste gate) between the engine and the turbo adjusts the gas that travels through the turbo and releases the exhaust gas without passing through the turbo.
- d. The compressor pressure activates this, allowing the engine to take in more air by increasing boost pressure.

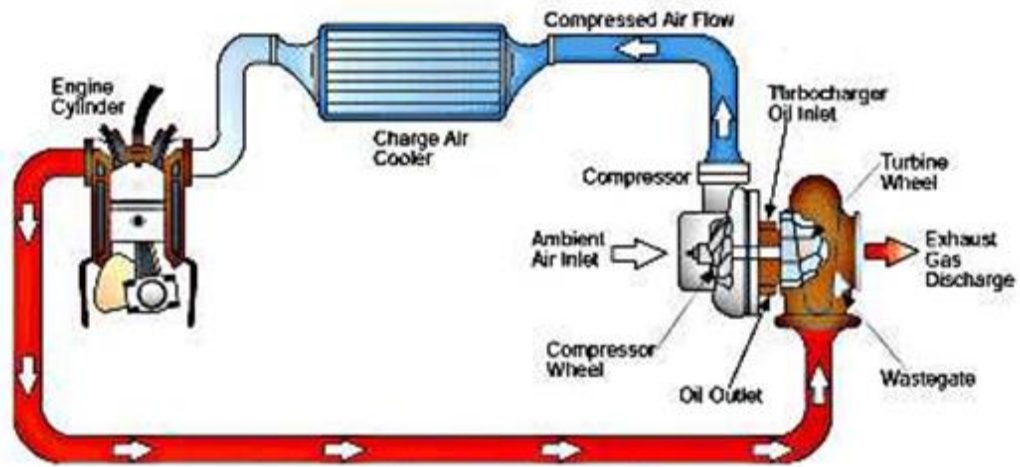

5. Elaborate the working operation of a supercharger system.
- i. Without creating a vacuum, superchargers enhance intake by compressing air above atmospheric pressure. This "boosts" the engine by forcing more air into it. More fuel can be supplied to the charge, and the engine's power is increased, thanks to the more air in the boost.
 - ii. The power for superchargers comes directly from the crankshaft. Auxiliary belts that wrap around a pulley connected to a driving gear power the bulk of them. The drive gear rotates the compressor gear.
 - iii. The compressed air exiting the discharge unit must be cooled before entering the intake manifold for a supercharger to perform at maximum efficiency. This cooling procedure is handled by the intercooler.

6. Explain the advantages of the EFI system as compared to the carburetor system.

i. **Uniform Air/Fuel Mixture Distribution**

Each cylinder has its own injector that supplies gasoline to the intake valve directly. Fuel does not have to go via the intake manifold as a result of this.

ii. **Controlling the Air/Fuel Ratio with Extreme Precision**

Regardless of the Engine's Operating Conditions Regardless of the under normal operating conditions, EFI supplies the engine with a precise air/fuel ratio. Performance, fuel economy, and pollution control are all improved as a result of this.

iii. Improved Emissions Control and Excellent Fuel Economy

Fuel puddling in the intake manifold is not a concern with an EFI engine, so the effects of a cold engine and a wide open throttle can be reduced. As a result, overall fuel economy and emissions management are enhanced.

iv. Ability to start and operate a cold engine has been improved

A combination of improved fuel atomization and injection directly at the intake valve improves the ability to start and run a cold engine.

v. Superior Power and Throttle Response

By delivering fuel directly to the back of the intake valve, the intake manifold design can be changed to increase air velocity at the intake valve. Torque and throttle response are improved as a result.

7. Sketch and explain the working operation of a wastegate in turbocharger system.

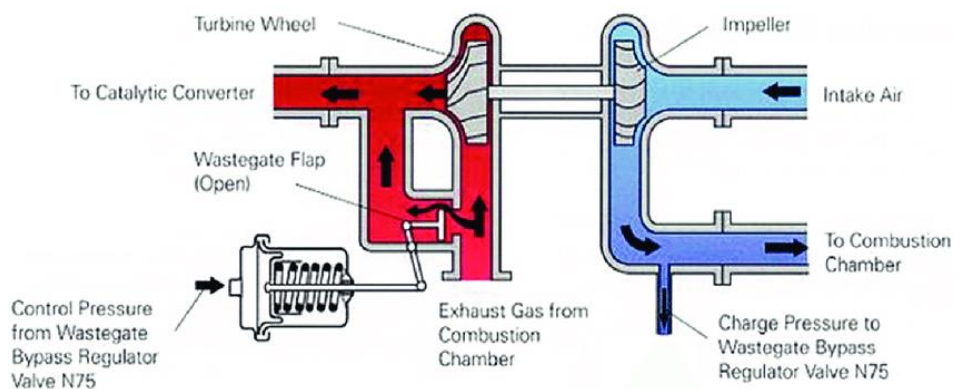

- A valve that permits exhaust to flow around the turbine blades instead of through them.
- They limit the exhaust gases that flow through the turbocharger. Therefore, it controls the maximum boost pressure produced by the turbocharger itself.

CHAPTER 3

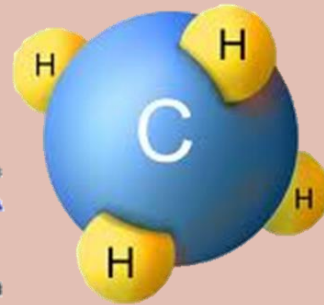
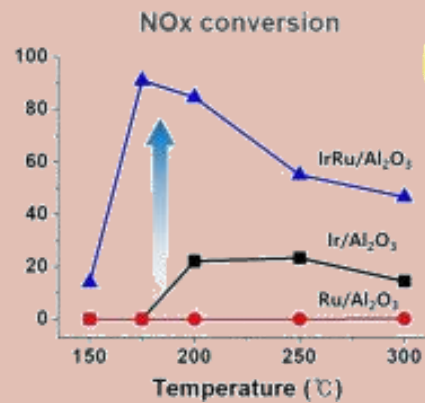
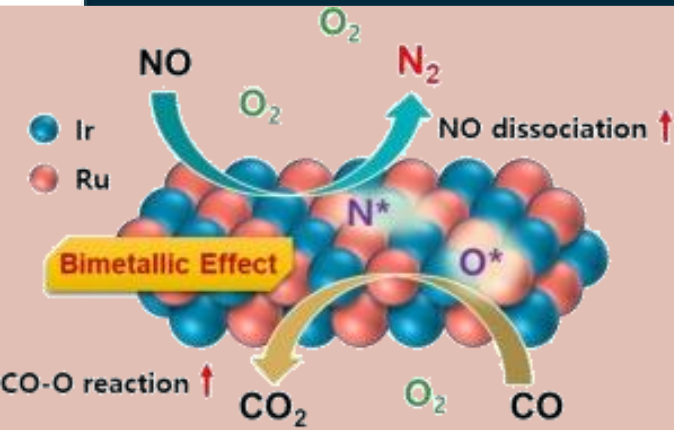

EMISSION CONTROL SYSTEM

OBJECTIVES

Classify types of vehicle emission sources

1

Identify exhaust emission pollutants and their effects to human health

- a. hydrocarbon, HC
- b. carbon monoxide, CO
- c. oxide of nitrogen, NO_x
- d. particulate matter, PM
- e. Sulfur Oxide, SO_x

2

Identify fuel evaporation sources

3

Describe "blow-by gas"

Emission control systems

1

Identify types of emission control systems

- a. Catalytic Converter
- b. Exhaust Gas Recirculation Systems, EGR
- c. Positive Crankcase Ventilation System, PCV
- d. Evaporative Emission Control System, EVAP
- e. Secondary Air Injection System

2

Describe overall layout of emission control systems

3

Identify components name, function and location of emission control system

3.1 TYPES OF VEHICLE EMISSION SOURCES

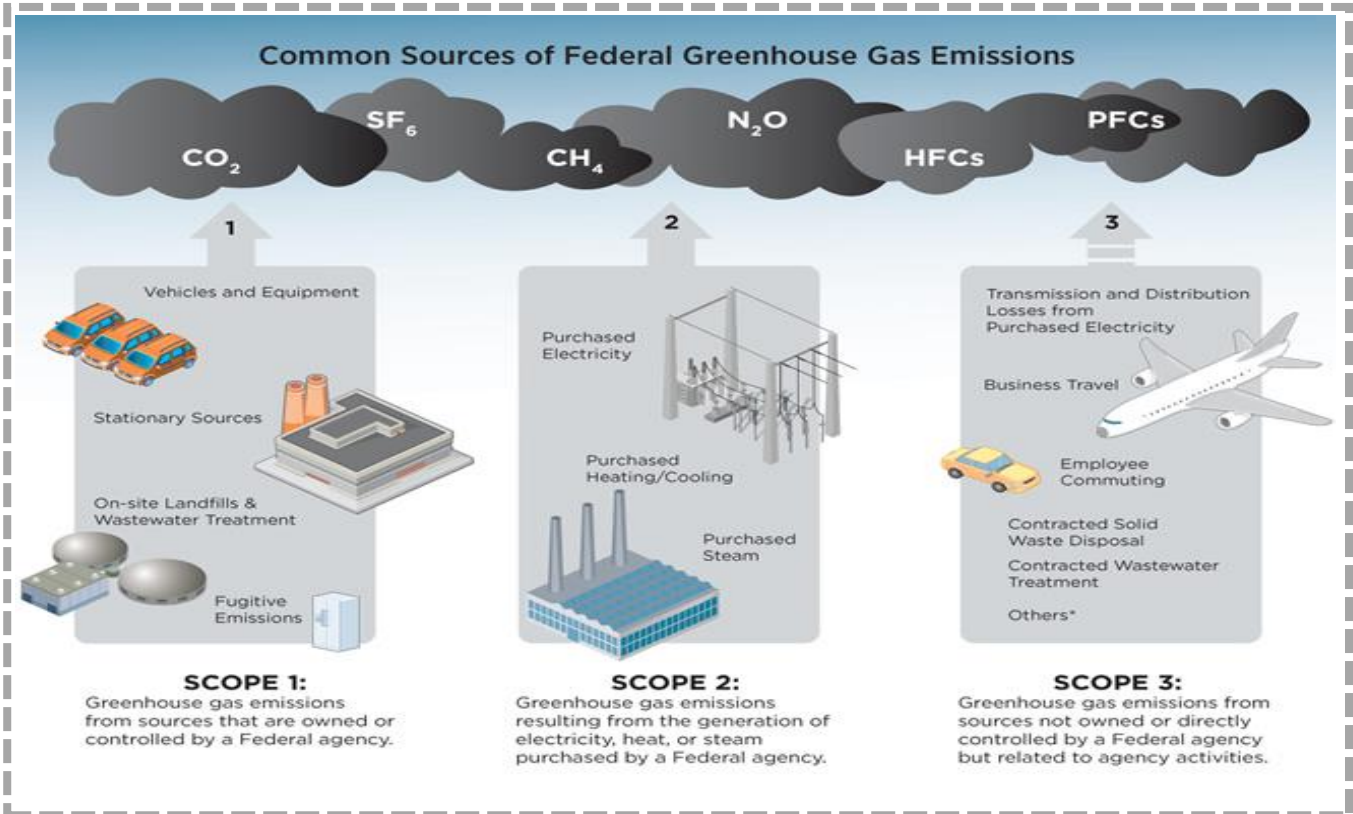

3.1.1 EXHAUST EMISSION POLLUTANTS AND THEIR EFFECTS TO HUMAN HEALTH

AIR POLLUTANTS

| POLLUTANT | SOURCES | HEALTH EFFECTS |
|---|--|---|
| Sulfur oxides, Particulates | Coal and oil power plants Oil refineries, smelters Kerosene stoves | Bronchoconstriction Chronic bronchitis Chronic obstructive lung disease |
| Carbon monoxide | Motor vehicle emissions Fossil fuel burning | Asphyxia leading to heart and nervous system damage, death |
| Oxides of nitrogen (NO_x) | Automobile emissions Fossil fuel power plants Oil refineries | Airway injury Pulmonary edema Impaired lung defenses |
| Ozone (O_3) | Automobile emissions Ozone generators Aircraft cabins | Same as NO_x |
| Polycyclic aromatic hydrocarbons | Diesel exhaust Cigarette smoke Stove smoke | Lung cancer |
| Radon | Natural | Lung cancer |
| Asbestos | Asbestos mines and mills Insulation Building materials | Mesothelioma Lung cancer Asbestosis |
| Arsenic | Copper smelters Cigarette smoke | Lung cancer |
| Allergens | Pollen Animal dander House dust | Asthma, rhinitis |

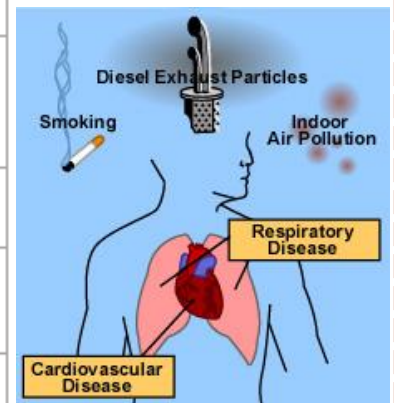

TYPES OF VEHICLE EMISSION SOURCES

1

HYDROCARBON (HC)

- In the form of unburned gasoline
- Incomplete burning of any organic matter or combustion engine exhaust

Effects

- Reduce the amount of oxygen that is available
- Considered dangerous air pollutants, often known as air toxins, can cause cancer

2

OXIDE OF NITROGEN (Nox)

- When the heat in the engine causes nitrogen in the air to mix with oxygen, this is produced within the combustion chamber
- Nitrogen dioxide (NO₂) is a gas with a harsh, biting odour and a reddish-brown hue

Effects

- Irritation of the eyes in general
- The respiratory system is irritated
- Breathing problems

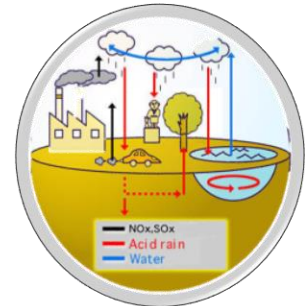

3

PARTICULAR MATTER (PM)

Particular matters are either classified as:-

- Primary particulates
 - ✓ road traffic, which is directly discharged into the atmosphere
- Secondary particulates
 - ✓ created in the atmosphere, such as sulphur dioxide oxidation to sulphuric acid.

Effects

- Cardiovascular
- Respiratory problems

CARBON MONOXIDE (CO)

- Carbon monoxide is a colourless, odourless gas that is extremely dangerous to people
- Carbon dioxide is produced when carbon-based fuels are burned(CO_2)

Effects

- Central nervous system and heart toxicity
- Effects on a pregnant woman's baby are severe
- Dizziness and headaches
- There are issues with delivering oxygen to various bodily areas that could be life-threatening

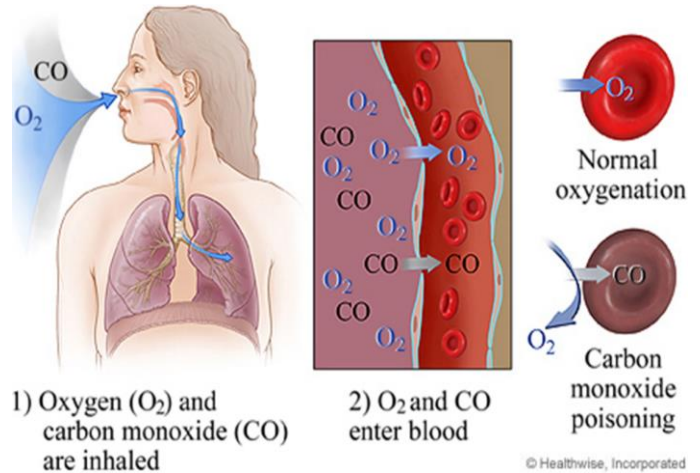

How CO become higher :-

- Air filter that is clogged - A clogged air filter restricts air flow, making it difficult to breathe
- disturbing the ratio of air / fuel(14.7:1) needed for optimum
- combustion of fuel
- Defective Oxygen sensor (O₂ sensor)
- Defective MAP sensor - A faulty MAP sensor will not generate a report
- incorrect information to the ECU, causing the air/fuel ratio to be disturbed
- Defective Throttle Position Sensor (TPS) - confuses the ECU to decide if the gasoline is too much or too little, when it is really not necessary
- Engine Coolant Temperature (ECT) Sensor Failure – Low engine temperatures necessitate the use of more fuel. When the ECU is unable to identify the engine's precise temperature, it can not determine the rate of the fuel properly and causes high CO

HEALTH EFFECTS OF POLLUTION

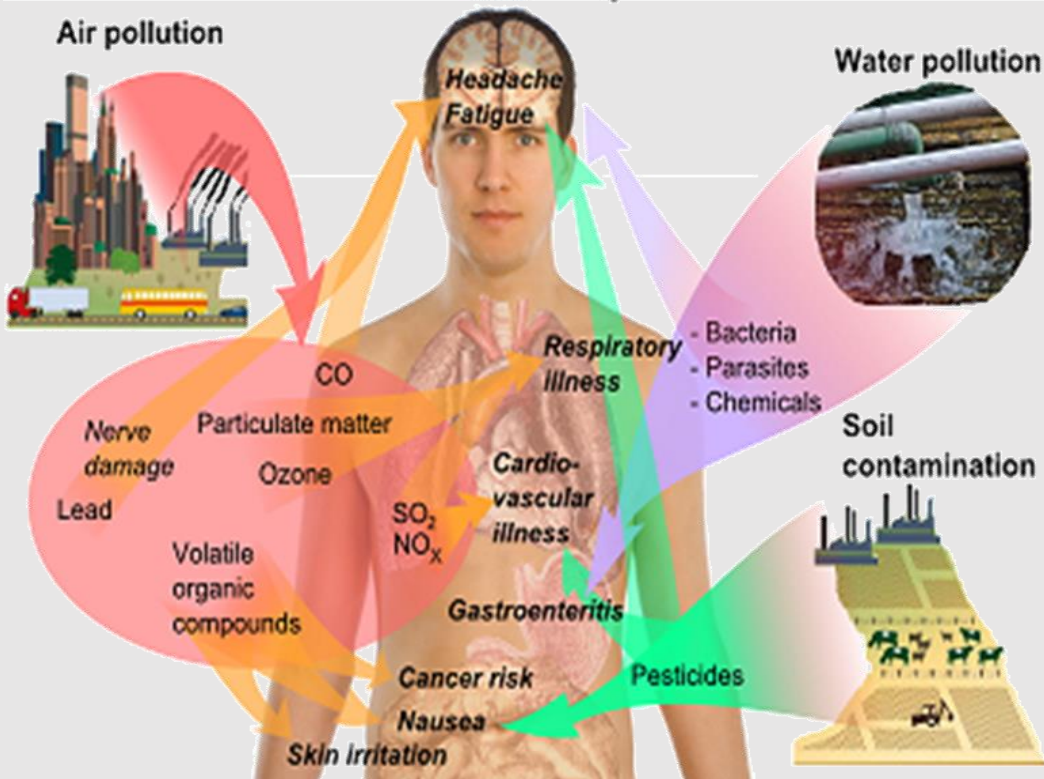

What happens during combustion:

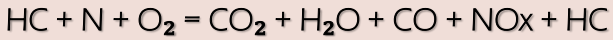

* It's worth noting that HC is on the right side of the equation. This demonstrates that some gasoline does not burn completely and escapes into the exhaust gas.

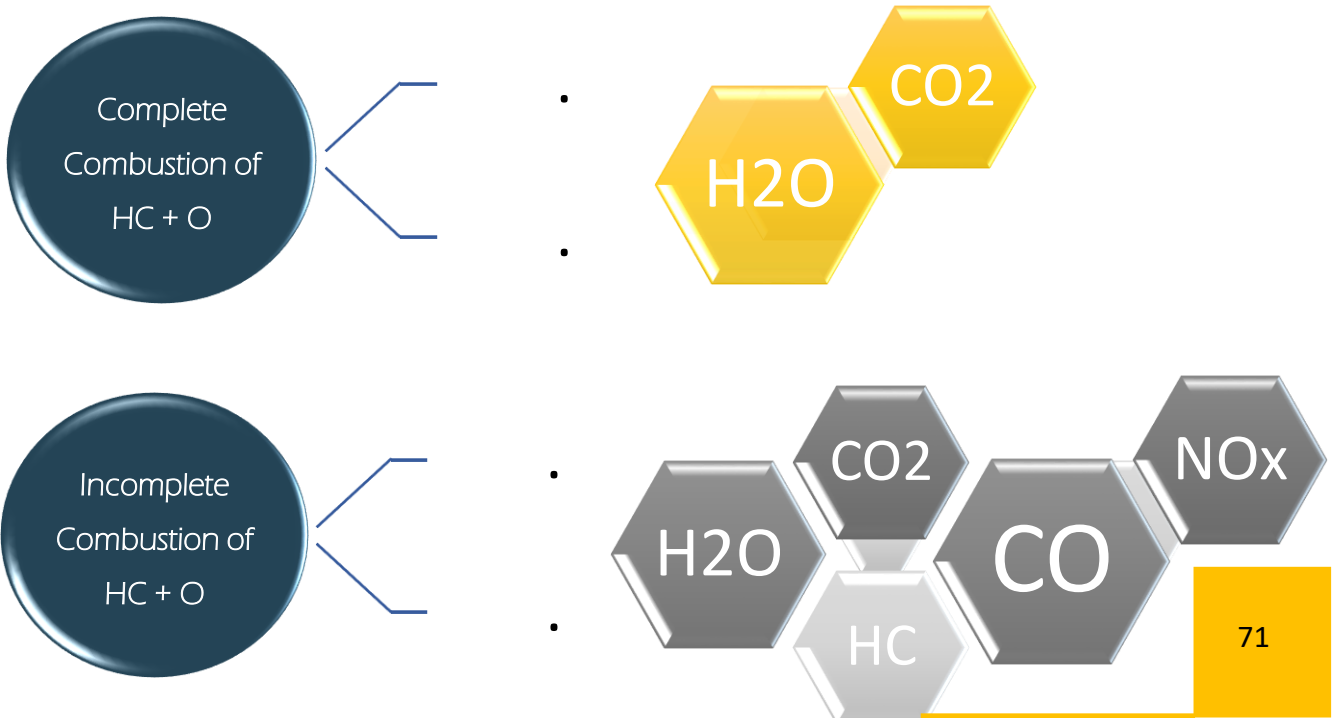

SULFUR OXIDE (SO_x)

- When sulfur-containing fuels (coal and oil) are burned, sulphur dioxide is produced
- Oxides react with other substances in the air to form a haze that makes visibility difficult

Effects

- Lung function is impaired.
- Incidence of respiratory symptoms and illnesses has increased
- Eye, nose, and throat irritation

3.1.2 FUEL EVAPORATION SOURCES

There are FOUR basic ways in which gasoline vapours might cause harm;

1. Daily evaporation (Sejatan Harian)

- Occurs during the daylight hours when the fuel is heated by an increase in ambient temperature. The rise in temperature increases vaporization.

2. Running losses (Kehilangan semasa berjalan)

- The exhaust system and engine activity both generate heat in the engine compartment, which causes gasoline evaporation.

3. Hot soak (Serapan)

- After an engine is turned off, the radiant heat will cause gasoline vaporization for an extended period as long as one hour

4. The time of refueling (Masa isi minyak)

- Gasoline vapours are present in the fuel tank at all times. When liquid fuel is added to the tank, the fumes are displaced and vented into the atmosphere.

3.1.3 BLOW-BY GAS

Blow-By: on other side also

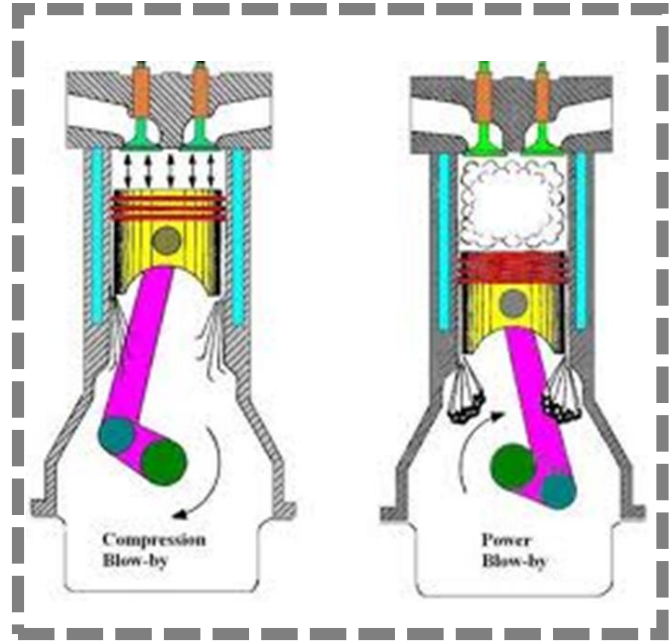

- Leakage of the air-fuel mixture or combustion gases into the crankcase of an automobile between a piston and the cylinder wall

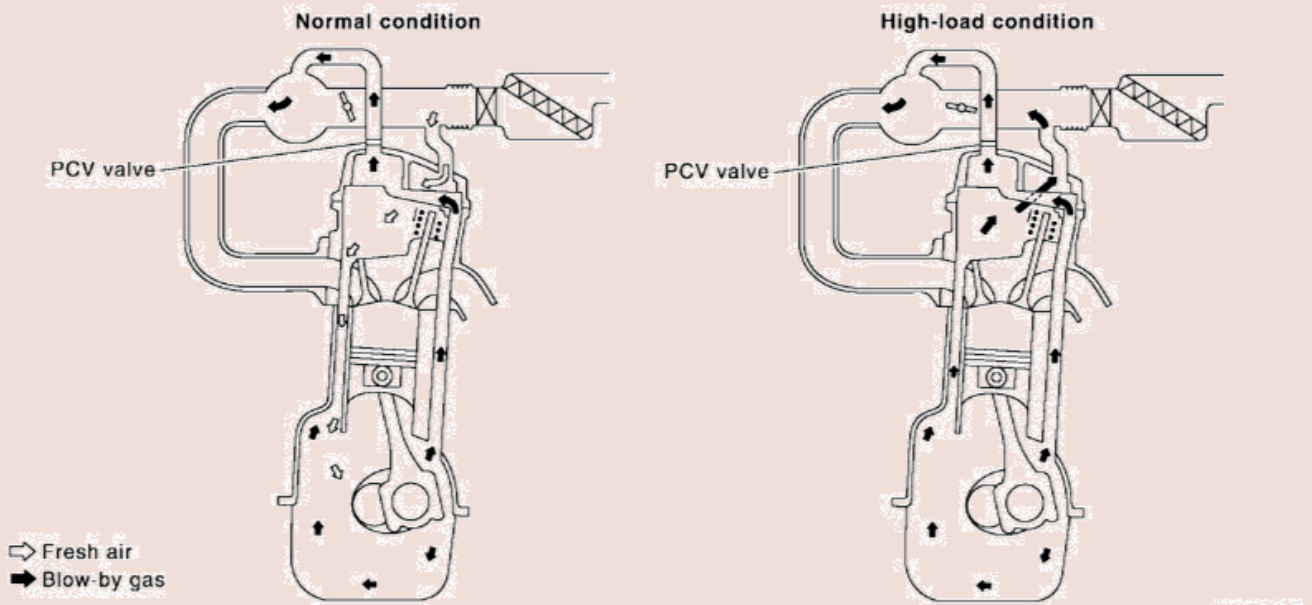

- When the engine is running, some combustion gases seep down into the crankcase between the piston rings and the cylinder walls
- Water from condensate and unburned fuel also find their way into the crankcase and sump

TYPES
OF
EMISSION
CONTROL

1. Catalytic Converter



1. Exhaust Gas Recirculation Systems, EGR

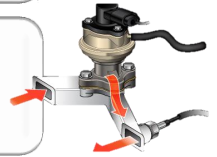

1. Positive Crankcase Ventilation System, PCV



Secondary Air Injection System

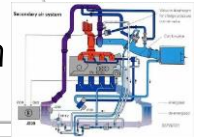

Evaporative Emission Control System, EVAP

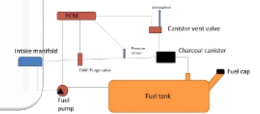

CATALYTIC CONVERTER

A

EXHAUST MANIFOLD

Designed to guide gases from the engine cylinders towards the exhaust system.

B

CATALYTIC CONVERTER

Designed to limit the amount of dangerous polluting gases in the atmosphere

C

CENTER SECTION

Some vehicles feature a center section designed to reduce noise.

D

MUFFLER

Designed to minimise noise even more and direct exhaust gases away from the vehicle.

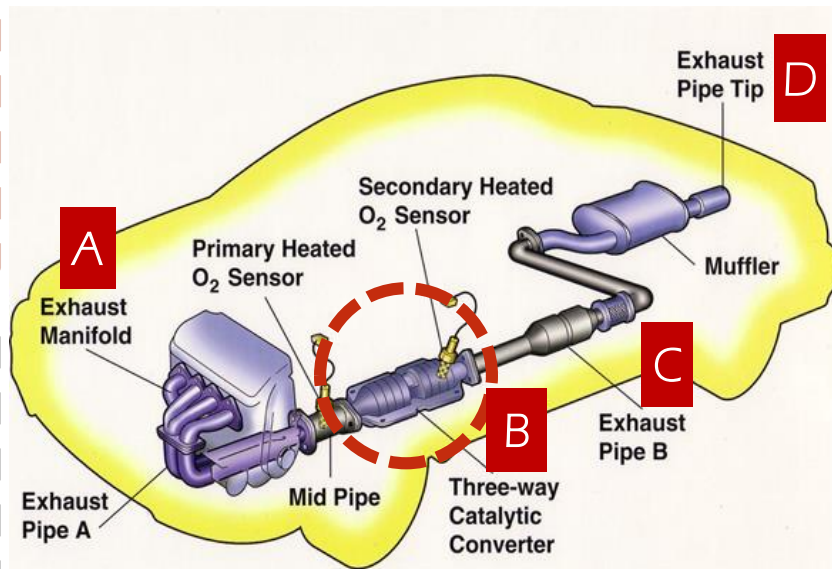

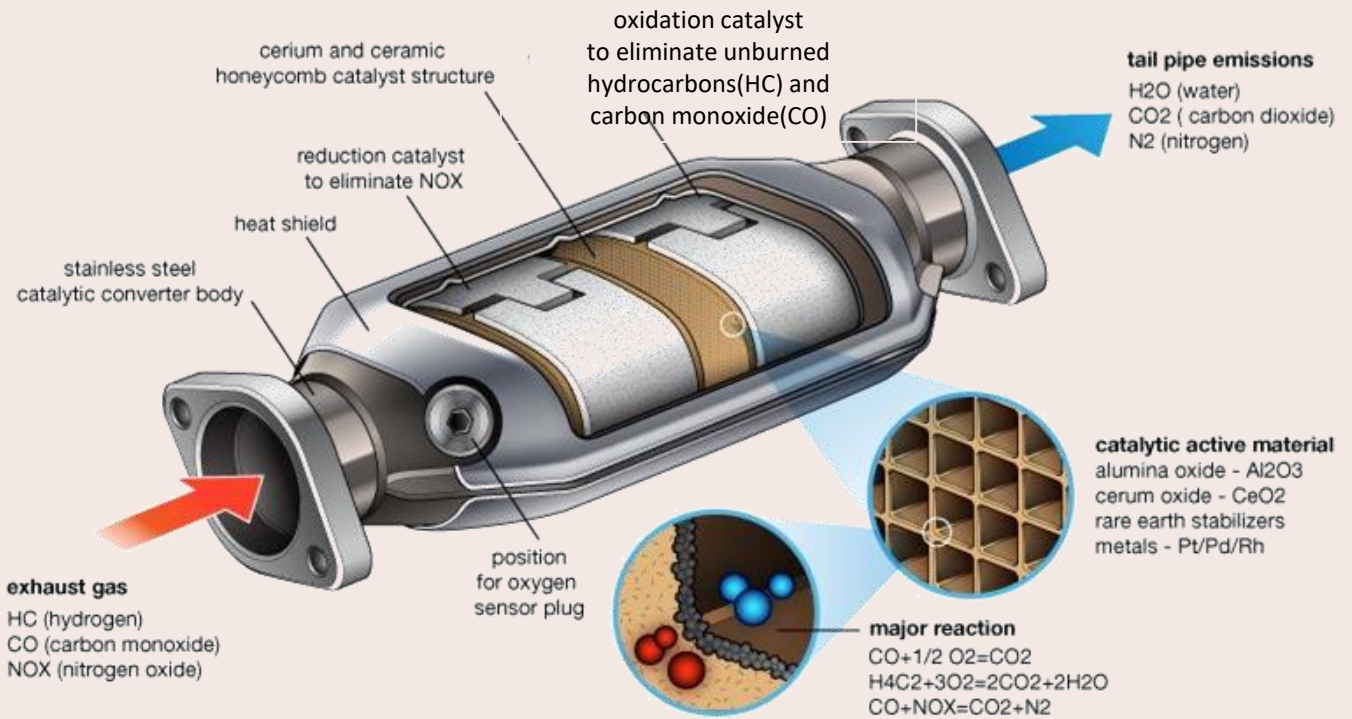

Exhaust And Emission System

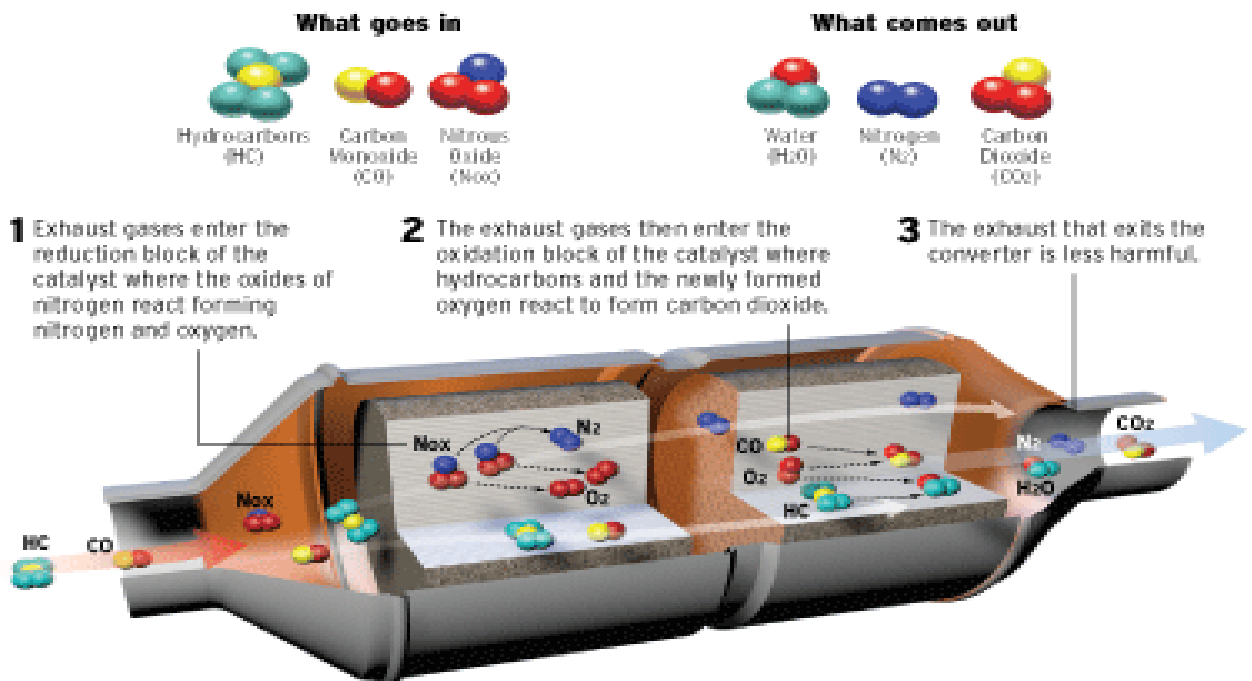

How A Catalytic Converter Works

The catalyst aids in the conversion of carbon monoxide to carbon dioxide.

The hydrocarbons are converted to carbon dioxide and water / nitrogen and oxygen

TWO different types of catalyst

1. reduction catalyst (*pengurangan*)
- platinum + rhodium
2. oxidation catalyst (*pengoksidaan*)
- platinum + palladium

Effects

Carbon monoxide is poisonous to anyone who breathes air

Smog and acid rain are caused by nitrogen oxides, whereas smog is caused by hydrocarbons

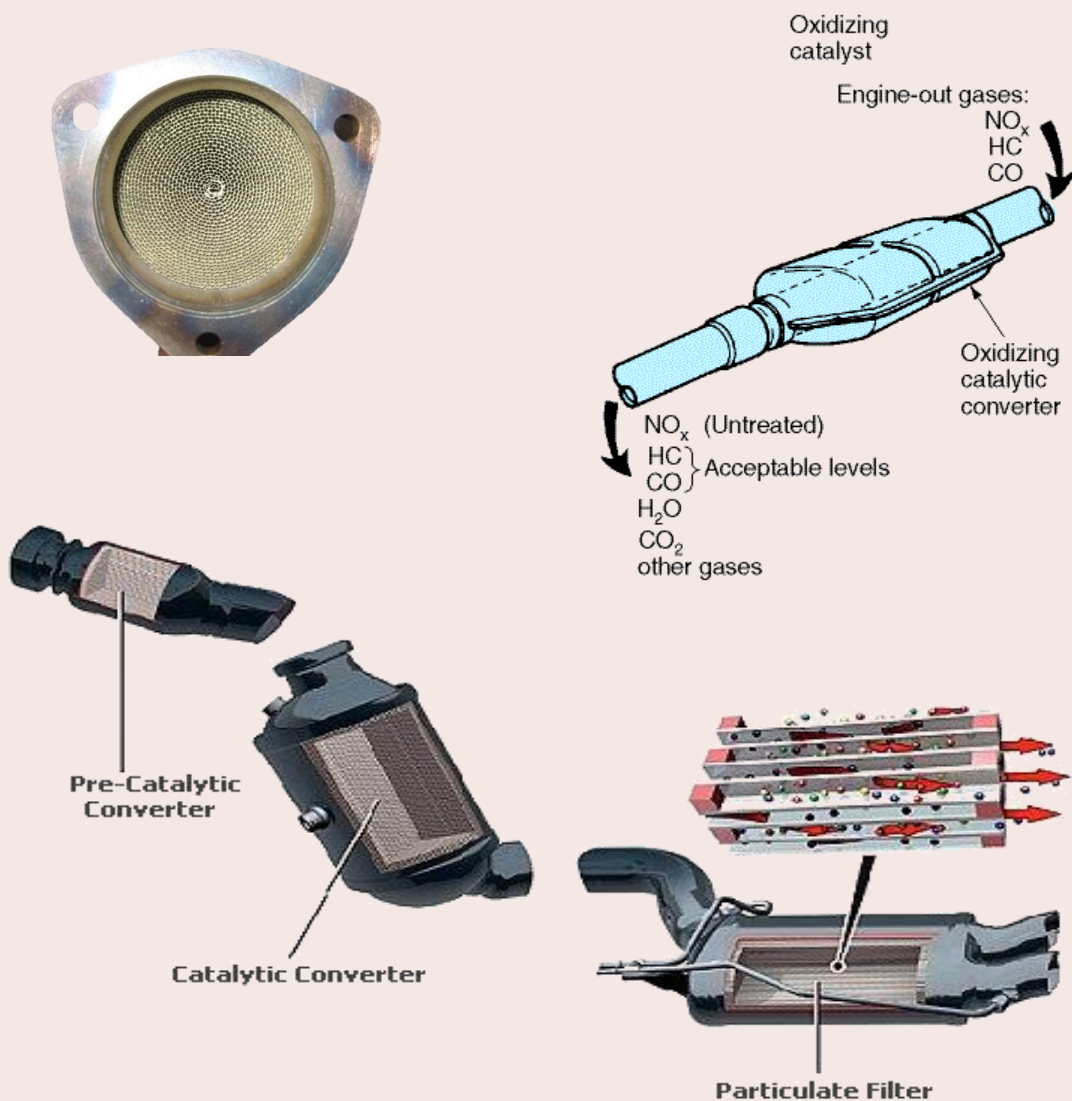

EXHAUST GAS RECIRCULATION (EGR)

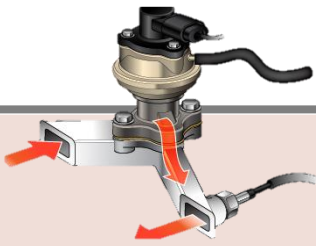

- Controls the amount of smog-causing nitrous oxides emitted by an engine (NOx)
- To route a portion of the exhaust gases back into the intake manifold
- This reduces peak in-cylinder temperatures by diluting the O₂ in the incoming air stream and providing inert gases to function as heat absorbents during combustion
- Because NO_x is formed largely when a mixture of nitrogen and oxygen is exposed to high temperatures, EGR minimises the quantity of NO_x produced.

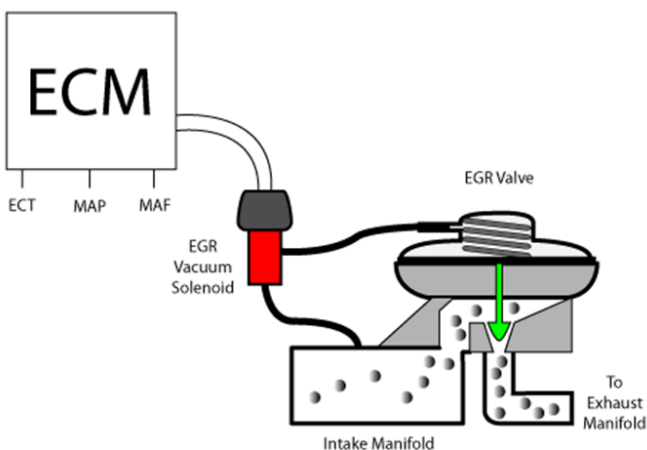
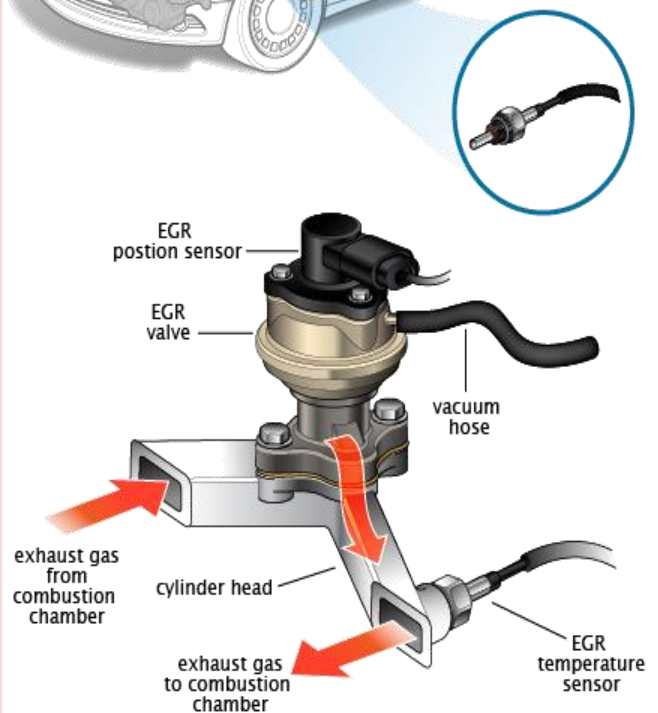
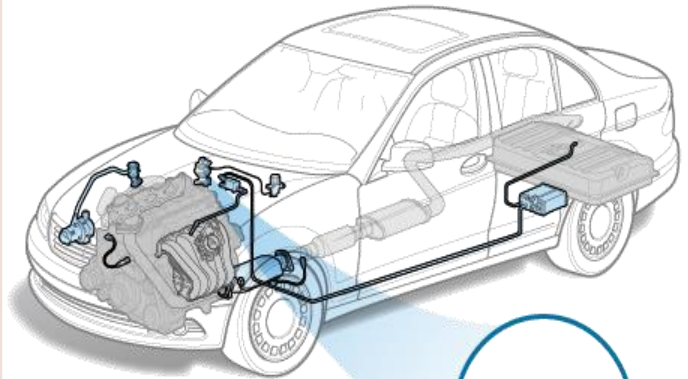

The variables measured can include:

- EGR pressure
- Exhaust gas temperature
- EGR Position

...EXHAUST GAS RECIRCULATION (EGR)

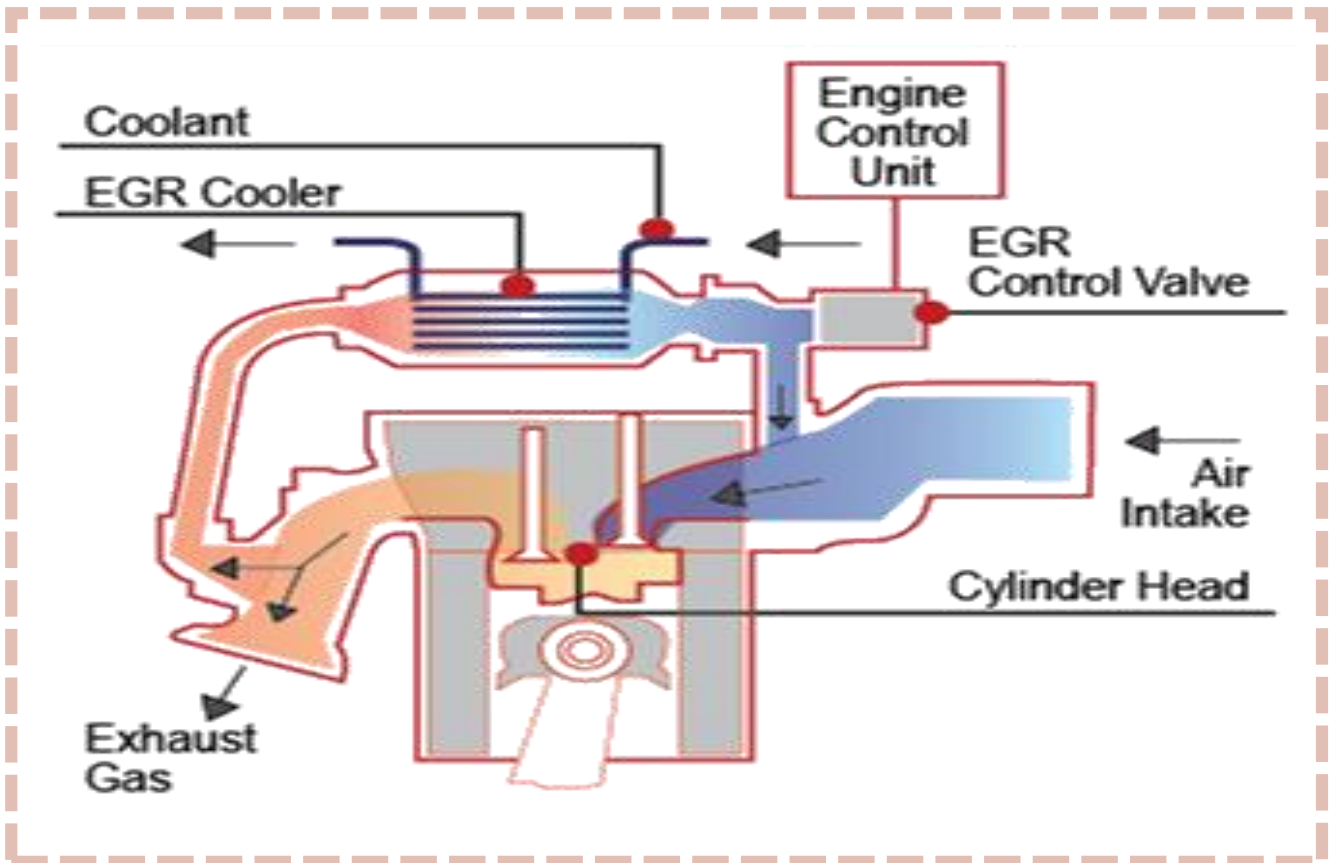

- EGR valve controls a small passageway between the intake and exhaust manifolds
- Oxide of Nitrogen (NO_x) is produced as a by-product of combustion

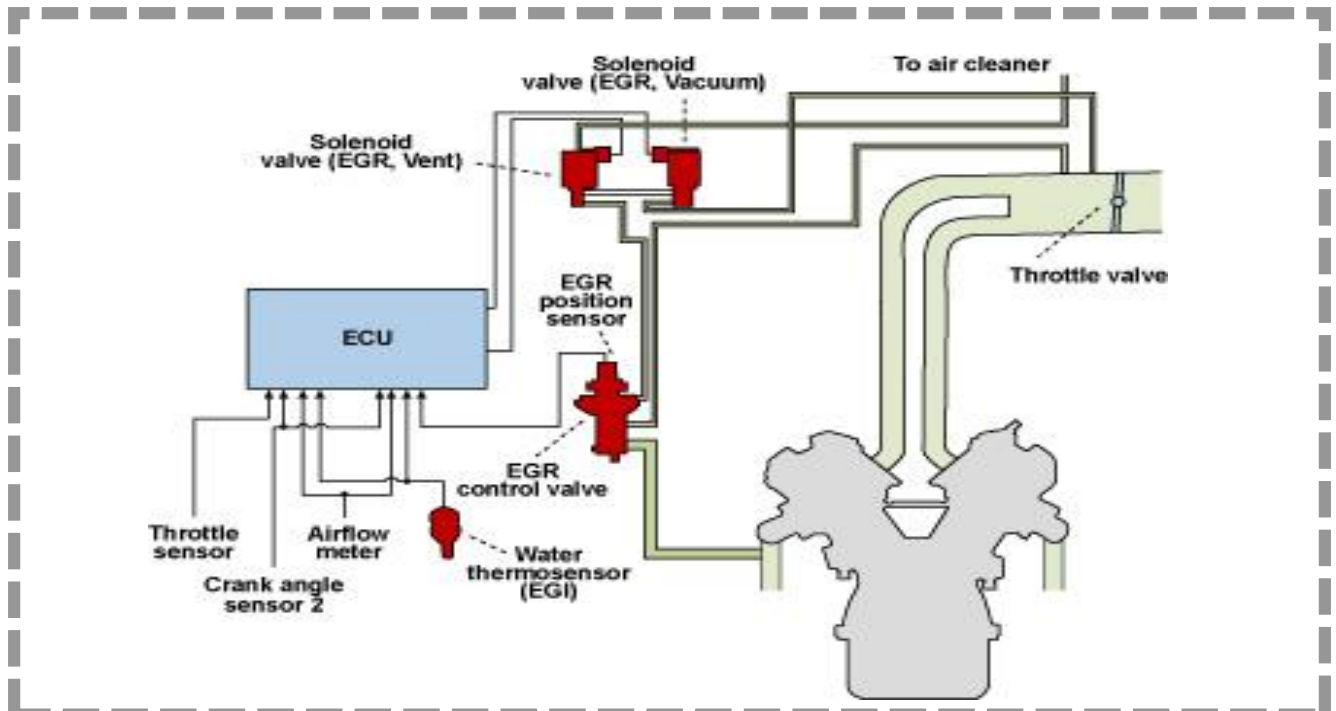

The engine's computer regulates EGR flow by opening and closing the valve as needed.

The ECU now has control over this valve and monitors several inputs to determine the amount and timing of operation.

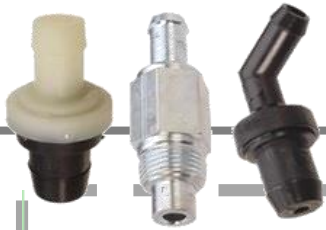

POSITIVE CRANKCASE VENTILATION (PCV)

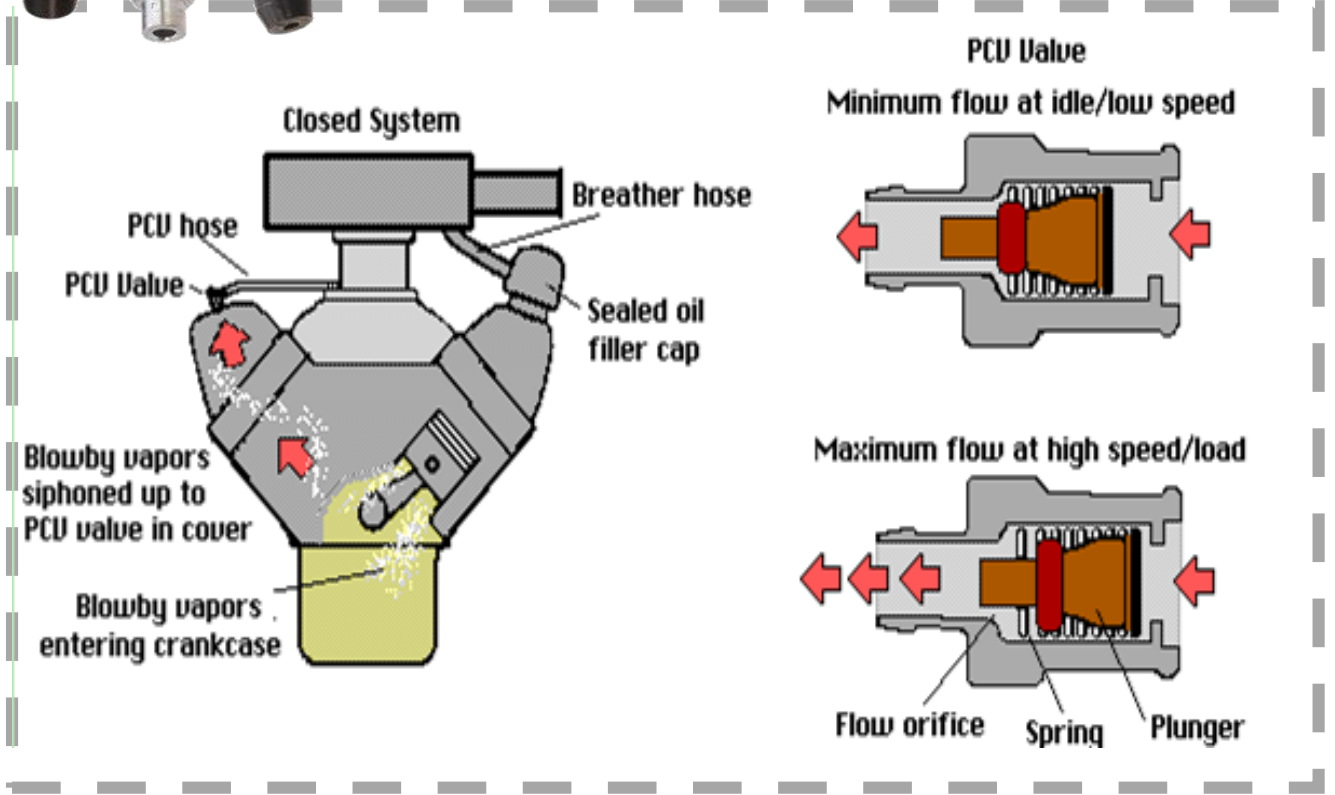

PCV System

PCV Valve Design & Operation

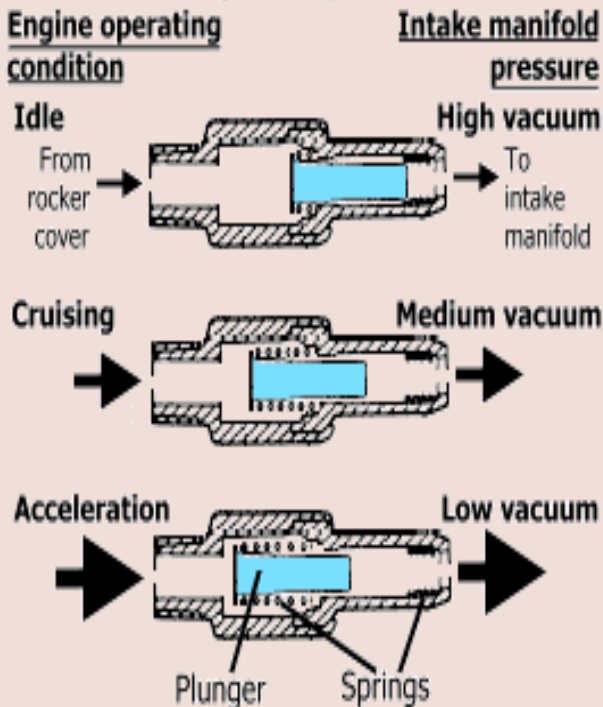

- To reduce the pressure in crankcase due to blow-by gases.
- High pressure in crankcase potential damage:
 - Oil contamination
 - Blow crankcase seal
 - Leakage at the gasket
 - Engine oil sludge
- Control mechanism that directs partially burned gases from the crankcase of the engine to the combustion chamber.
- Because of the regular air movement, the system is kept dry.
- The PCV valve returns partially burned gases from the crankcase to the engine.

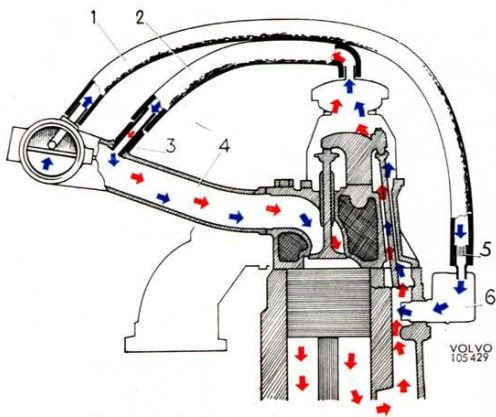

Fig. 2-12. Positive crankcase ventilation

- | | |
|------------------------------|----------------|
| 1. Hose for fresh air supply | 4. Inlet duct |
| 2. Hose for crankcase gases | 5. Flame guard |
| 3. Nipple | 6. Oil trap |

PCV System Components :

- i. PCV Valve
- ii. PCV purge hose
- iii. Breather hose

- Manifold vacuum is also used to suck crankcase vapours back into the intake manifold in this configuration.
- Blowing-by production is typically highest during high-load operations and lowest during idle and light-load operations.

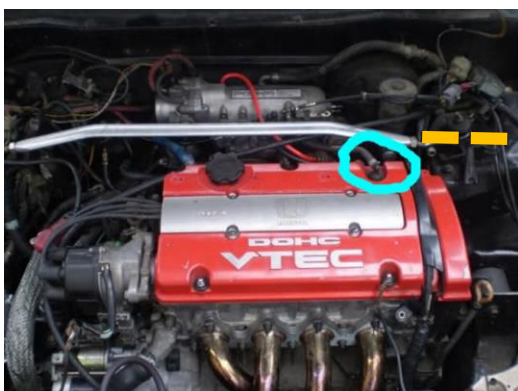
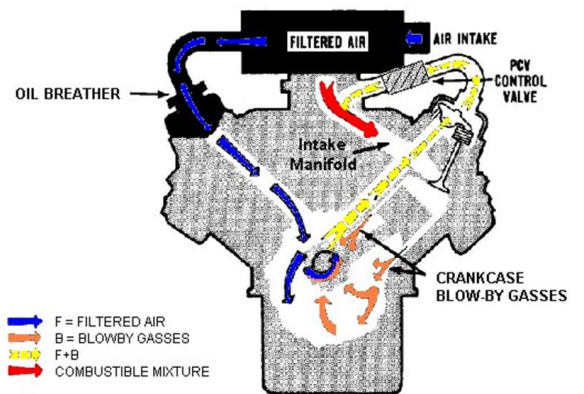
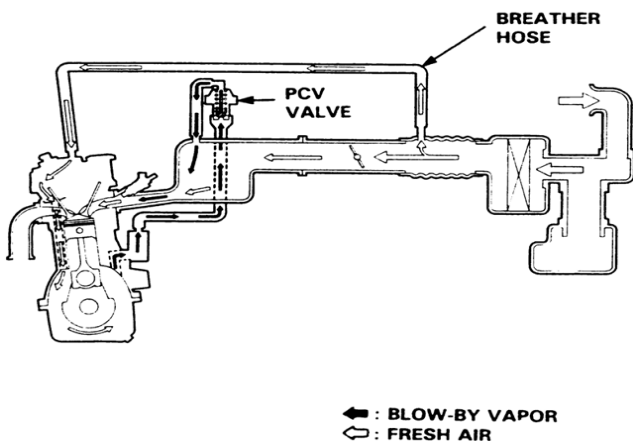
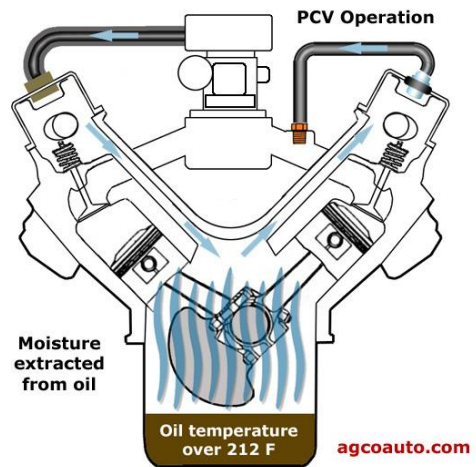

EVAPORATION CONTROL SYSTEM (EVAP)

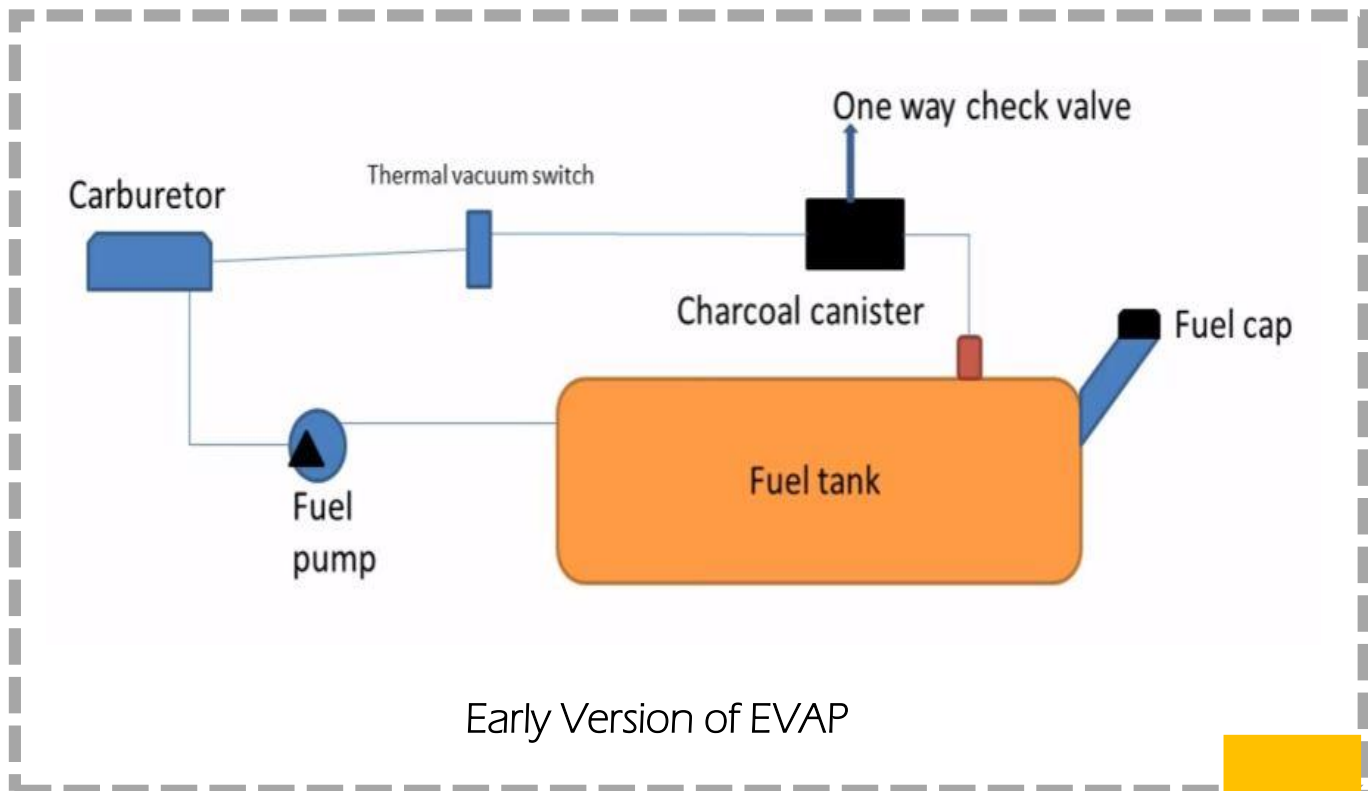
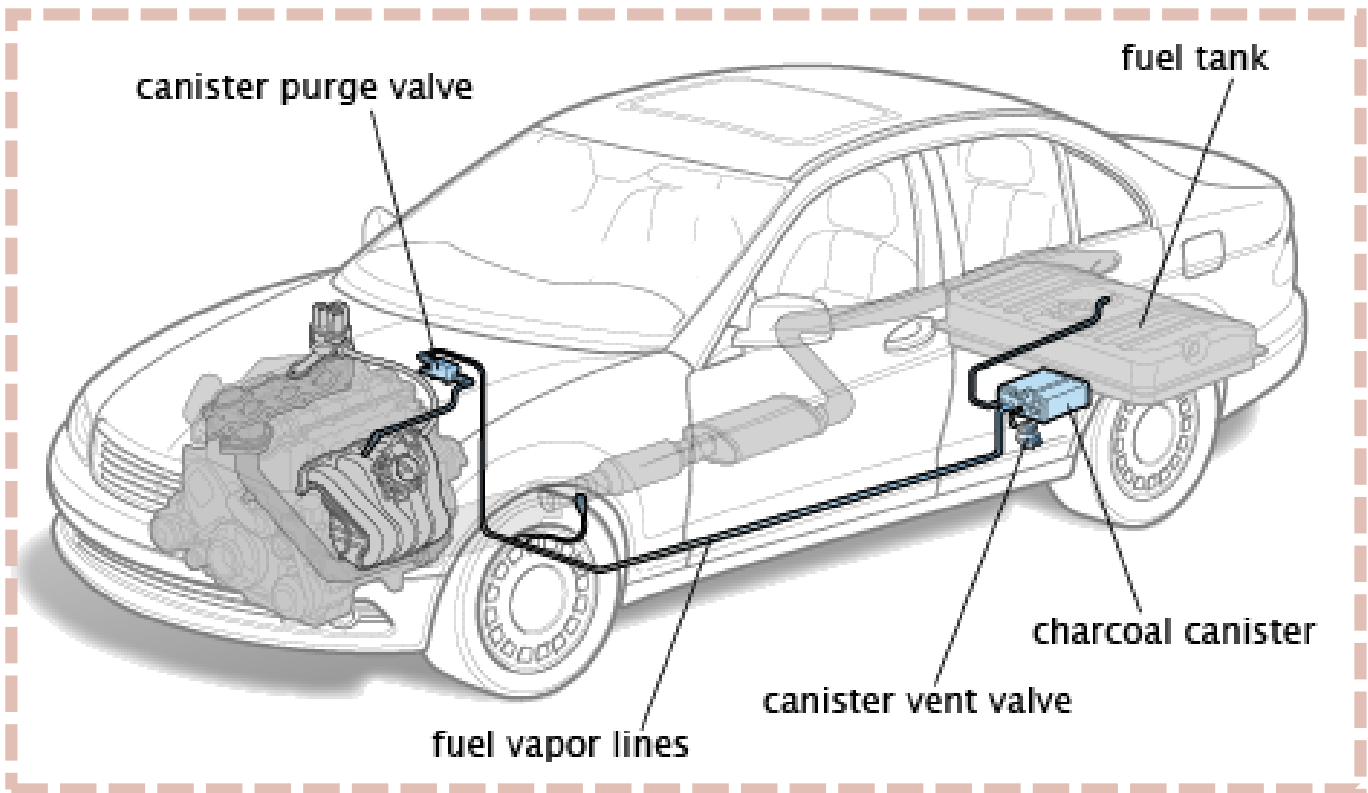

EVAPORATION EMISSION CONTROL SYSTEM (EVAP)

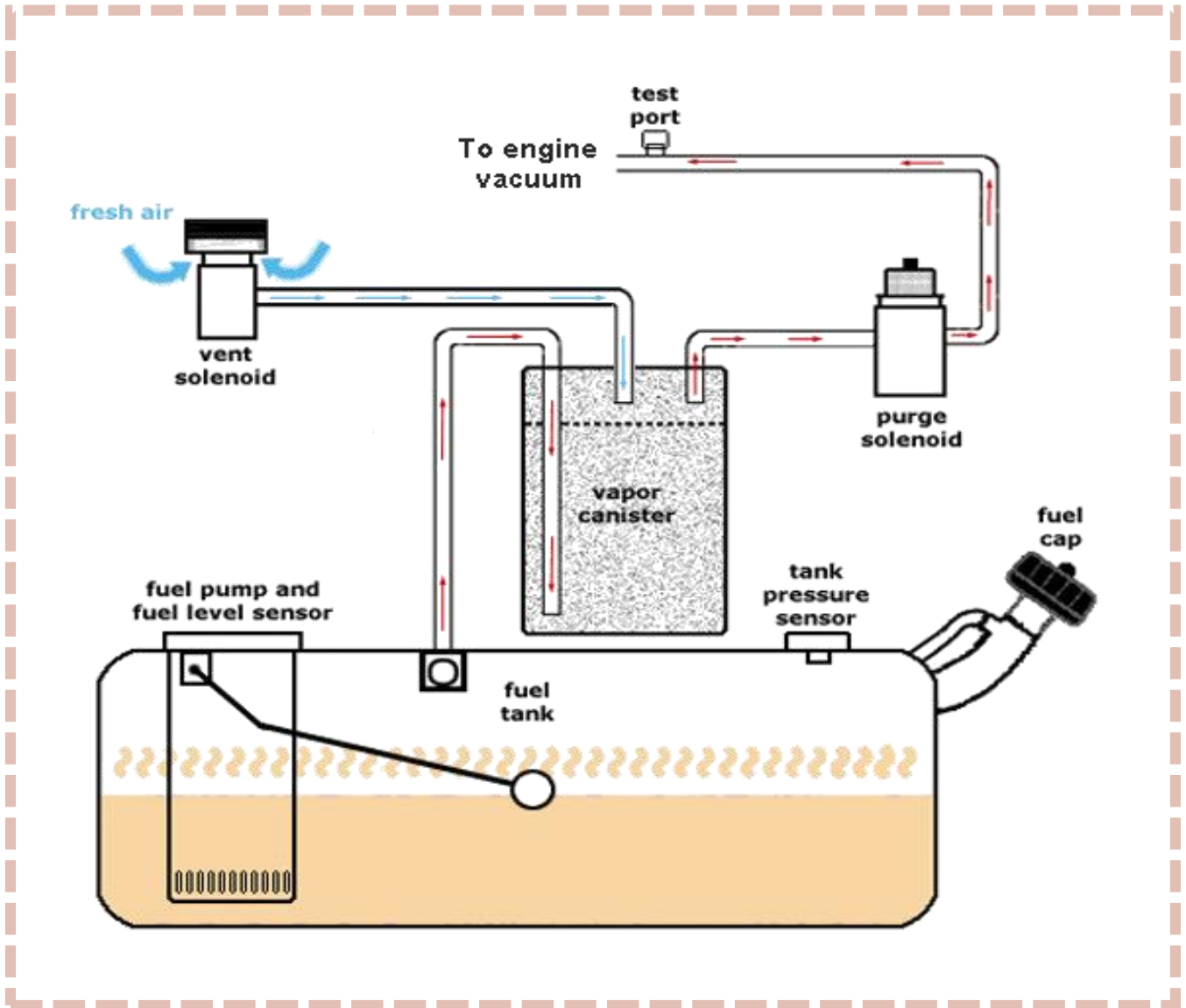

EVAP System

- Over time, the gasoline in the fuel tank evaporates, releasing volatile organic chemicals into the air
- EVAP - collects, removes and disposes of the vapors before they can escape into the atmosphere or enter into the vehicle compartment
- Although the EVAP system normally does not require maintenance, malfunctions can cause the Check Engine light to illuminate and prevent a vehicle from passing an OBD II plug-in emissions test.

PRESSURE SENSOR

- Monitors EVAP system vacuum

FUEL CAP

- Seals fuel system
- Allows for refueling

FUEL TANK

- Stores the liquid fuel

EVAP Components

PURGE VALVE

- The PCM opens this valve to allow the engine to pull gasoline vapours from the charcoal canister
- When the engine is at operating temperature, it does this.
- The charcoal will become saturated with fuel if the purge valve is not used.
- Used in conjunction with a pressure sensor to check for potential leaks in the system.
- Normally closed valve
 - Opens when power is applied

VENT VALVE

- Allows air in the fuel tank to be displaced when the tank is filled with fuel
- Normally open valve
 - Closes when power is applied

CHARCOAL CANISTER

- As fuel vapours evaporate from the tank, absorbent charcoal inside the canister catches them.

Modes of EVAP System

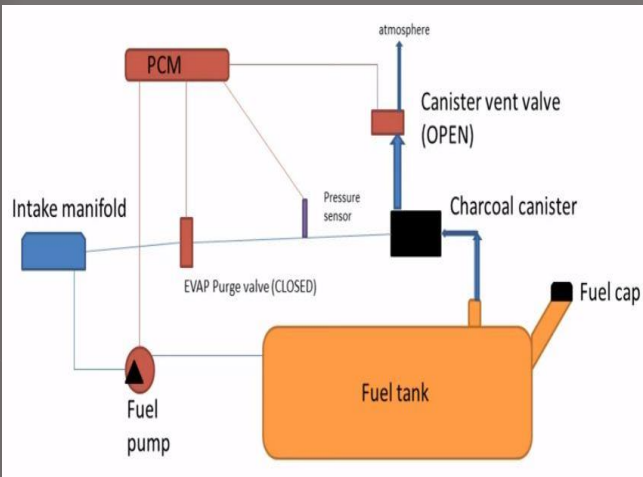

- The vehicle has been turned off
- Allows for air to escape fuel tank due to thermal expansion of fuel as well as refueling
- System opens to atmospheric pressure
- No power is supplied to components
- Vent valve is opened
- Purge valve is closed

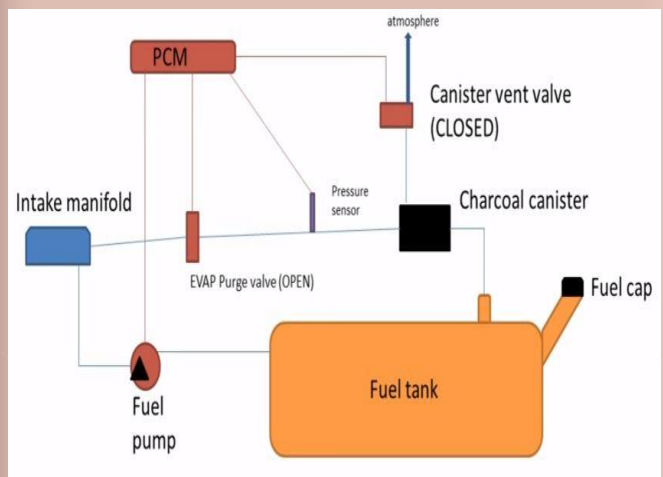

- Purge valve is opened
- Vent mode is closed
- Fuel vapours are drawn from the charcoal canister and burned in the engine



Mohd Fildza Ariffin ▶ **Persona/Gen2 Parts & Accesories Traders Group**

45 mins · 🗣️

salam smua, nak tumpang tanya ni...

saya ada masalah skit dgn kreta saya... bila saya isi mnyk kereta... mnyak asyik tendang kluar... mcam2 cara dah saya buat... tpi perkara sama tetap brulang... boleh king2 dlam ni bagi pncerahan?

trima kasi 😊



SECONDARY AIR INJECTION

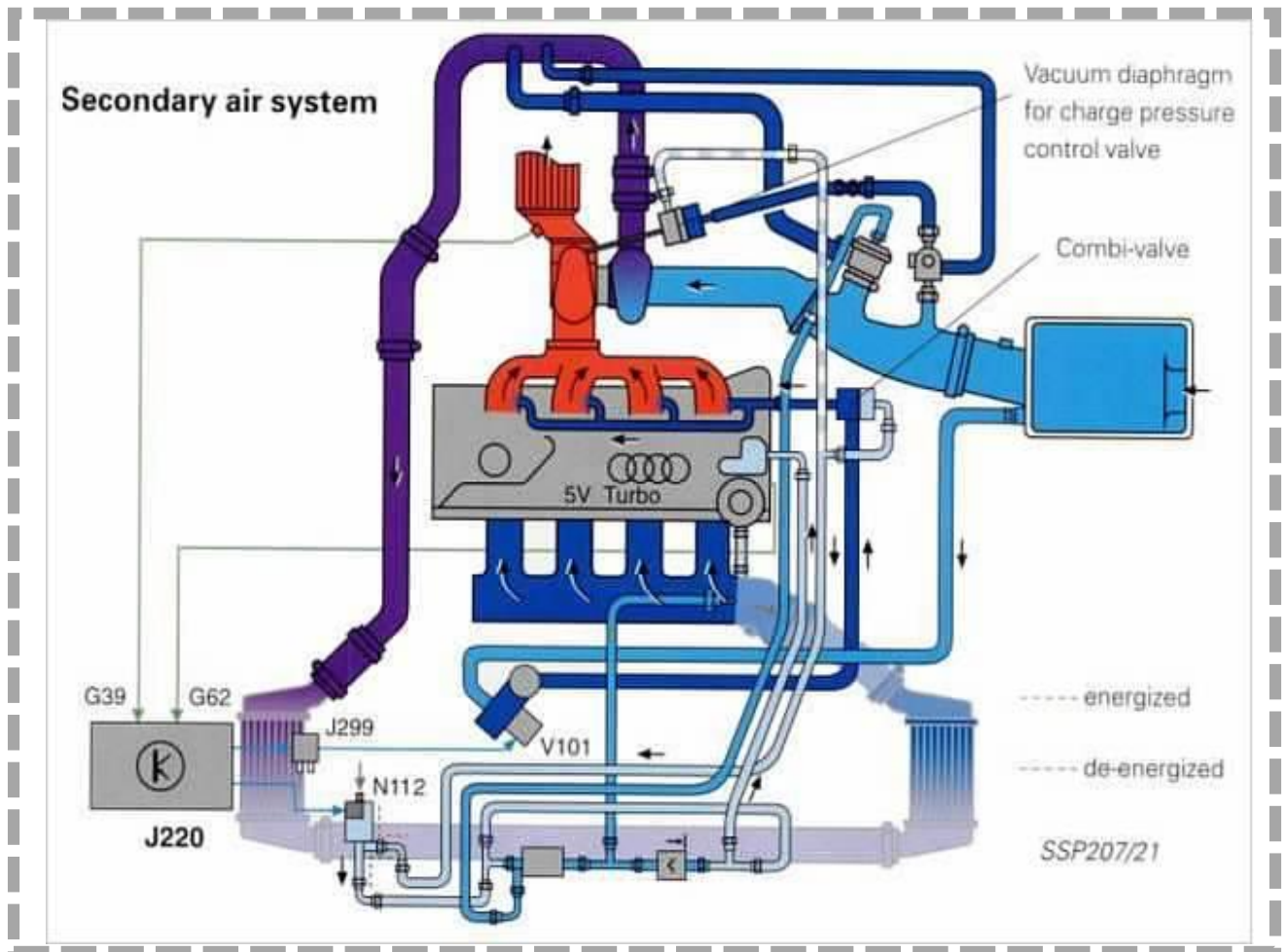

Secondary Air Injection System

- Outside air is injected into the exhaust stream by secondary air injection systems, allowing unburned fuel to be burnt.
- A belt-driven air pump was used in early air systems. The vacuum formed by an exhaust pulse is used in newer aspirated air systems to pull air into the pipe. Air is pumped using an electric motor in the most recent systems.

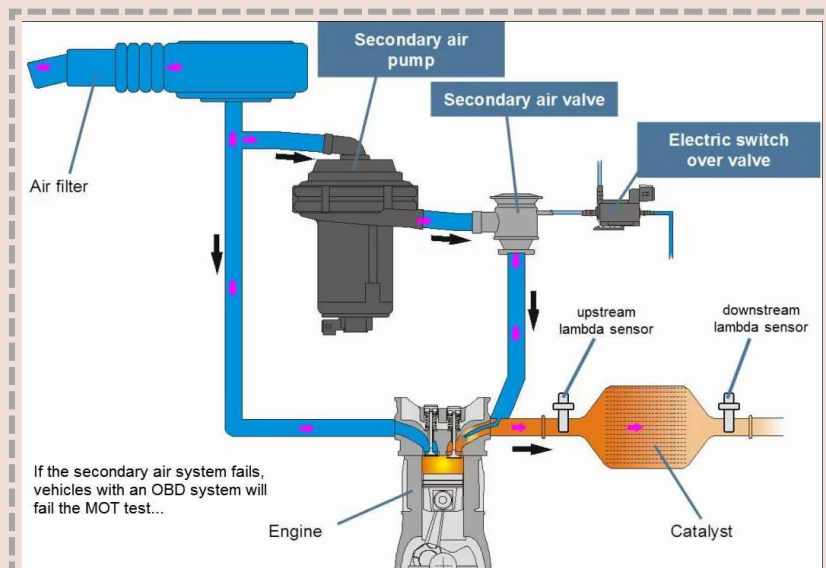

QUESTION CHAPTER 3

1. Identify the types of Emission Control Systems in vehicles and explain the function for each system.

- **Catalytic Converter** –
To reduce hydrocarbon and toxic gases in an exhaust pipe.
- **Exhaust Gas Recirculation System (EGR)** –
Allows burnt gases to enter the engine intake manifold, reducing NOx emissions.
- **Positive Crankcase Ventilation System (PCV)** –
Blow-by gases are drawn into the intake manifold by engine vacuum and reburned in the combustion chamber.
- **Air Injection System** –
To minimise HC/CO, fresh air is sent into the exhaust ports or catalytic converter.
- **Evaporative Emission Control System (EVAP)** –
 - Prevents the atmosphere from being contaminated by hazardous fuel system vapours.

2. Describe the function of Catalytic Converter in vehicle.

- The catalyst aids in the conversion of carbon monoxide to carbon dioxide
- It breaks down hydrocarbons into carbon dioxide, water, and nitrogen, as well as oxygen and nitrogen

3. Provide a list of the poisonous gases in exhaust system.

- a. Carbon Monoxide (CO)
- b. Hydrocarbon (HC)
- c. Particular Matter (PM)
- d. Sulphur Oxide (SO_x)
- e. Nitrogen Oxide (NO_x)

4. Identify the effects of exhaust emission pollutants to human health

- a. Central nervous system and heart toxicity
- b. Effects on a pregnant woman's baby are severe
- c. Dizziness and headaches
- d. There are issues with delivering oxygen to various bodily areas that could be life-threatening
- e. Irritation of the eyes in general
- f. The respiratory system is irritated
- g. Breathing problems

REFERENCES

1. Erjavec J. and Thompson R. (2019), *Automotive Technology: A System Approach*, 7th Edition, Cengage Delmar Learning.
2. Duffy J. E. (2017), *Modern Automotive Technology*, 9th Edition, The Goodheart- Willcox Publisher.
3. Halderman J. D. (2019), *Automotive Technology: Principles, Diagnosis, and Service*, 6th Edition, Pearson Education.

AUTOMOTIVE
TECHNOLOGY

e ISBN 978-967-2897-38-5



Terbitan

