

SULIT



**KEMENTERIAN PENDIDIKAN TINGGI
JABATAN PENDIDIKAN POLITEKNIK DAN KOLEJ KOMUNITI**

**BAHAGIAN PEPERIKSAAN DAN PENILAIAN
JABATAN PENDIDIKAN POLITEKNIK DAN KOLEJ KOMUNITI
KEMENTERIAN PENDIDIKAN TINGGI**

JABATAN KEJURUTERAAN MEKANIKAL

PEPERIKSAAN AKHIR

SESI I : 2025/2026

DJJ20263: ELECTRICAL AND ELECTRONIC TECHNOLOGY

TARIKH : 10 DISEMBER 2025

MASA : 11.30 PAGI - 01.30 PETANG (2 JAM)

Kertas ini mengandungi **SEMBILAN (9)** halaman bercetak.

Struktur (4 soalan)

Dokumen sokongan yang disertakan : Formula

JANGAN BUKA KERTAS SOALAN INI SEHINGGA DIARAHKAN

(CLO yang tertera hanya sebagai rujukan)

SULIT

INSTRUCTION:

This section consists of **FOUR (4)** structured questions. Answer **ALL** questions.

ARAHAN:

Bahagian ini mengandungi EMPAT (4) soalan berstruktur. Jawab SEMUA soalan.

QUESTION 1**SOALAN 1**

CLO1

- (a) List **FOUR (4)** factors that influence the value of resistance.

Senaraikan EMPAT (4) faktor mempengaruhi nilai rintangan.

[4 marks]

[4 markah]

CLO1

- (b) Compare the 3 Φ and 1 Φ systems in terms of colour coded cables, waveforms and applications.

Bandingkan sistem 3 Φ dan 1 Φ dari segi warna kod kabel, gambarajah gelombang dan aplikasi.

[6 marks]

[6 markah]

CLO1

(c) Refer to the Figure 1(c) below and solve the following:

Rujuk Rajah 1 (c) di bawah dan selesaikan yang berikut :

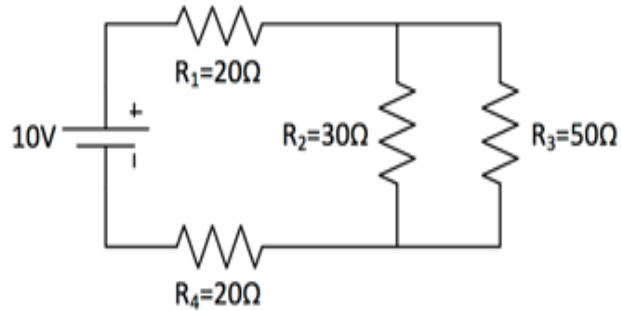

Figure 1(c) / Rajah 1(c)

- i. Total resistance, R_T
Jumlah rintangan, R_T [5 marks]
[5 markah]
- ii. Total current, I_T
Jumlah Arus, I_T [3 marks]
[3 markah]
- iii. Current at resistor R_2 , I_{R2}
Arus pada perintang R_2 , I_{R2} [3 marks]
[3 markah]
- iv. Current at resistor R_3 , I_{R3}
Arus pada perintang R_3 , I_{R3} [2 marks]
[2 markah]
- v. Voltage drop at R_4 ,
Voltan jatuh pada R_4 [2 marks]
[2 markah]

QUESTION 2

SOALAN 2

- CLO1 (a) List **FOUR (4)** factors that affect the electromagnetic strength.
Senaraikan EMPAT (4) faktor mempengaruhi kekuatan elektromagnet
[4 marks]
[4 markah]
- CLO1 (b) Visualize the magnetic field when two currents carrying conductors are put nearby.
Lukiskan medan magnet apabila dua konduktor berarus diletakkan berdekatan.
[8 marks]
[8 markah]
- CLO1 (c) A loop shaped of a mild steel has length of 40 cm and cross-sectional area of 2 cm². It is wound with 1000 turns and 4A current flows through it. Relative permeability $\mu_r = 1200$. Calculate the following:
Sebuah gelung berbentuk litar terbuat daripada besi lembut mempunyai panjang 40 cm dan luas keratan rentas 2 cm². Gelung tersebut dililit sebanyak 1000 lilitan dan arus 4A mengalir melaluinya. Kebolehtelapan relatif bahan ialah $\mu_r = 1200$. Hitungkan nilai bagi perkara berikut :
- i. Magnetomotive force, F_m
Daya gerak magnet, F_m
[2 marks]
[2 markah]
- ii. Magnetic field strength, H
Kekuatan medan magnet, H
[2 marks]
[2 markah]

- iii. Absolute permeability, μ
Kebolehtelapan mutlak, μ
- [2 marks]
[2 markah]
- iv. Flux density, B
Ketumpatan fluks magnet, B
- [2 marks]
[2 markah]
- v. The value of flux, Φ
Nilai fluks magnet, Φ
- [2 marks]
[2 markah]
- vi. The reluctance, S
Engganan magnet, S
- [3 marks]
[3 markah]

QUESTION 3

SOALAN 3

- CLO1 (a) State **TWO (2) differences** between a DC motor and an AC motor.
Nyatakan DUA (2) perbezaan antara motor AT dan motor AU.
- [4 marks]
[4 markah]
- CLO1 (b) Explain how a DC motor converts electrical energy into mechanical energy.
Terangkan bagaimana motor AT menukarkan tenaga elektrik kepada tenaga mekanikal.
- [6 marks]
[6 markah]
- CLO1 (c) A 4-pole, 50 Hz three-phase induction motor is operating under the following conditions, calculate:
Sebuah motor peraruh 4-kutub, 50 Hz beroperasi di bawah keadaan berikut, kirakan:
- i. The synchronous speed, N_s
Kelajuan segerak, N_s
- [3 marks]
[3 markah]
- ii. The percentage slip if the rotor runs at 1440 rpm under load
Peratus gelinciran sekiranya rotor bergerak dengan kelajuan 1440rpm di bawah beban
- [3 marks]
[3 markah]
- iii. The rotor frequency at this operating point.
Frekuensi rotor pada titik operasi ini
- [2 marks]
[2 markah]

- iv. The new rotor speed N_r if the slip increases to 6%,
Nilai kelajuan rotor yang baru sekiranya gelinciran meningkat kepada 6%,
[3 marks]
[3 markah]
- v. The new stator frequency
Frekuensi stator yang baru.
[4 marks]
[4 markah]

QUESTION 4**SOALAN 4**

CLO1

(a) Define an open-loop and closed-loop control system with **ONE (1)** example.

*Takrifkan gegelung terbuka dan gegelung tertutup system kawalan dan **SATU (1)** contoh.*

[4 marks]

[4 markah]

CLO1

(b) i. Explain **ONE (1)** type of sensors and **ONE (1)** application.

*Terangkan **SATU (1)** jenis pengesan dan **SATU (1)** aplilkasi.*

[4 marks]

[4 markah]

ii. Explain the working principle of transducers and its application.

Terangkan prinsip kerja transducer dan aplikasinya.

[4 marks]

[4 markah]

CLO1

(c)

- i. The Figure 4(c) below shows a logic circuit and its incomplete truth table. Complete the Truth Table below.

Rajah 4(c) di bawah menunjukkan litar logik dan jadual kebenaran yang belum lengkap. Lengkapkan Jadual Kebenaran tersebut.

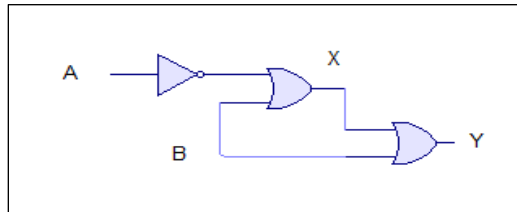

Figure 4 (c) / *Rajah 4 (c)*

A	B	X	Y
0	0		
0	1		
1	0		
1	1		

[4 marks]

[4 markah]

CLO1

- ii. The output Y of the logic circuit is given by the Boolean expression (eq. 4.1). Construct the truth table for the expression and construct the logic circuit diagram.

Keluaran Y untuk litar logik diberi oleh pernyataan Boolean (eq. 4.1). Lukiskan jadual kebenaran untuk pernyataan tersebut dan binakan rajah litar logik.

$$Y = (A + B) \bullet \bar{C} \dots\dots\dots \text{eq 4.1}$$

[9 marks]

[9 markah]

SOALAN TAMAT

**DJJ20263 – ELECTRICAL AND ELECTRONIC TECHNOLOGY
FORMULA**

Introduction to Electrical and Electronic	Electromagnetism and Electrostatic
<p>$V = IR$ $P = IV$ $E = Pt$ $Q = CV$</p> <p align="center"><u>Series Circuit</u></p> $R_T = R_1 + R_2 + R_3 + \dots R_n$ $V_T = V_1 + V_2 + V_3 + \dots V_n$ $I_T = I_1 = I_2 = I_3 = \dots = I_n$ <p align="center">Voltage Divider Law</p> $V_X = \left(\frac{R_X}{R_T}\right) V_T$ <p align="center"><u>Parallel Circuit</u></p> $\frac{1}{R_T} = \frac{1}{R_1} + \frac{1}{R_2} + \frac{1}{R_3} + \dots \frac{1}{R_n} \text{ or}$ $R_T = \frac{R_1 R_2 R_3}{R_2 R_3 + R_1 R_3 + R_1 R_2}$ $V_T = V_1 = V_2 = V_3 = \dots = V_n$ $I_T = I_1 + I_2 + I_3 + \dots I_n$ <p align="center">Current Divider Law</p> $I_x = \left(\frac{R_T}{R_x}\right) I_T$	<p align="center"><u>Electromagnetism</u></p> $\Phi = B \times A \quad B = \frac{\Phi}{A} \quad B = \mu H$ $F_M = NI \quad H = \frac{F_M}{l}$ $\mu = \mu_0 \mu_r \quad \mu = \frac{B}{H} \quad \mu_0 \mu_r = \frac{B}{H}$ $S = \frac{F_M}{\Phi} \quad S = \frac{l}{\mu H} \quad S = \frac{l}{\mu_0 \mu_r A}$ <p align="center"><u>Transformer</u></p> $\frac{V_P}{V_S} = \frac{N_P}{N_S} = \frac{I_S}{I_P}$ $E_P = 4.44fN_P\Phi \quad E_S = 4.44fN_S\Phi$ <p align="center"><u>Inductor</u></p> $E = \frac{1}{2} LI^2$ <p align="center">Series inductor</p> $L_T = L_1 + L_2 + L_3 + \dots L_n$ <p align="center">Parallel inductor</p> $\frac{1}{L_T} = \frac{1}{L_1} + \frac{1}{L_2} + \frac{1}{L_3} + \dots \frac{1}{L_n}$ <p align="center"><u>Capacitor</u></p> $E = \frac{1}{2} QV$ <p align="center">Series capacitor</p> $\frac{1}{C_T} = \frac{1}{C_1} + \frac{1}{C_2} + \frac{1}{C_3} + \dots \frac{1}{C_n}$ <p align="center">Parallel capacitor</p> $C_T = C_1 + C_2 + C_3 + \dots C_n$
Motor and Generator	Automation Control System
$N_S = \frac{120f}{P} \quad N_r = N_S (1 - S)$ $S = \frac{N_S - N_r}{N_S} \quad \%S = \frac{N_S - N_r}{N_S} \times 100\%$ $f_r = S \times f$ $f = f_r + f_s$	<p align="center"><u>Boolean Expression</u></p> <p>AND Gate: $Y=A \cdot B$ (A AND B)</p> <p>OR Gate: $Y=A+B$ (A OR B)</p> <p>NOT Gate: $Y=A$ (NOT A)</p> <p>NAND Gate: $Y=A \cdot B$ (NOT (A AND B))</p> <p>NOR Gate: $Y=A+B$ (NOT (A OR B))</p> <p>XOR Gate: $Y=A \oplus B$ (A XOR B)</p> <p>XNOR Gate: $Y=A \oplus B$ (NOT (A XOR B))</p>