

SULIT



**KEMENTERIAN PENDIDIKAN TINGGI
JABATAN PENDIDIKAN POLITEKNIK DAN KOLEJ KOMUNITI**

**BAHAGIAN PEPERIKSAAN DAN PENILAIAN
JABATAN PENDIDIKAN POLITEKNIK DAN KOLEJ KOMUNITI
KEMENTERIAN PENDIDIKAN TINGGI**

JABATAN KEJURUTERAAN ELEKTRIK

PEPERIKSAAN AKHIR

SESI I : 2025/2026

DET20033: ELECTRICAL CIRCUITS

TARIKH : 29 NOVEMBER 2025

MASA : 8.30 PAGI – 10.30 PAGI (2 JAM)

Kertas ini mengandungi **TUJUH (7)** halaman bercetak.
Bahagian A: Struktur (4 soalan)
Bahagian B: Esei (1 soalan)

Dokumen sokongan yang disertakan : Formula

JANGAN BUKA KERTAS SOALAN INI SEHINGGA DIARAHKAN

(CLO yang tertera hanya sebagai rujukan)

SULIT

SECTION A : 80 MARKS
BAHAGIAN A : 80 MARKAH

INSTRUCTION:

This section consists of **FOUR (4)** subjective questions. Answer **ALL** questions.

ARAHAN :

Bahagian ini mengandungi EMPAT (4) soalan subjektif. Jawab SEMUA soalan.

QUESTION 1

SOALAN 1

- CLO1 (a) List **FOUR (4)** sources of Alternating Current (AC).
Senaraikan EMPAT (4) sumber Arus Ulang Alik (AU).
- [4 marks]
[4 markah]
- CLO1 (b) Using the diagram of a simple AC generator, discuss Faraday's Law and Lenz's Law in the generation of alternating current.
Menggunakan gambarajah penjana AU ringkas, bincangkan Hukum Faraday dan Hukum Lenz dalam penghasilan arus ulang alik.
- [6 marks]
[6 markah]
- CLO1 (c) An alternating voltage equation is given by $V = 215 \sin(100\pi t + 0.25)V$. Calculate the value of amplitude, frequency, phase angle in degree and the voltage when $t = 5.5\text{ms}$.
Satu persamaan voltan ulang alik diberi oleh $V = 215 \sin(100\pi t + 0.25) V$. Kirakan nilai amplitud, frekuensi, sudut fasa dalam darjah dan voltan apabila masa, $t = 5.5\text{ms}$
- [10 marks]
[10 markah]

QUESTION 2**SOALAN 2**

- CLO1 (a) With the aid of a waveform diagram, explain the relationship between current and voltage for a purely resistive and a purely inductive in an alternating current (AC) circuit.
- Dengan bantuan gambarajah gelombang, jelaskan hubungan antara arus dan voltan untuk rintangan tulen dan induktif tulen dalam litar arus ulang alik (AU).*
- [5 marks]
[5 markah]
- CLO1 (b) Explain the alternating current (AC) circuit's power factor.
- Terangkan faktor kuasa dalam litar arus ulang alik (AU).*
- [5 marks]
[5 markah]
- CLO1 (c) Based on Figure A2 (c), a series resonance circuit consisting of a resistor of 25Ω , a capacitor of 120nF and an inductor of 100mH is connected across a sinusoidal supply voltage which has a constant output of 200V at all frequencies. Calculate the resonant frequency, the current at resonance, the voltage across the inductor and capacitor at resonance and the quality factor of the circuit.
- Berdasarkan rajah A2 (c), satu litar resonans sesiri yang terdiri daripada perintang 25Ω , pemuat $10\mu\text{F}$ dan pearuh 100mH disambungkan ke voltan bekalan sinusoidal yang mempunyai keluaran tetap 200V pada semua frekuensi. Kirakan frekuensi salun, arus ketika salun, voltan merintang pearuh dan pemuat ketika salun dan factor kualiti dalam litar.*
- [10 marks]
[10 markah]

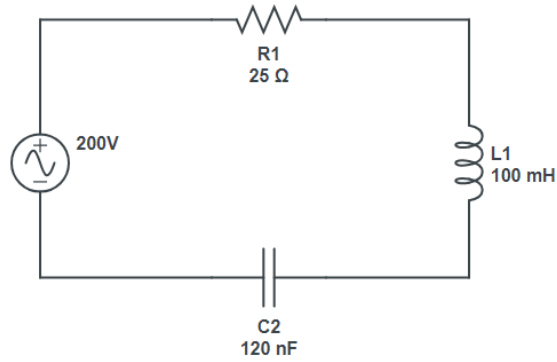

Figure A2 (c) / Rajah A2 (c)

QUESTION 3**SOALAN 3**

- CLO1 (a) List **FOUR (4)** types of transformer.
Senaraikan EMPAT (4) jenis transformer.
- [4 marks]
[4 markah]
- CLO1 (b) Explain **THREE (3)** main parts of a transformer and its functions.
Terangkan TIGA (3) bahagian utama sebuah transformer dan fungsinya.
- [6 marks]
[6 markah]
- CLO1 (c) Referring to the figure A3 (c), calculate the value of primary voltage (V_P) secondary voltage (V_s), primary current (I_P) and secondary current (I_s)
- Merujuk rajah A3(c), kirakan nilai voltan primer (V_P), voltan sekunder (V_s), arus primer (I_P) dan arus sekunder (I_s)*

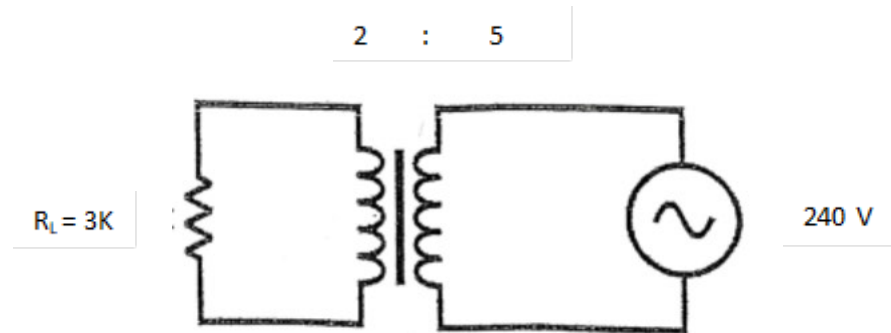

Figure A3(c)/ Rajah A3(c)

[10 marks]

[10 markah]

QUESTION 4

SOALAN 4

- CLO1 (a) Express the phenomenon of resonance.
Terangkan fenomena resonans.

[5 marks]

[5 markah]

- CLO1 (b) Discuss the DELTA connection in a three-phase system using appropriate circuit diagram.
DELTA dikenali sebagai sambungan sarang. Bincangkan sambungan DELTA di dalam sistem tiga fasa dengan menggunakan gambar rajah litar yang sesuai.

[5 marks]

[5 markah]

CLO1

- (c) A three-phase load are connected to 415V, 50Hz voltage supply. Each phase consists of 20Ω resistor which connected in series with 3mH inductor in Delta Connection. Calculate the phase and line current.

Satu beban tiga fasa disambungkan dengan 415V, 50Hz bekalan voltan. Setiap fasa mengandungi 20Ω perintang yang disambungkan secara siri dengan 3mH induktor dalam Sambungan Delta. Kirakan arus fasa dan arus talian

[10 marks]

[10 markah]

SECTION B : 20 MARKS***BAHAGIAN B :20 MARKAH*****INSTRUCTION:**

This section consists of **ONE (1)** essay question. Answer the question.

ARAHAN:

*Bahagian ini mengandungi **SATU (1)** soalan esei. Jawab soalan tersebut.*

QUESTION 1***SOALAN 1***

CLO1

A coil with an inductance of 314.8mH and resistance of 60Ω is connected in parallel with a 15μF capacitor across 200V, 50Hz supply. Calculate the current flowing through the capacitor, the current in the coil, the circuit impedance, the supply current and the power consumed.

Satu gegelung yang mempunyai kearuhan 314.mH dan rintangan 60Ω disambungkan secara selari dengan 15μF kapasitor merentasi bekalan 200V, 50Hz. Kira arus di dalam kapasitor, arus di dalam gelung, galangan litar, arus bekalan dan kuasa yang telah digunakan.

[20 marks]

[20 markah]

SOALAN TAMAT

SENARAI FORMULA

$V_P = \sqrt{2} \times V_{rms}$	$v(t) = V_P \sin(\omega t \pm \theta)$	$X_L = 2\pi fL$
$I_P = \sqrt{2} \times I_{rms}$	$i(t) = I_P \sin(\omega t \pm \theta)$	$X_C = \frac{1}{2\pi fC}$
$V_{PP} = 2V_P$	$Z_T = \sqrt{R^2 + X_{eq}^2}$ if $X_L > X_C$; $X_{eq} = X_L - X_C$ if $X_C > X_L$; $X_{eq} = X_C - X_L$	
$I_{PP} = 2I_P$	$S = IV$ $S = I^2 Z$	$I_T = \frac{V_S}{Z_T}$
$V_{rms} = \frac{V_P}{\sqrt{2}}$	$P = IV \cos \theta$ $P = I^2 R$	$\theta = \cos^{-1} PF$
$I_{rms} = \frac{I_P}{\sqrt{2}}$	$Q = IV \sin \theta$ $Q = I^2 X_C - X_L $	$\theta = \tan^{-1} \left(\frac{X_C - X_L}{R} \right)$ $\theta = \tan^{-1} \left(\frac{V_C - V_L}{V_S} \right)$
$V_{ave} = \frac{2V_P}{\pi}$	$I_T = \sqrt{I_R^2 + (I_C - I_L)^2}$	$\cos \theta = \frac{R}{Z}$
$I_{ave} = \frac{2I_P}{\pi}$	$Z_T = \frac{V_S}{I_T}$	$V_R = IR$
$T = \frac{1}{f}$ $T = \frac{2\pi}{\omega}$	$\theta = \tan^{-1} \left(\frac{I_C - I_L}{I_R} \right)$	$V_L = IX_L$
$f = \frac{1}{T}$ $f = \frac{\omega}{2\pi}$	$f_r = \frac{1}{2\pi} \sqrt{\frac{1}{LC} - \frac{R^2}{L^2}}$	$V_C = IX_C$
$Z_T = \sqrt{R^2 + X_{eq}^2} = \sqrt{R^2 + 0} = R$		$BW = f_H - f_L = \frac{f_r}{Q}$
$I_T = \frac{V_S}{R}$	$f_L = f_r - \frac{BW}{2}$	$f_L = f_r + \frac{BW}{2}$

$$\theta = \cos^{-1} PF = \cos^{-1} 1 = 0^\circ$$

$$f_L = f_r + \frac{BW}{2}$$

$$\theta = \tan^{-1} \left(\frac{X_C - X_L}{R} \right) = \tan^{-1} \left(\frac{0}{R} \right) = 0^\circ$$

$$Q = \frac{X_L}{R} = \frac{f_r}{BW}$$

$$\theta = \tan^{-1} \left(\frac{V_C - V_L}{V_S} \right) = \tan^{-1} \left(\frac{0}{V_S} \right) = 0^\circ$$

$$\cos \theta = \frac{R}{Z} = \frac{R}{R} = 1$$

$$\eta = \frac{N_1}{N_2} = \frac{V_1}{V_2} = \frac{I_2}{I_1}$$

$$f_r = \frac{1}{2\pi\sqrt{LC}}$$

$$V_2 = \frac{N_2}{N_1} \times V_1$$

$$V_2 = \frac{P_2}{I_2}$$

$$Q = \frac{X_L}{R} = \frac{X_C}{R} = \frac{V_L}{V_S} = \frac{V_C}{V_S} = \frac{1}{R} \sqrt{\frac{L}{C}} = \frac{f_r}{BW}$$

$$V_1 = \frac{N_1}{N_2} \times V_2$$

$$V_1 = \frac{P_1}{I_1}$$

$$I_1 = \frac{N_2}{N_1} \times I_2$$

$$I_2 = \frac{V_2}{R_L}$$

$$S_1 = S_2$$

$$I_1 V_1 = I_2 V_2$$

$$Z_P = \sqrt{R^2 + X_{eq}^2}$$

$$\text{if } X_L > X_C; \quad X_{eq} = X_L - X_C$$

$$\text{if } X_C > X_L; \quad X_{eq} = X_C - X_L$$

$$P_1 = I_1 V_1$$

$$P_2 = I_2 V_2 \quad \text{or} \quad P_2 = I_2^2 R_L$$

$$P_1 = P_2$$

$$Z_P = \frac{V_P}{I_P}$$

$$V_L = V_{RY} = V_{YB} = V_{BR}$$

$$V_L = V_{RY} = V_{YB} = V_{BR}$$

$$S = 3 I_P V_P$$

$$V_L = \sqrt{3} V_P$$

$$V_L = V_P$$

$$S = \sqrt{3} I_L V_L$$

$$V_P = V_R = V_Y = V_B$$

$$V_P = V_L$$

$$P = 3 I_P V_P \cos \theta$$

$$V_P = \frac{V_L}{\sqrt{3}}$$

$$P = \sqrt{3} I_L V_L \cos \theta$$

$$I_P = \frac{V_P}{Z_P}$$

$$I_P = \frac{V_P}{Z_P}$$

$$I_P = I_L$$

$$I_P = \frac{I_L}{\sqrt{3}}$$

$$I_L = I_P$$

$$I_L = \sqrt{3} I_P$$