

# BUILDING SERVICES

VOLUME 1



Diploma in Architecture

Civil Engineering Department

Badariah binti Daud  
Wan Nadhirah binti Abd. Wahab  
Zarith Sofia binti Abu Zahri



# BUILDING SERVICES

VOLUME 1

Perpustakaan Negara Malaysia Cataloguing-in-Publication Data

Badariah Daud, 1983-  
BUILDING SERVICES. VOLUME 1 / Badariah binti Daud, Wan Nadhirah binti  
Abd. Wahab, Zarith Sofia binti Abu Zahri.

Mode of access: Internet  
eISBN 978-967-2897-22-4

1. Building management.
2. Bathrooms--Design and construction.
3. Public buildings--Restrooms--Design and construction.
4. Government publications--Malaysia.
5. Electronic books.

I. Wan Nadhirah Abd. Wahab, 1990-. II. Zarith Sofia Abu Zahri, 1984-.

III. Title.  
658.2

**Published by:**

Politeknik Port Dickson  
KM 14, Jalan Pantai, 71050, Si Rusa,  
Port Dickson, Negeri Sembilan

**NOVEMBER 2021**

**Copyright**

Each part of this publication may not be reproduced or distributed in any forms by any means or retrieval system without prior written permission.

**PATRON**

**En. Mohamad Isa bin Azhari**  
Director, Polytechnic Port Dickson

**ADVISORS**

**Dr. Nor Haniza binti Mohamad**  
Deputy Director (Academic), Polytechnic Port Dickson

**Pn. Ruslinda binti Abdullah**  
Head of Civil Engineering Department, Polytechnic Port Dickson

**EDITOR**

**Pn. Zarith Sofia binti Abu Zahri**  
Head of Architecture Programme, Polytechnic Port Dickson

**FACILITATOR**

**Pn. Siti Fatimah Tuzzahrah binti Hj. Abd Latif**

**WRITERS**

**Pn. Badariah binti Daud**  
**Pn. Wan Nadhirah binti Abd. Wahab**  
**Pn. Zarith Sofia binti Abu Zahri**

## ACKNOWLEDGEMENTS

We would like to convey our utmost gratitude to the Department of Polytechnic and Community College Education particularly the E-learning and Instructional Division (BIPD) for funding our e-book project.

We hereby declare that this module is our original work. To the best of our knowledge it contains no materials previously written or published by another person. However, if there is any, due acknowledgement and credit are mentioned accordingly in the e-book.



## PREFACE

This e-book is specially written for polytechnic students who are pursuing Diploma in Architecture.

The content is designed in line with the latest syllabus prescribed in Malaysian polytechnics, and covers the topic of bathroom and water supply in building. Each chapters begin with Learning Outcomes, brief explanation on related matters and quick check questions to improve understanding. This e-book includes guidelines, chart, diagrams and illustrations.

This e-book is developed into few volumes, focusing part by part of the building services component. Volume One, which concentrated on bathroom and restroom design were derived from topic 1 in DCA20092 - Building Services 1.

This book is organized into three chapters. Chapter one gives an overview of building classification and building services. Second chapter provides general information of bathroom design for two-storey house. The last chapter, explains the requirements related to public restroom design in relations to the principles of Universal Design.

Hopefully, this book will contribute towards an understanding of the bathroom and public restroom design.

# TABLE OF CONTENTS



ACKNOWLEDGEMENTS..... i

ABSTRACT..... ii

## 1 INTRODUCTION TO BUILDING SERVICES

1.0 Introduction.....	3
1.1 Building & Its Classification.....	4
i. What is building?.....	4
ii. Residential & Non-residential buildings.....	5
iii. Classification of Residential Buildings - Private dwellings.....	6
iv. Classification of Non-residential Buildings.....	8
1.2 Building Services.....	10
i. What are Building Services?.....	10
ii. Types of Building Services (MEP).....	11
iii. Impact of M&E systems on buildings.....	12
iv. The complexity of M&E systems varies with:.....	12
v. Building Services and Building Regulations in Malaysia.....	13

## 2 BATHROOM DESIGN

2.0 Introduction.....	18
2.1 Uniform Building By Law.....	19
2.2 Types & Materials of Sanitary Fittings.....	20
i. Wash Basins.....	21
ii. Sinks.....	24
iii. Bath Tubs.....	25
iv. Water Closets (WC).....	27
v. Urinals.....	28
vi. Showers.....	29
2.3 Waterproofing.....	31
i. Cementitious Waterproofing.....	32
ii. Liquid Waterproofing Membrane.....	32
iii. Bituminous Membrane & coating.....	33
iv. Polyurethane Liquid Membrane.....	33

2.4 Design Considerations.....	34
i. floor drop level.....	34
ii. circulation & arrangement.....	35
iii. sanitary wares & fitting arrangement.....	36
iv. floor & wall finishes.....	38
2.5 Bathroom Plan & Section.....	40

## 3 PUBLIC RESTROOM DESIGN

3.0 Introduction.....	44
3.1 Uniform Building By Law.....	45
i. Introduction.....	45
ii. Objective.....	45
iii. Minimum dimensions of latrine, water-closet and bathrooms.....	46
iv. Height of room.....	47
v. Natural Lighting and ventilation.....	47
3.2 Malaysian Standard.....	51
i. Introduction.....	51
ii. Objective.....	52
iii. MS 2015.....	52
iv. Users.....	52
v. MS 2015-1 :2017 (Public Toilets- Part 1: Design Criteria).....	53
vi. Design Considerations.....	53
3.3 Universal Design.....	54
i. Introduction.....	54
ii. Guidelines.....	55
3.4 Layout Planning.....	58
3.5 Conclusion.....	59
3.6 Case Study.....	59

REFERENCES..... 61

# CHAPTER 1: INTRODUCTION TO BUILDING SERVICES

1.0 Introduction

1.1 Building & Its Classification

1.2 Building Services

## Main Objectives

Students are able to know the types of building and building services.

Focusing Subtopics

**Objective 1 :**  
Explain types of buildings.

**Objective 2 :**  
Explain types of building services.

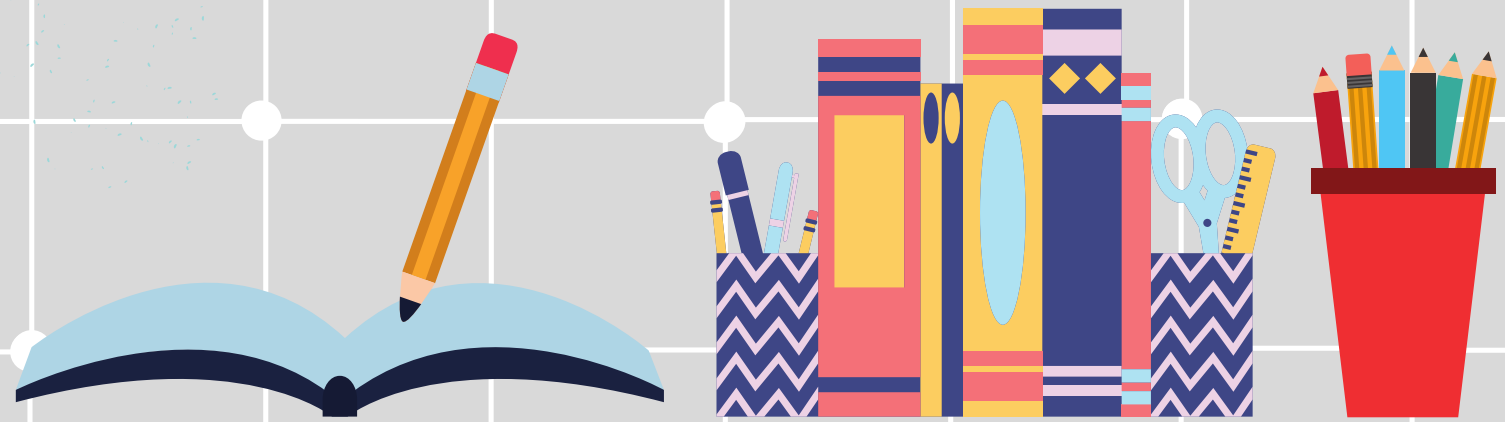

**Main Objectives :**  
know the types of building and Building Services.

# 1.0

# INTRODUCTION

BUILDING SERVICES play a central role in contributing to the design of a building. To design any spaces in a building, one should know what types of building and what kind of technical services are required to design the specified kind of building. This means that building services design must be integrated into the overall building design from a very early stage, particularly on complex building projects.

In the reading for this lesson, building is defined as built structure, permanent or temporary, enclosed within walls and roof, and provide shelter for human habitation. While Building services is defined as systems installed in buildings to make them comfortable, functional, efficient and safe.

In this topic, the types of building and building services will be discussed.

**ARCHITECTURE IS A  
VISUAL ART, AND THE  
BUILDINGS SPEAK FOR  
THEMSELVES.**

*Julia Morgan*

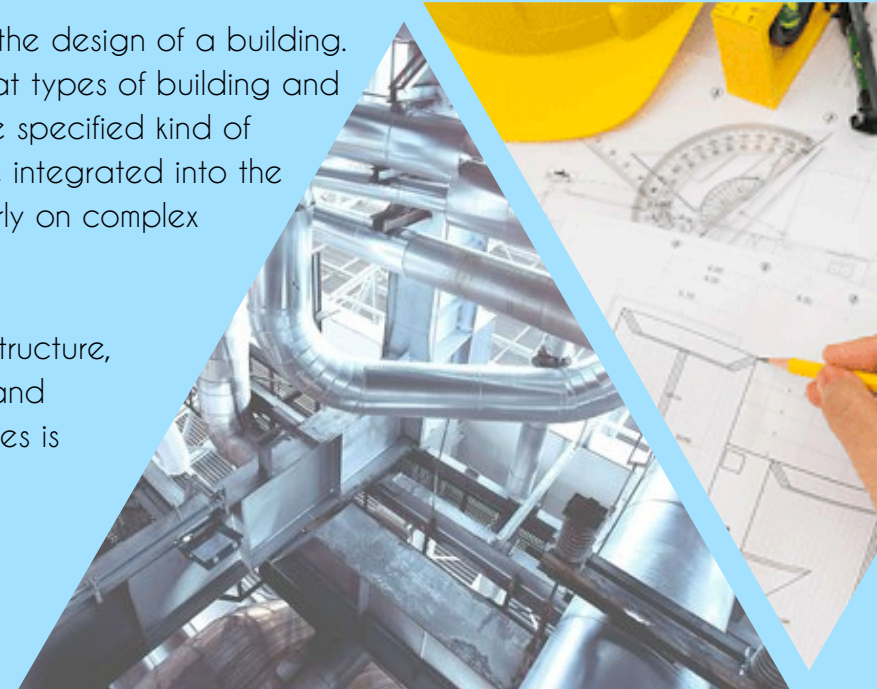

## 1.1 BUILDING & ITS CLASSIFICATION



### i. What is BUILDING ?

A building is defined as any structure that has a roof and walls and stands permanently in one place. It can be any structure that is designed or intended for support, enclosure, shelter or protection of a person, animals or property having a permanent roof that is supported by columns or walls. The different meanings of building is shown as below:

**“A structure with walls and a roof”**

(<http://dictionary.cambridge.org>)



**“Something that is built, as for human habitation; a structure”**

(<http://www.thefreedictionary.com>)



**“A building is any structure with a roof to provide shelter from the weather for occupants or contents, although it may also have other elements”**

(Penguin Dictionary of Building, Fourth Edition, 1995)

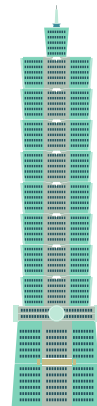

**“Permanent or temporary structure enclosed within exterior walls and a roof, and including all attached apparatus, equipment, and fixtures that cannot be removed without cutting into ceiling, floors, or walls”**

(<http://www.businessdictionary.com>)

### Objective 1 :

Explain types of buildings



### A 'BUILDING' IS...

- Built structure
- Permanent or temporary
- Enclosed within walls and roof
- Provide shelter
- For human habitation

## 1.1 BUILDING & ITS CLASSIFICATION



### ii. Residential & Non-residential buildings

Buildings can be categorized according to size and different functions. The classification of buildings also can be based on occupancy and type of construction. In this topic, buildings are mainly classified into residential and non-residential buildings.

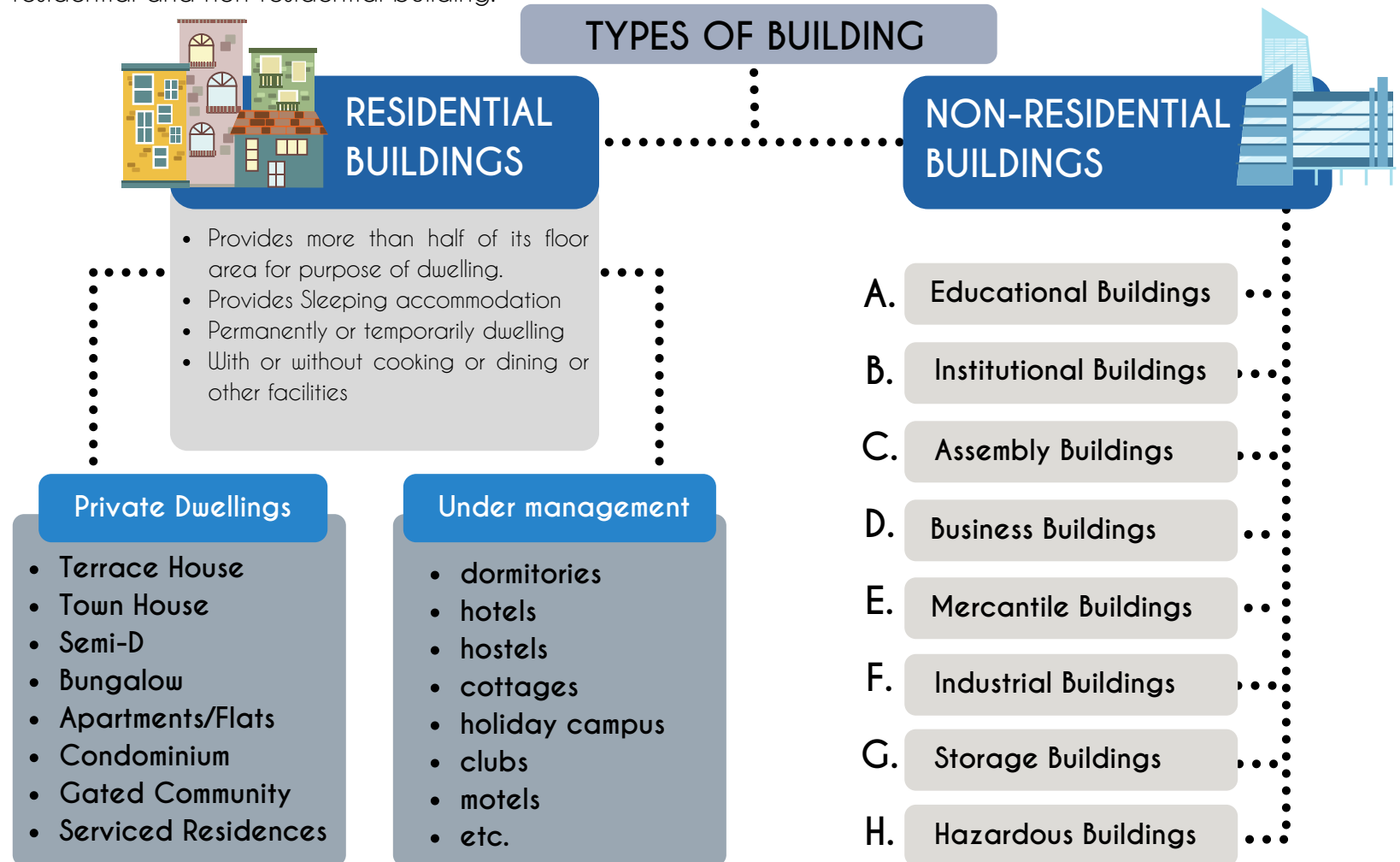

Figure 1.0 : Types of Building



[https://youtu.be/eXxtV\\_U4-zQ](https://youtu.be/eXxtV_U4-zQ)

"WHAT IS RESIDENTIAL BUILDING?"

## 1.1 BUILDING & ITS CLASSIFICATION



### iii. Classification of RESIDENTIAL Buildings - Private dwellings

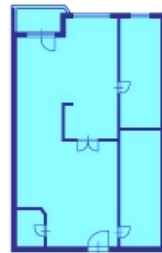

**TERRACE**  
22' x 75'

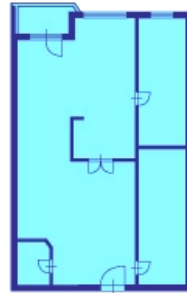

**LINKED HOUSE**  
Larger than terrace

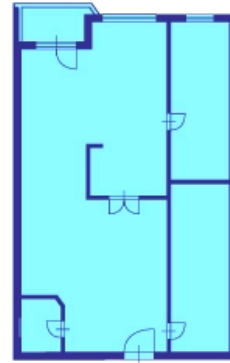

**SUPER-LINK**  
34' x 80'



### B. TOWNHOUSE

Generally, a townhouse is two homes in one, it can be two units will be stacked on top of each other or attached side by side. It also looks like a single home from the outside.



**SEMI-DETACHED**

**DETACHED**

### C. SEMI-DETACHED & DETACHED HOUSE

- A semi-detached house shares one common wall with its neighboring home, its layout will be a mirror duplicate of the other.
- A detached house doesn't adjoin with its neighbouring home and stands alone.

### DISCUSSION 1.

Which type of residential building can be classified as two-storey house?

## 1.1 BUILDING & ITS CLASSIFICATION



### iii. Classification of RESIDENTIAL Buildings - Private dwellings

#### D. MANSION, BUNGALOWS, ZERO-LOT BUNGALOWS, CLUSTER HOMES & VILLAS

- A mansion is a house with a huge plot land and bigger than bungalows and surrounded by gardens.
- Cluster homes are developed in groups, come with a huge build-up and condo facilities.
- Bungalows are like mansions, but slightly smaller in terms of land size.
- Zero lot bungalows are situated at the corner to make full use of the land, similar to bungalows, but with a very small piece of land.
- Villas are like cluster homes, but with a fancier name.



#### E. FLAT & APARTMENT

- A flat is a non-gated and guarded five-storey walk-up residence, with outdoor parking and no other facilities
- an apartment is gated and guarded and is over five stories tall. It comes with lifts and is attached to an outdoor parking space and basic facilities such as playgrounds and landscaping.



#### F. CONDOMINIUMS & SERVICED APARTMENTS

- Condominiums have a full range of facilities, high security with indoor or basement parking bays. It has to be developed in a land area of 4,000 square metres and above.
- Serviced Apartments, Serviced Residences and Serviced Suites come with housekeeping facilities, room service, bellboy services and other facilities just like a hotel.



Main spaces in residential building:

- Living Room
- Bedroom
- Kitchen
- Dining
- Bathroom

## 1.1 BUILDING & ITS CLASSIFICATION



### TYPES OF BUILDING:

- Residential Buildings
- Educational Buildings
- Institutional Buildings
- Assembly Buildings
- Business Buildings
- Merchantile Buildings
- Industrial Buildings
- Storage Buildings
- Hazardous Buildings



### iv. Classification of **NON-RESIDENTIAL** Buildings



#### A. EDUCATIONAL BUILDINGS

Buildings that are meant for education. In examples are schools, colleges, libraries, universities, training institutes, etc.



#### C. ASSEMBLY/COMMUNITY BUILDINGS

Building where groups of people gather or assemble for religious, recreation, amusement, social, patriotic or similar purposes. Examples are places of worship, theatres, museums, cinema halls, assembly halls, auditoriums, exhibition halls, gymnasiums, restaurants, passenger stations, public transportation services, etc.

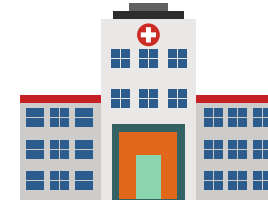

#### B. INSTITUTIONAL BUILDINGS

Any building which is used for the purposes such as health, medical, recovering health after illness, physical or mental disease, care of infants or aged persons, penal detention, etc. Normally offer sleeping accommodation for the occupants. For examples hospitals, sanatoria, custodial, institution, etc.



#### D. BUSINESS BUILDINGS

A building that provides transaction of business, keeping of accounts and records, barber shops, dispensaries and clinics, news stands, banks, city halls, etc.

## 1.1 BUILDING & ITS CLASSIFICATION



### DISCUSSION 2.

Which type of building can be Public Restroom categorised?

### FUN FACT



### "form follows function"

This phrase coined by architect Louis H. Sullivan in his 1896, is a principle of design, which states that the shape of a building or object should primarily relate to its intended function or purpose.



## iv. Classification of **NON-RESIDENTIAL** Buildings



### E. MERCANTILE BUILDINGS

Building which is used as stores, shops, market for sale and either wholesale or retail for displaying products or wares



### G. STORAGE BUILDINGS

Building structures which are primarily used for storage or sheltering of goods, wares, merchandise, vehicles or animals. Examples are warehouses, cold storages, depots, storehouses, truck terminals, garages, etc.



### F. INDUSTRIAL BUILDINGS

Building or structure in which products are fabricated, assembled, or processed. For examples factories, laundries, laboratories, assembly plants, power plants, gas plants, refineries, etc.

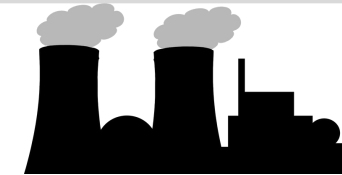

### H. HAZARDOUS BUILDINGS

Building that functions as a storage, handling, manufacture of materials that are liable to burn with extreme rapidity and prove hazardous to health, storage of gases under high pressure or for storage and handling of highly flammable liquids or explosive materials, explosives, fireworks, etc.

## 1.2

## BUILDING SERVICES



## i. What are BUILDING SERVICES?



"BUILDING SERVICES" are the systems installed in buildings to make them comfortable, functional, efficient and safe. The function of the building is incomplete without the building services. The purpose is not only to provide shelter. Basically building services is what make the building comes to life i.e. what makes the building work. It can broadly group as mechanical and electrical installations and plumbing installations. Building services contribute largely to the sustainability & functioning of the building. Hence, everything inside a building that makes it safe and comfortable is called 'Building services'. Other different meanings of building services are listed below:



## Objective 2 :

Explain types of building services



<https://youtu.be/TvJCm7xug8E>

"BUILDING SERVICES:  
INTRO TO INDUSTRY"

**Buildings must do what it was designed to do. They do more than not just provide shelter from sun, wind and rain; they must also provide a safe and healthy environment in which people can live, work and achieve.**

- Safety
- Comfort
- Efficiency

(Chartered Institute of Building Services Engineers - CIBSE)

**It generally includes all the mechanical and electrical systems within a building (lighting, heating, ventilation, air conditioning) plus the public health and drainage systems.**

**In most cases, it will involve an assessment of the thermal properties of the building and the natural ventilation.**

(Penguin Dictionary of Building, Fourth Edition, 1995)

1.2 BUILDING SERVICES

**DISCUSSION 3.**

Which type of building technical services is needed for a bathroom design?



Building services are what make a building comes to life.....



ii. Types of BUILDING SERVICES (MEP)

Classification of Building Services are mainly divided into: Mechanical Systems, Electrical Systems And Building Operation System. They are all very important part of planning, designing and construction of a building.

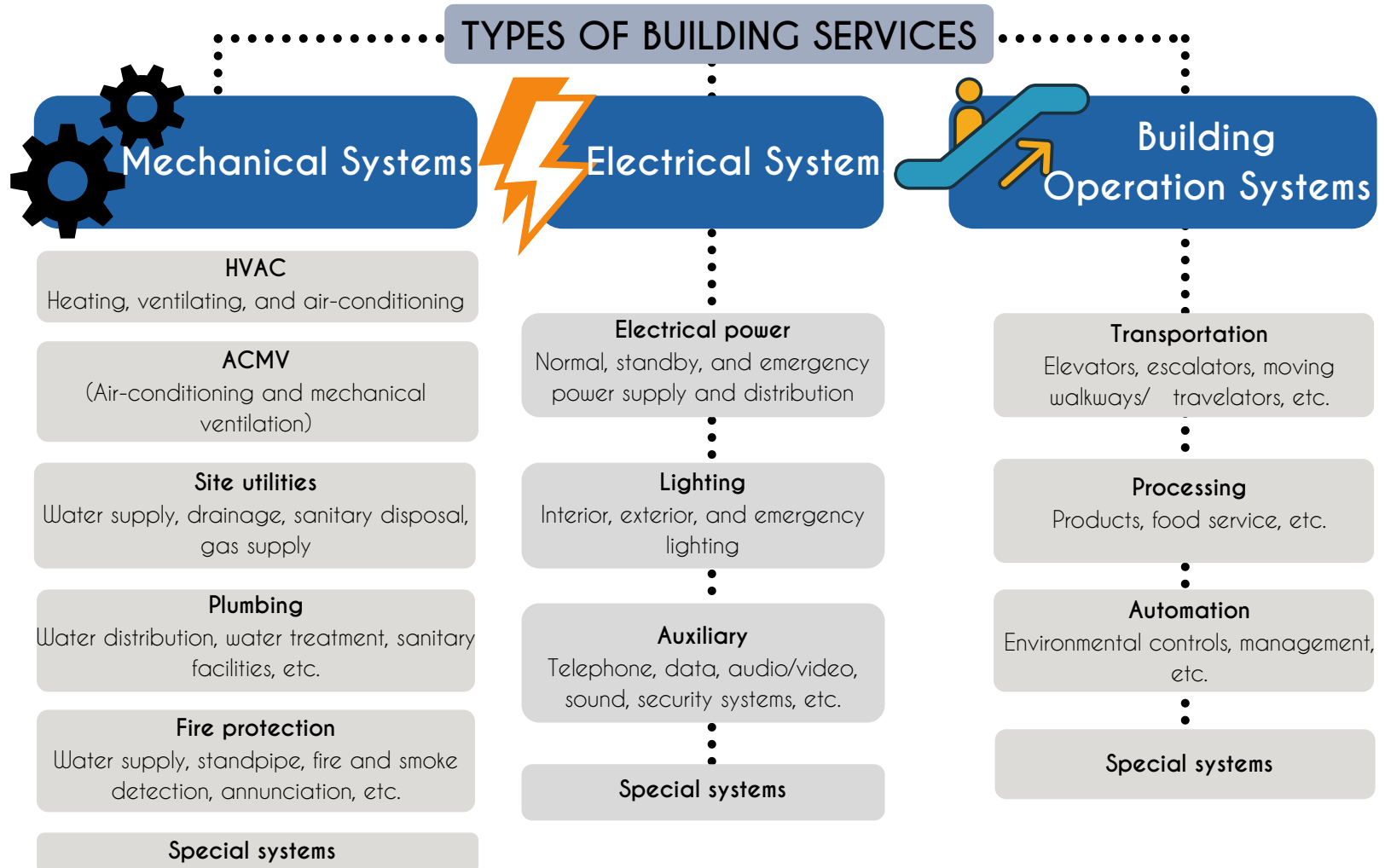

Figure 1.1 : Types of Building Services

## 1.2 BUILDING SERVICES

### FUN FACT



The complexity and impact of building services has not always been appreciated,

as indicated by the architect Louis Kahn when in 1964 he wrote disparagingly in *World Architecture*:

'I do not like ducts, I do not like pipes. I hate them so thoroughly, I feel that they have to be given their place. If I just hated them and took no care, I think they would invade the building and completely destroy it.'



### iii. Impact of M&E systems on buildings

·There are several impacts of M&E systems on buildings that have been identified. Firstly, the demand for significant amounts of floor and ceiling space as allocation of a proper space is required and must be considered during the preliminary planning.

·M&E systems also add to the total cost of the building construction. For example, the design of sophisticated and refined buildings, like research buildings, hospitals, computer centres.

·Apart from that, M&E systems can also cause an increase in energy consumption because the energy consumed by occupied buildings, including residential, commercial, institutional and industrial facilities, account for 50% of all energy usage by an industrialized country.

it also contributes for a large portion of the operating building costs.



### iv. The complexity of M&E systems varies with:

- Living standards of the society
- Climatic conditions of the region
- Occupancy and quality of the building



## 1.2 BUILDING SERVICES

### FUN FACT



Some architects have even featured the pipes and ducts on the outside of their designs, namely



the Pompidou Centre in Paris (Renzo Piano and Richard Rogers) and



the Lloyds Building in London (Rogers).



### v. Building Services and Building Regulations in Malaysia

Starting the designing of a building, designers must comply with building regulations set by the government authorities. The regulations should be followed strictly by any person or organization. Some of the building regulations and guidelines that can be related to building services are as follows:

- Uniform Building By-Laws 1984
- MS1525 : CODE OF PRACTICE ON ENERGY EFFICIENCY AND USE OF RENEWABLE ENERGY FOR NON-RESIDENTIAL BUILDINGS
- MALAYSIAN STANDARD MS 2015-1: 2017 (PUBLIC TOILETS- PART 1: DESIGN CRITERIA)
- MALAYSIAN STANDARD MS IEC 60364- ELECTRICAL INSTALLATIONS OF BUILDINGS
- MS 1979: ELECTRICAL INSTALLATIONS OF BUILDINGS- CODE OF PRACTICES
- Uniform Technical Guidelines Water Reticulation And Plumbing (1st ed.) (2014) SPAN

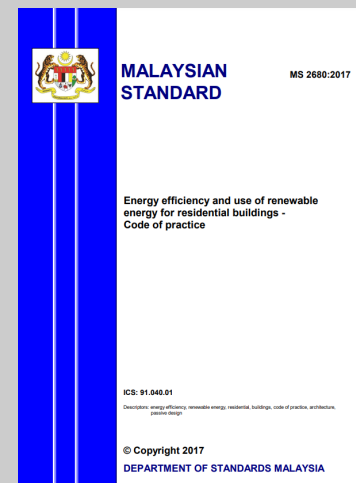
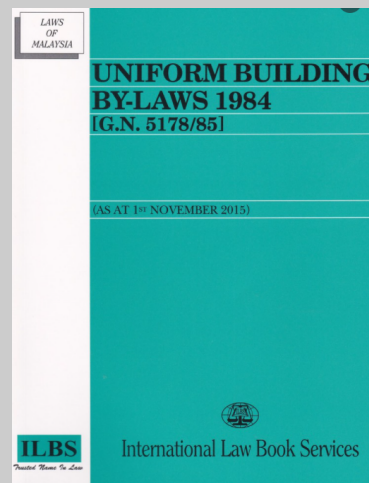

Figure 1.2 : Building Regulations & Guidelines in Malaysia



**Buildings must be designed with features to provide:**

- better lighting
- comfortable space temperature, humidity and air quality
- convenient power and communication capability
- high quality sanitation; and
- reliable systems for the protection of life and property.



**DISCUSSION  
FEEDBACK**

1.

Which type of residential building can be classified as a single and two-storey house?

**Answer:**

*Terrace, link, superlink house, townhouse, semi-detached house, detached house, mansion, bungalows, zero-lot bungalows, cluster homes & villas*



**DISCUSSION  
FEEDBACK**

2.

Which type of building can be Public Restroom categorised?

**Answer:**

*Public Restroom can be free-standing or integrated into every type of public building*



**DISCUSSION  
FEEDBACK**

3.

Which type of building technical services is needed for a bathroom design?

**Answer:**

*Mechanical Systems (ACMV, Site utilities & Plumbing)  
Electrical Systems (Electrical power & Lighting)*



<https://quizizz.com/admin/quiz/5b45a85198199000190fc96e>

"INTRO TO BUILDING SERVICES"

### FUN FACT



#### Relevant terms....

- Building services engineering
- Facilities and services engineering
- Building engineering
- Architectural engineering
- Building technology

## REMEMBER THIS!

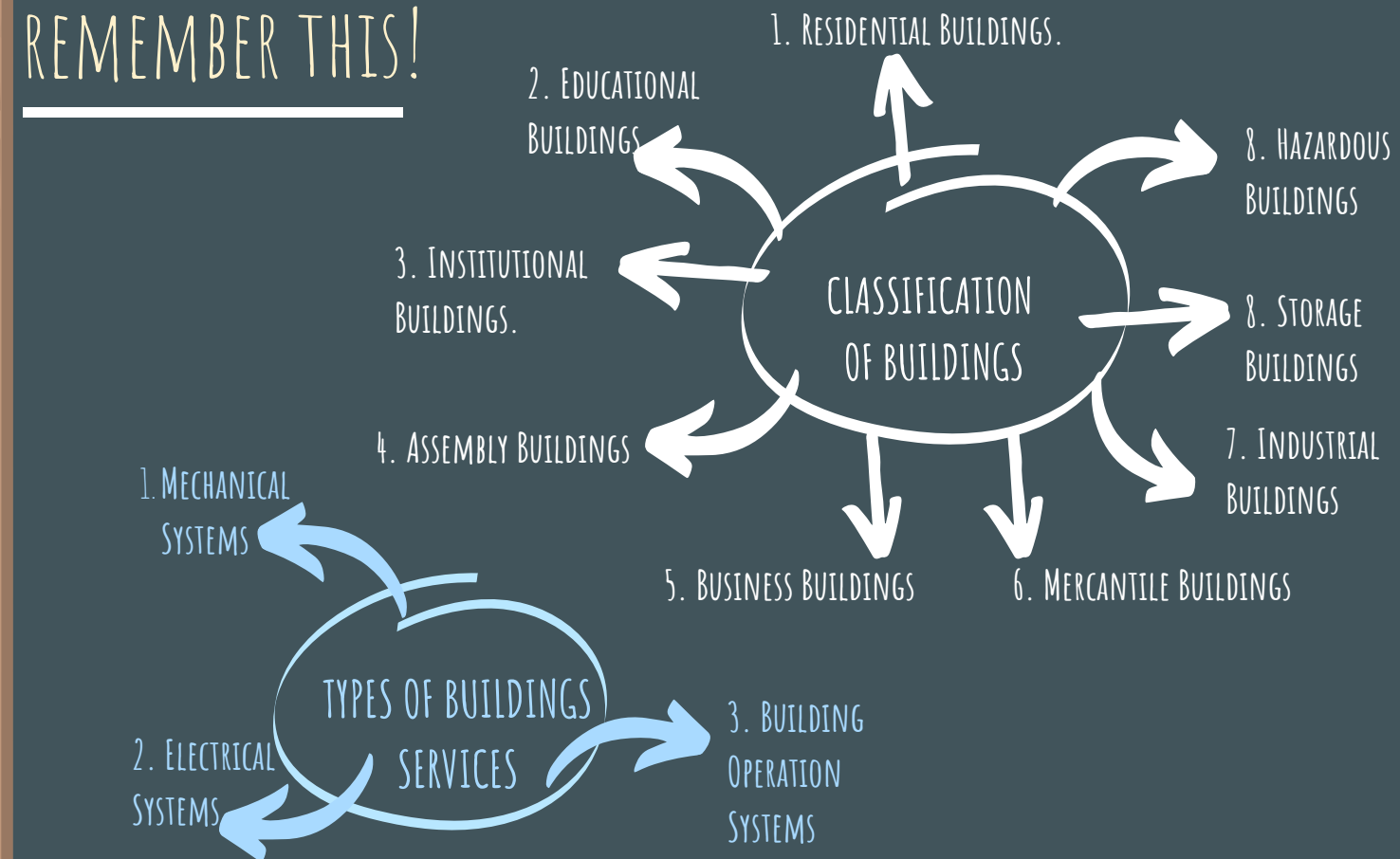

**TAKE QUIZ**



1. List types of non-residential buildings. (sect 1.1, pg.5)
2. What are the impact of M&E systems on buildings? (sect 1.2, pg.12)
3. Give TWO (2) examples of building regulations and guidelines that can be related to building services in Malaysia. (sect 1.2, pg.13)

# CHAPTER 2

# BATHROOM DESIGN

- 2.0 Introduction
- 2.1 Uniform Building By Law
- 2.2 Types & Materials of Sanitary Fittings
- 2.3 Waterproofing
- 2.4 Design Considerations
- 2.5 Bathroom Plan & Section

## Main Objective

Students able to apply knowledge of bathroom design into design-based task (maximum two- storey house)

## Focusing Subtopics

**Objective 1 :**

- Minimum width and height of residential bathroom according to Uniform Building by Laws.

**Objective 2 :**

According to the Uniform Building Code, a residential bathroom must have minimum openings for natural ventilation and lighting.

**Objective 3 :**

Types of sanitary wares/ fittings and the materials.

**Objective 4 :**

Waterproofing methods for floor and wall of bathroom.

**Objective 5 :**

- Design consideration of residential bathroom in term of floor drop level, circulation, arrangement of sanitary wares/ fittings floor finishes and wall finishes.

**Objective 6 :**

Construct a drawing consists of a plan and section(s) of bathroom(s) for a house in compliance with Uniform Building by Laws, complete with label, dimension and specifications.

**Main Objective :**

Apply knowledge of bathroom design into design-based task (maximum two-storey house)

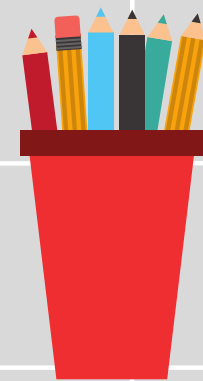

# 2.0

# INTRODUCTION

## What is Bathroom?

BATHROOM is a room, in a residential building containing a shower, wash basin and water cistern. It is also known as a restroom, washroom, toilet or lavatory. A bathroom commonly known as an important space in a house, but a bathroom is a space to take care of ourself in privacy. A bathroom is a key space in any residential type where it serves a fundamental hygenic function.

Starting the designing of a building, designers must comply with building regulation set by the government authorities. The regulations shuld be followed strictly by any person or organization. In this topic, we will discussed the requirements related to bathroom design for both residential and public toilet.



Figure 2.0 : Traditional concept of Malaysian open bathroom

## 2.1 UNIFORM BUILDING BY LAW (UBBL)

### Objective 1:

Explain minimum width and height of residential bathroom according to Uniform Building by Laws

### Objective 2 :

Explain minimum openings for natural lighting and natural ventilation of residential bathroom according to Uniform Building by Laws.

## UNIFORM BUILDING BY LAWS 1984 (UBBL)

According to UBBL 1984, the minimum requirement in bathroom layout design was stated in By Laws (height) and (natural lighting). The purpose is to ensure the health and safety of building occupants.

### Minimum width and height of residential bathroom in accordance with Uniform Building by Laws.

- In the case of bathroom, not less than 1.5 square metre width of not less of 0.75 metre.
- In the case of bathroom with close fittings not less than 2 square meters width of not less than 0.75 meters

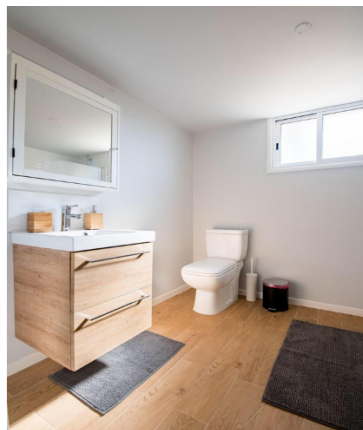
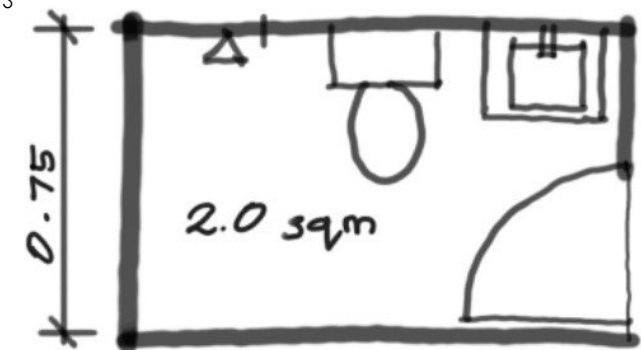
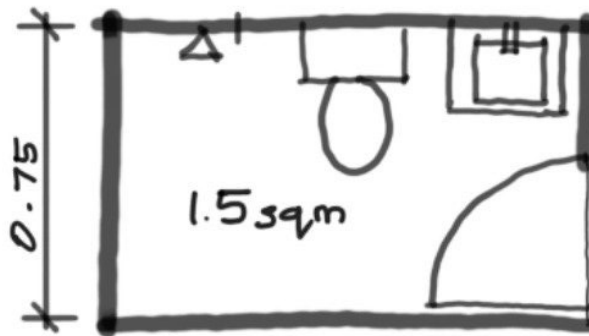

### Minimum openings to allow for natural lighting and ventilation of residential bathroom according to Uniform Building by Laws.

Every water closet, urinal, or bathroom must have natural lighting and ventilation provided by one or more openings with a total area of not less than 0.2 square metre per water closet, urinal, or bathroom laterine, and such openings must be capable of a free continuous passage of air.

## 2.2 TYPES OF SANITARY FITTINGS & MATERIALS

### Types of Sanitary Fittings

#### Sanitary Fittings

The term sanitary ware is a slightly ambiguous one that in very general terms refers to sanitary appliances found in installations, such as toilets and bathrooms.

#### Sanitary Materials

Sanitary appliances made from a wide range of materials, including metals, acrylics, glass, and so on, and sanitary ware is sometimes now interpreted to include a wider range of appliances that might be found in sanitary installations such as baths, showers, bins, incinerators, macerators, and so on.

WCs, wash basins, urinals, sinks, and shower trays are all made of this material. The term "ceramic" refers to a material created by burning clay. The materials' strength and degree of impermeability are determined by the clay mixture's composition and the temperature at which they are set.

This results in a durable appliance that can withstand knocks and damage. Urinals, sinks, and toilet pans made of fireclay are commonly found in schools and factories.



This produces appliances that are brightly coloured, lend themselves easily to the fabrication of complex designs, and are relatively inexpensive. It is mostly utilised in sinks and toilet pans.

This results in a durable appliance that can withstand knocks and wear, but unlike earthenware and fireclay, the material is non-absorbent even when unglazed. It's mostly utilised for sinks, channels, and urinal stalls.



### Objective 3 :

Explain types of sanitary wares/ fittings and the materials.

## 2.2 TYPES OF SANITARY FITTINGS & MATERIALS

Types of Sanitary Fittings;

i. Wash Basins

### I. WASH BASINS

•A wash basin is typically made of clay, white glazed earthenware, enamelled iron, or other similar materials. They are sometimes made of pressed steel or plastic.

• Wash basins are divided into two types: flat back and angle back.

•An conventional wash basin with brackets attached to the wall. A pedestal rises from the wall. They come in a variety of forms and sizes.

•Angle back wash basins come in a variety of sizes as shown below:

630 x 450 mm

550 x 400 mm

450x 300 mm

•Angle back wash basins come in a variety of sizes as shown below:

600 x 480 mm

400 x 400 mm

•It has an oval-shaped bowl with a top overflow port. At the bottom of the bowl is a waste pipe with a metallic strainer.

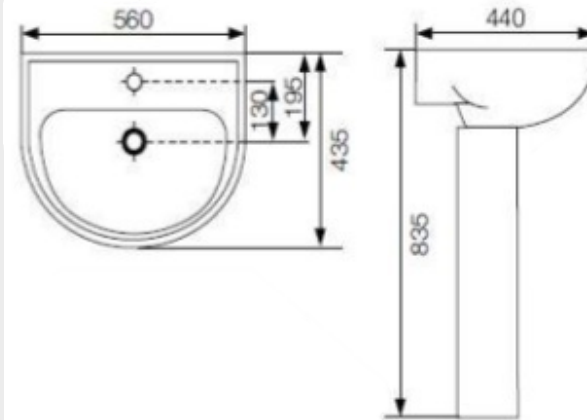

#### Materials of Wash basins

Cast Polymer

•A cast polymer is blended with marble elements to create cast polymer basins. To make a strong body, a gel coating is usually applied. This is well-known for its durability and strength. However, depending on how you use it, the shine on your basin may fade over time.

Composite

•Acrylic resins and grounded compounds are used to create composite basins. This has a solid colour and is extremely durable. However, you will have to spend more money on such materials.

•Copper

•When you have a great copper basin to work with, you can create a warmer aesthetic in your bathroom. This is a long-lasting choice, but it is also somewhat costly.

#### Objective 3 :

Explain types of sanitary wares/ fittings and the materials.

## 2.2 TYPES OF SANITARY FITTINGS & MATERIALS

Types of Sanitary Fittings;

i. Wash Basins

### Basin Shape



Oval



Round



Rectangular

### Type of Wash Basin

#### Wall-Mounted Ceramic Basins

-A wall-mounted basin is precisely what it says on the label. This is a bathroom basin with a robust body that hangs from the wall. This is ideal for people with limited workspace or who like a minimalist style. The plumbing fixtures are visible, but this can give the bathroom a unique look. This layout also provides more free area for storage.



-They are reasonably priced and simple to install. Because they are affixed directly to the bathroom walls, wall-mounted ceramic basins do not require a separate table or counter to keep them in place.

### Objective 3 :

Explain types of sanitary wares/ fittings and the materials.



## 2.2 TYPES OF SANITARY FITTINGS & MATERIALS

Types of Sanitary Fittings;

i. Wash Basins

### Objective 3 :

Explain types of sanitary wares/ fittings and the materials.

### Type of Wash Basin



#### Table-Mounted Ceramic Basins

-They are simple to set up in the bathroom. Simply build a robust counter on which to mount the washbasin and set the basin on top.



#### Coloured Ceramic Wash Basins

-In the same way as the wall-mounted and table-mounted ceramic basins mentioned above, except that they come in different colors.

Material: A wash basin is usually made of pottery or white glaze earthenware of enamelled iron etc. They were often made of pressed steel or plastic.

#### Pedestal Basins

-A pedestal basin is made with the plumbing hardware covered up. In particular, the basin drops down well to the point that the pipes and other plumbing fittings are hidden. This is best for spots for little space and this works well for limited space areas and requires only a little or none-at-all added storage areas.



#### Corner Basin

-A corner basin is designed to fit into the corner of a bathroom rather than against a flat wall. In this scenario, the major fittings are positioned around the corner, while the basin's sides protrude from the walls. A fantastic solution for a small bathroom with limited space.



## 2.2 TYPES OF SANITARY FITTINGS & MATERIALS

Types of Sanitary  
Fittings;  
  
ii. Sink



Type of Sink

## II. SINK

### Double Basin/Bowl Sink

-Dual basins are the most common type of kitchen sink basin configuration, allowing for washing on one side and rinsing or drying on the other.



### Single Basin/Bowl Sink

-Single basin sinks are a type of kitchen sink that includes both farmhouse (apron) and in-counter sinks. This sink does not have a divided basin.

### Vessel sink

-A popular style of bathroom sink that casts directly on a counter. Faucets can be wall-mounted above a vessel sink, but they're more usually found rising from the countertop.

### Drop-In Bathroom Sink

-Bathroom sinks are simple to install, fitting through a pre-cut hole in the countertop with the sink rim sitting on the surface to complete the lavatory's appearance.



### Undermount Sink

-Top-mount sinks are fastened to the top of the counter with special clips, whereas undermount sinks are attached to the bottom of the counter with special clips.



### Objective 3 :

Explain types of  
sanitary wares/ fittings  
and the materials.

## III. BATHTUB

### 2.2 TYPES OF SANITARY FITTINGS & MATERIALS

Types of Sanitary  
Fittings;

iii. Bathtub

#### Generic Bathtub

-This is usually installed in a house for the purpose of providing a bath experience to family members and perhaps may involve the pets, e.g. dog, tortoise, small mammals to enjoy a dip especially during the



hot summer weather. It is usually white in colour with a shower head above and enclosed to allow a sit-down or stand-up shower.

#### L-Shape bath

-Provides you an indulgent bathing experience and it's a magnificent touch to your bathroom.



#### Type of Bathtub

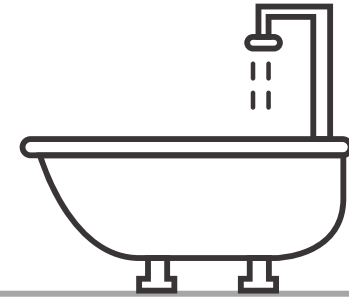

#### Corner Bathtub

-Maximise space in the tiniest of bathrooms and add an element of charm as well. If your bathroom has a tricky layout this bathtub will work well.

And since you can fit this bathtub in both left and right-handed positions, it provides user with supreme convenience .

#### L-Soaking bath

-A full body and head immersion in a bath tub full of water is required for a proper bathing experience. This tub would be deeper than the standard generic tub, allowing it to store more water.



There are a variety of sizes, styles, and shapes to pick from, as one might expect.

### Objective 3 :

Explain types of sanitary wares/ fittings and the materials.

## 2.2 TYPES OF SANITARY FITTINGS & MATERIALS

Types of Sanitary  
Fittings;

iii. Bathtub

Materials of Sanitary  
Fittings

### Objective 3 :

Explain types of  
sanitary wares/ fittings  
and the materials.

### Type of Bathtub

#### P-Shape bath

-Has an infill in the extended part that reduce the amount of water required to fill the bath. The amount of usable bath space is not reduce. This feature give you extra space for showering. Both left or right handed option are available.



#### Material:

Bathtub usually made of iron or steel coated with enamel, fibreglass, ceramic tile, cultured marble, porcelain or plastic. They might have tapering sides or parallel sides.



#### Ceramic Tile

-Ceramic tile bathtubs can be custom-made on-site to any size and shape. This material gives you more design options than any other. However, all that grout will require upkeep, and the irregular internal surface may not be the most comfortable to relax on with bare skin.

#### Fiberglass

-This is also known as FRP, or fiberglass-reinforced plastic, and is the most affordable bathtub material. Forming layers of fibreglass into the desired shape, then coating it with Gelcoat resin, is how a fiberglass bathtub is manufactured.



#### Cultured Marble

-Crushed limestone is combined with resin and coated with Gelcoat on these tubs. Color, size, and design are all available, and the Gelcoat finish used on cultured marble is more durable than that used on fiberglass. The price is usually halfway between that of acrylic and that of cast iron.

## 2.2 TYPES OF SANITARY FITTINGS & MATERIALS

Types of Sanitary  
Fittings;

iv Water Closet

### Objective 3 :

Explain types of  
sanitary wares/ fittings  
and the materials.

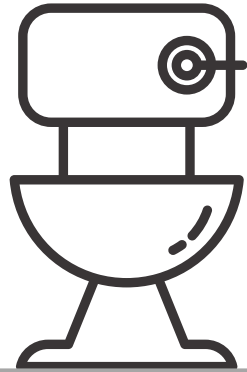

#### Flushing/ Upflush toilet

- This smart design toilet Saniflo is an ideal example of various toilet designs.
- What makes upflush toilets distinctive is that, according to Saniflo's technology, you can put a toilet anywhere in your house because you don't need a drain line next to it.

### Types of Water Closet

## IV. WATER CLOSET

#### One-piece toilet

- This is one of the toilet types in which the toilet tank is attached to the bowl, resulting in a homogeneous ceramic unit.
- Purchasing a one-piece toilet usually includes a toilet seat, so this isn't an issue. The only disadvantage is likely the cost, but it is well worth it.



#### Material

Made of stable , porcelain or vitreous China although sometimes are made of glazed cast iron , steel or stainless steel



#### Two-piece toilet

- This is likely one of the most widely used toilets on the continent.
- Unlike the one-piece toilet, the water tank and the bowl are separated, allowing the tank to hold more water.

2.2 TYPES OF  
SANITARY FITTINGS  
& MATERIALS

Types of Sanitary  
Fittings;  
  
v. Urinals



# V. URINALS

## Types of Urinals

Only liquid human waste is accepted and disposed of in them. Ceramic slab urinals, stall urinals, and bowl urinals are the three types of urinals available.

The slab type is less expensive than the stall type, but it lacks the same level of privacy. The use of ceramic bowl-style urinals, which have a smaller fouling surface than slab and stall urinals.

The minimum distance between urinals must be 30 inches from centre to centre. The distance between a urinal and the sidewall must be at least 15 inches. 1950mm in height, 1000mm in width, and 1200mm in length (deep).

### Corner urinal

-It is type of flat back urinal but it is designed of o fit in the corner of the wall. It save place



### Flat back urinal

-This is urinal is designed to fix in the wall with a screw. This urinal is light in weight and has a compact design.



Slab Urinal



Bowl Urinal



Stall Urinal



### Objective 3 :

Explain types of sanitary wares/ fittings and the materials.

## 2.2 TYPES OF SANITARY FITTINGS & MATERIALS

Types of Sanitary  
Fittings;  
vi. Shower

### Objective 3 :

Explain types of  
sanitary wares/ fittings  
and the materials.

# VI. SHOWER



Types of Shower

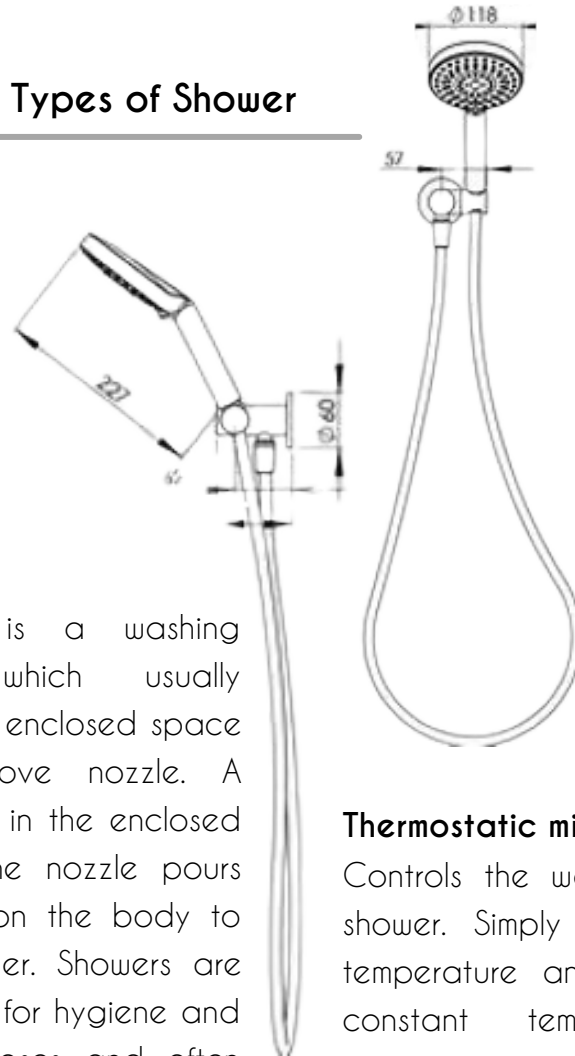

AA shower is a washing appliance which usually consists of an enclosed space with an above nozzle. A human stands in the enclosed area while the nozzle pours water down on the body to utilise a shower. Showers are primarily used for hygiene and washing purposes and often installed in bathroom.

### Manual mixer shower

It's the old-fashioned kind of shower. It can still be found in the majority of modern bathrooms. Every time you shower, it combines hot and cold water.

Each time you shower, adjust the valve controls to your preferred temperature.



### Electric shower

An excellent choice when remodelling a home basement since they don't need to be connected to a hot water supply.

### Thermostatic mixer shower

Controls the water temperature for each shower. Simply set it to your preferred temperature and each shower will have constant temperature. The reliable temperature controls help to prevent scalding especially when there are little children as well as elderly around.



## 2.2 TYPES OF SANITARY FITTINGS & MATERIALS

Types of Sanitary  
Fittings;

vi. Shower

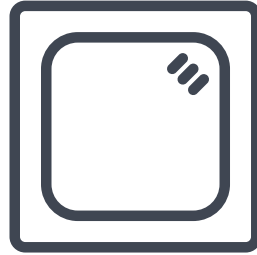

Types of Shower Tray

The shower tray is a component of shower enclosure. It's a prefabricated tray that turns the shower recess into a hob. The function of shower tray is to direct the water flow to the drainage point in bathroom.

Shower trays vary in size and style are designed to suit a range of styles and room. The typical size of shower trays are :

- 915mm x 915mm x 178mm
- 760mm x 760mm x 178mm
- 610mm x 610mm x 178mm

Most shower trays are finished with smooth white acrylic which makes it comfortable to use and easy to clean. Meanwhile the material of shower tray was made of stone resin, a material that mimics the appearance and durability of natural stone.



### Objective 3 :

Explain types of sanitary wares/ fittings and the materials.

## 2.3 WATERPROOFING



Toilets must be waterproofed to prevent water from seeping through the floor slab and walls, as toilets utilize water and have plumbing systems.

Types of Bathroom Waterproofing

### Types of waterproofing for floor and wall of bathroom.

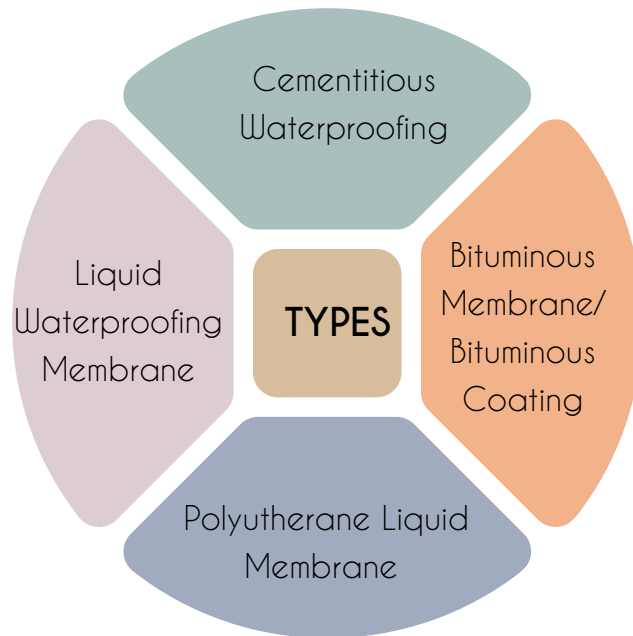

### Waterproofing method for floor and wall of bathroom.

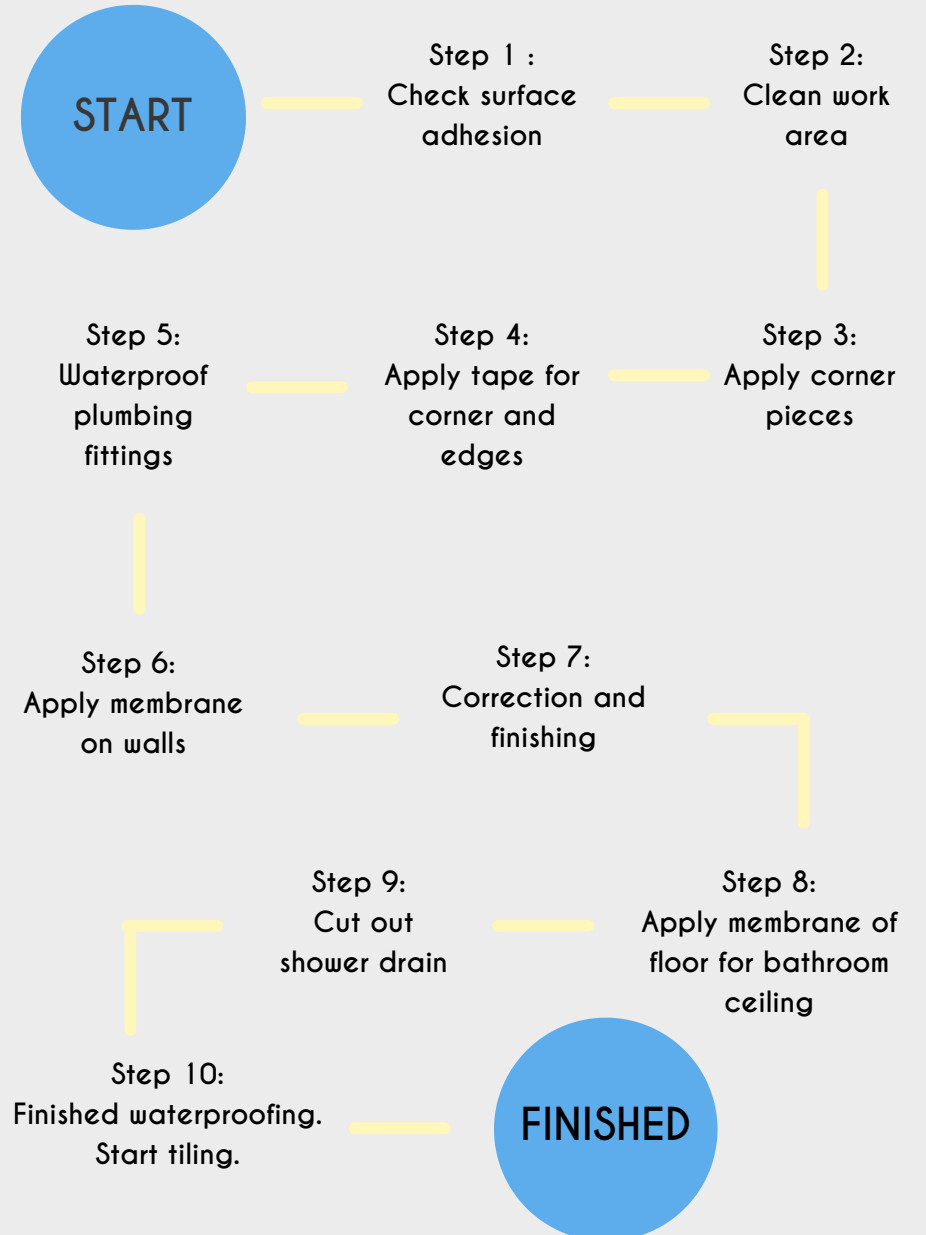

#### Objective 4 :

Explain waterproofing methods for floor and wall of bathroom.

## 2.3 WATERPROOFING

### Types of Bathroom Waterproofing

### Types of Waterproofing



#### i. Cementitious Waterproofing

- Internal damp places, such as toilets, frequently employ this system. This approach is usually a rigid or semi-flexible type of waterproofing, however it is not exposed to sunlight or weathering because it is utilised in inside spaces such as toilets.



#### ii. Liquid Waterproofing Membrane

- Liquid membrane is a thin coating that usually consists of a primer coat and two top coats applied by spray, roller, or trowel. It has more flexibility than cementitious waterproofing solutions.
- On the wall, the liquid hardens into a rubbery layer. The type of polymer used by the producer to make the liquid waterproofing has an impact on the coating's durability.



#### Objective 4 :

Explain waterproofing methods for floor and wall of bathroom.

## 2.3 WATERPROOFING

### Types of Bathroom Waterproofing

#### Objective 4 :

Explain waterproofing methods for floor and wall of bathroom.

#### iii. Bituminous Membrane

- Because of its known performance, bituminous membrane waterproofing is a suitable option for low-sloped roofs. Torch-on and self-adhesive membranes are available for bituminous waterproofing membranes.
- There are two forms of torch on membrane: exposed and covered. To survive the wear and tear of weathering, exposed membranes frequently have mineral granular aggregate, while other types of membranes require the application of a protective screed to avoid penetration.



#### Bituminous Coating

- Asphalt coating is another name for bituminous coating. Bituminous coatings are most commonly used in locations where the screed is still wet. It works well as a protective coating and waterproofing agent, particularly on concrete foundations.



#### iv. Polyurethane Liquid Membrane

- The flat roof surface that is exposed to weathering is waterproofed using a polyurethane liquid membrane.
- This form of waterproofing is costly.
- Higher flexibility is possible with Polyurethane Liquid Membrane.



## 2.4 DESIGN CONSIDERATIONS

### BATHROOM SPACE PLANNING

- Identify common bathroom measurements.
- You can plan your redesign more efficiently if you know a few important metrics, such as the size of a common bathtub and how much space is required for a toilet.

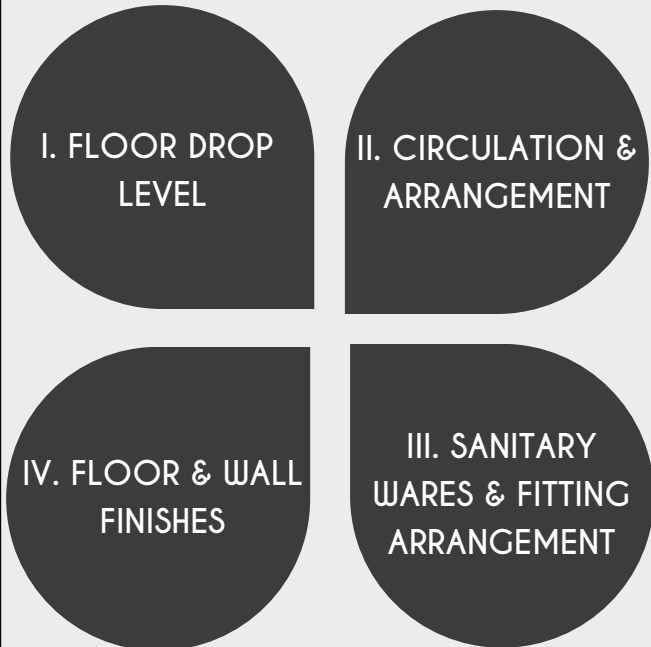

### DESIGN CONSIDERATIONS

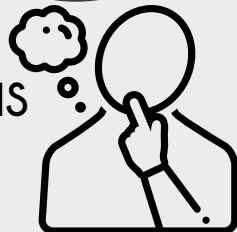

I. FLOOR DROP LEVEL

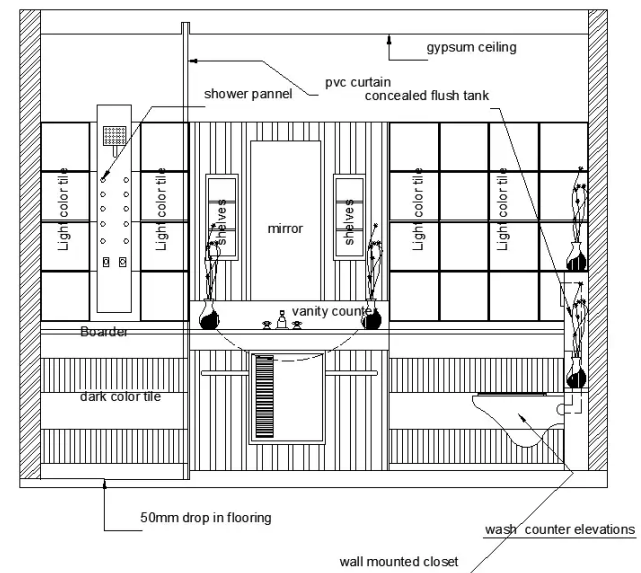
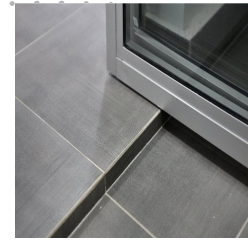

**Objective 5 :**  
Identify design consideration of residential bathroom in term of floor drop level, circulation, arrangement of sanitary wares/ fittings floor finishes and wall finishes.

## 2.4 DESIGN CONSIDERATIONS

### Design Considerations in Designing Bathroom

#### II. CIRCULATION & ARRANGEMENT

A bathroom must have sufficient space to use the bathroom, not just space for the fittings. The layout is affected by the recommended clearance for each bathroom fixtures. The recommended clearances are important for safe and comfortable movement within the bathroom space.

Source : <https://homedesigntutorials.com/>

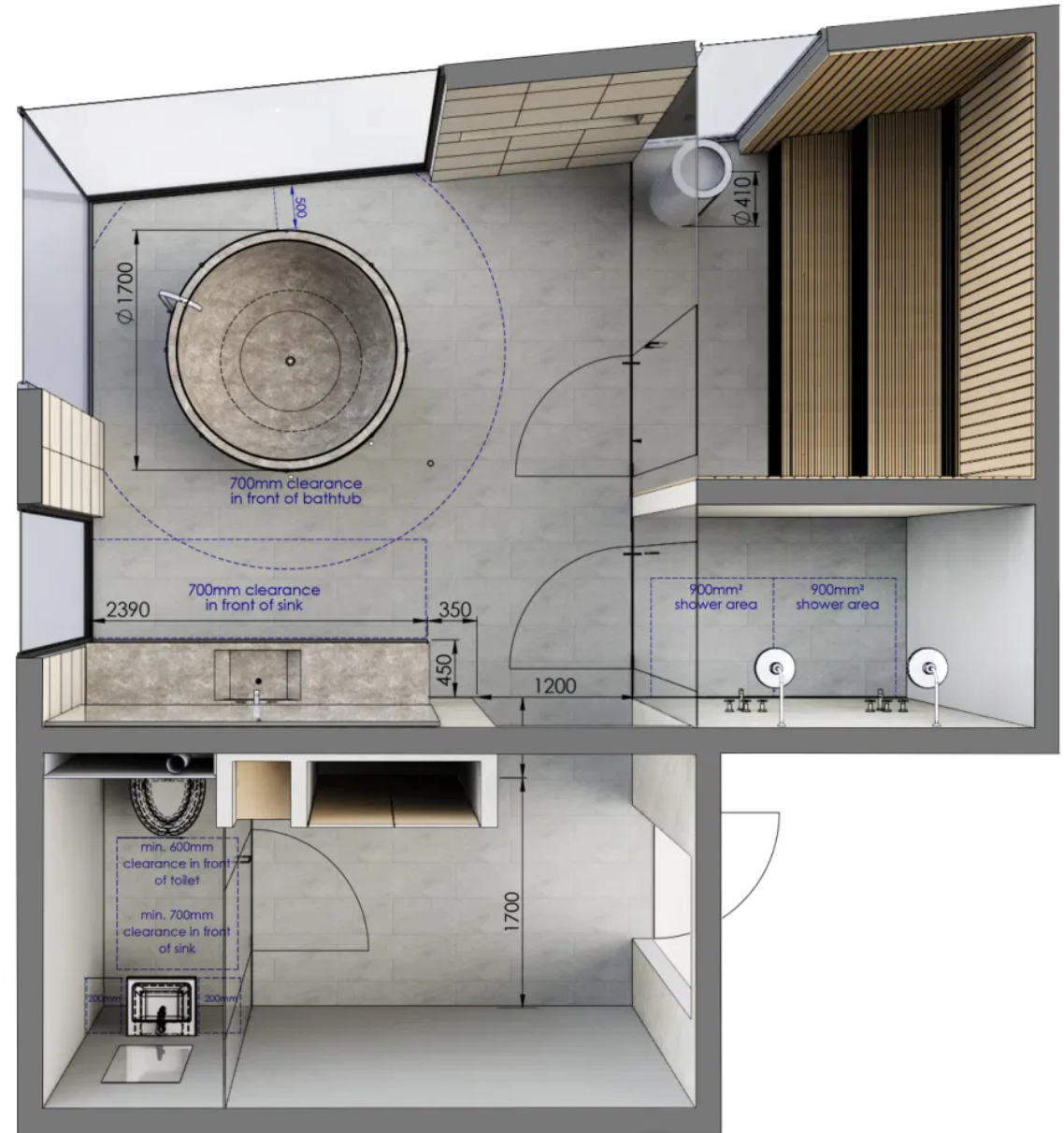

Figure - Bathroom Layout

(Source : <https://homedesigntutorials.com/2018/09/17/bathroom-design-principles/>)

### Objective 5 :

Identify design consideration of residential bathroom in term of floor drop level, circulation, arrangement of sanitary wares/ fittings floor finishes and wall finishes.

## 2.4 DESIGN CONSIDERATIONS

Design Considerations in Designing Bathroom

### III. SANITARY WARES & FITTING ARRANGEMENT

The key achieving maximum comfort and practicality in bathroom is the placement of sanitary wares and fitting arrangement. In this sub topic, we focus into four types of sanitary fittings:

BASIN

SHOWER

BATHTUB

WATER CLOSET

### Objective 5 :

Identify design consideration of residential bathroom in term of floor drop level, circulation, arrangement of sanitary wares/ fittings floor finishes and wall finishes.

## BASIN

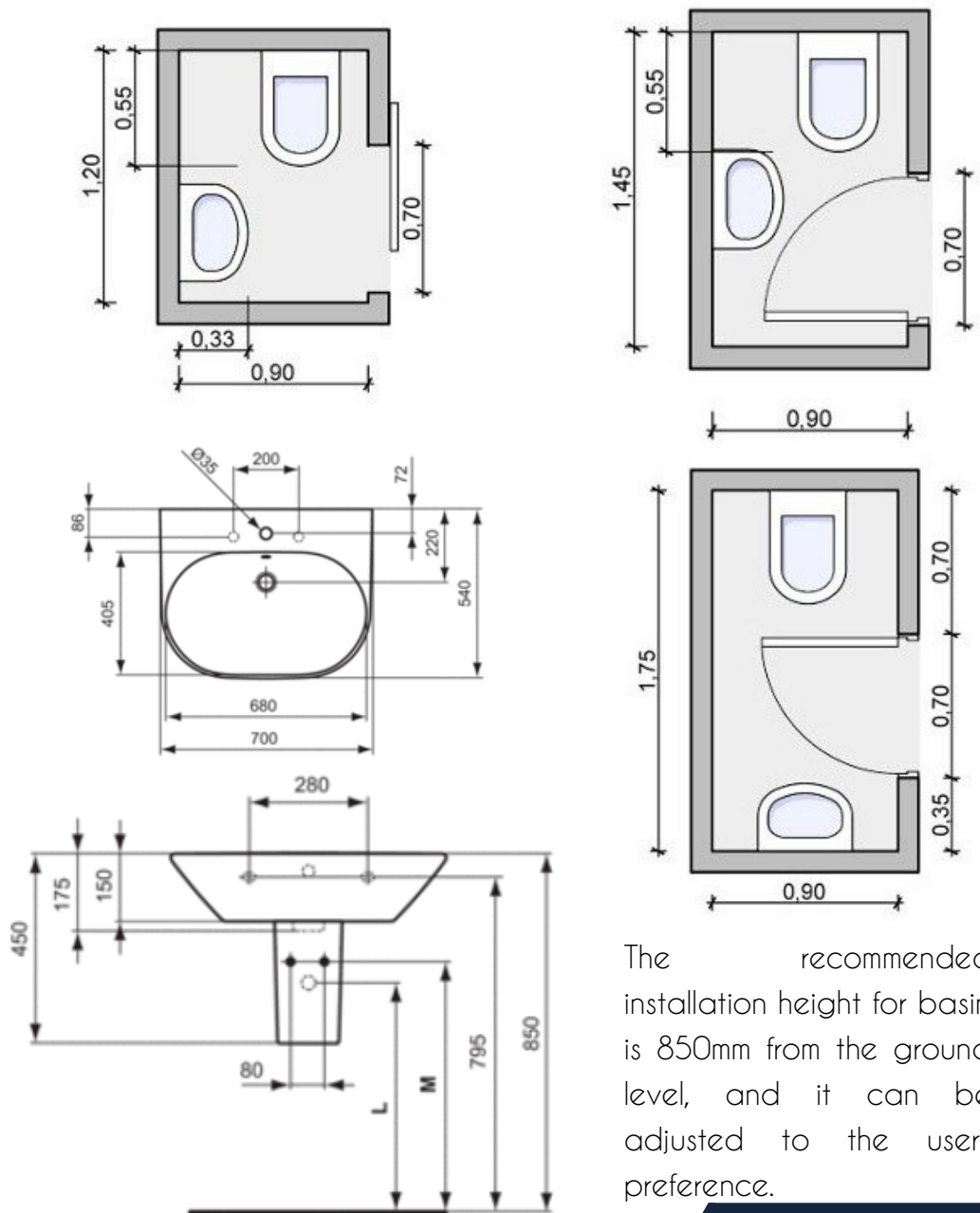

The recommended installation height for basin is 850mm from the ground level, and it can be adjusted to the users preference.

## 2.4 DESIGN CONSIDERATIONS

Design Considerations in Designing Bathroom

When designing a bathroom, users often face the dilemma of opting for the installation of either a shower or a bathtub. Functionality, space availability, sustainability, cost savings are main concerned during selecting the best bathroom fixture.

### SHOWER

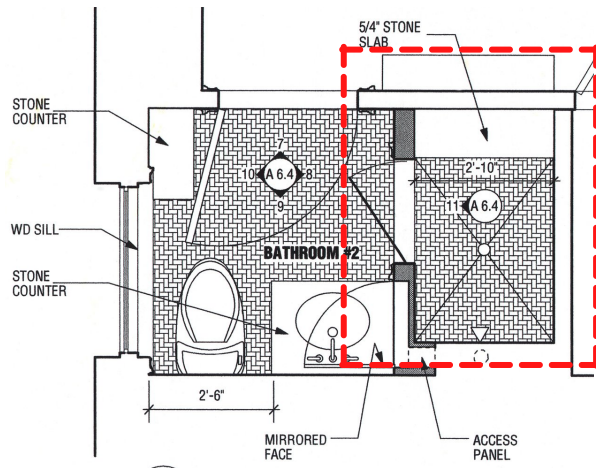

Shower is suitable for small bathroom space. It take up much less space than a bathtub. Installing shower reduce the water usage with two-third the amount of water of baths.

The most recommended layout is the three-in-a-row fittings (shower, basin and w.c).

### BATHTUB

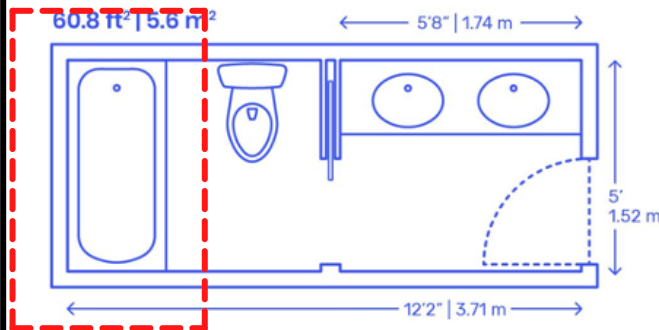

(Source : <https://www.dimensions.com>)

Installing bathtub in a bathroom can creates a versatile and luxury atmosphere. Housing development in Malaysia commonly use shower as installing a bathtub will increase the construction cost.

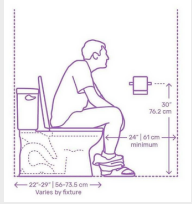

### WATER CLOSET

Bathroom tend to become a source of negative energy in a house especially when the water closet is facing the bathroom entrance. It can be a bad view if the bathroom is located in the master bedroom. Therefore, a bathroom layout can be influence by the culture context.

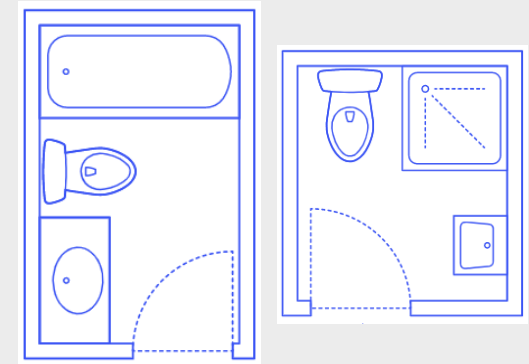

(Source : <https://www.dimensions.com>)

### Objective 5 :

Identify design consideration of residential bathroom in term of floor drop level, circulation, arrangement of sanitary wares/ fittings floor finishes and wall finishes.

## 2.4 DESIGN CONSIDERATIONS

Design Considerations in Designing Bathroom

### Objective 5 :

Identify design consideration of residential bathroom in term of floor drop level, circulation, arrangement of sanitary wares/ fittings floor finishes and wall finishes.

### IV. FLOOR & WALL FINISHES

Bathroom floor tiles is available with number of materials. The material is expected to protect and extend the life of the floor while provides attractive appearance and slip resistant. In this sub topic, a few material of bathroom finishes will be introduce for general information.



Ceramic tiles



Vinyl tiles

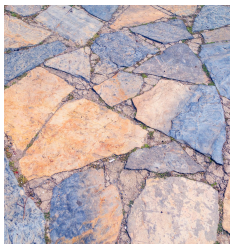

Natural stones

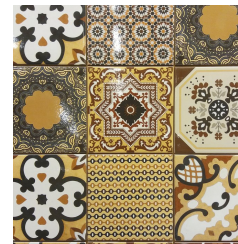

Porcelain tiles

## Bathroom Floor Finishes



### CERAMIC TILES

- Water resistant
- stone or wood lookalike
- Durable
- Works well with radiant heat

### PORCELAIN TILES

- Water Resistant
- Special tool cut
- Heavy
- Durable
- Works well with radiant heat
- (0.5% denser than ceramic)
- High cost

### NATURAL STONES

- Very Durable
- Expensive
- Cold under feet

### VINYL TILES

- Water resistant
- Cost-Effective
- Easy to cut
- Lighter (100% plastic)
- Comfortable when stepped on
- Reduce noise

### ENGINEERED WOOD

- Authentic hardwood on top
- Dimensional stability



### What to keep in mind?

Floor finishes must be:

- Anti-skid Properties
- Reducing water seepage

## 2.4 DESIGN CONSIDERATIONS

Design Considerations in Designing Bathroom

### IV. FLOOR & WALL FINISHES

Bathroom Wall Finishes



Main purpose of finishes is to covers the rough walls, ceilings and floor. Wall finishes is the final touch up given to the wall to enhance the interior or exterior look of the wall.

The pleasant and aesthetic décor is preferred for the best wall selection of bathroom. The basic design of the bathroom is determined by the appearance of the flooring and walls. In today's market, there is a large selection of bathroom wall finishing materials.

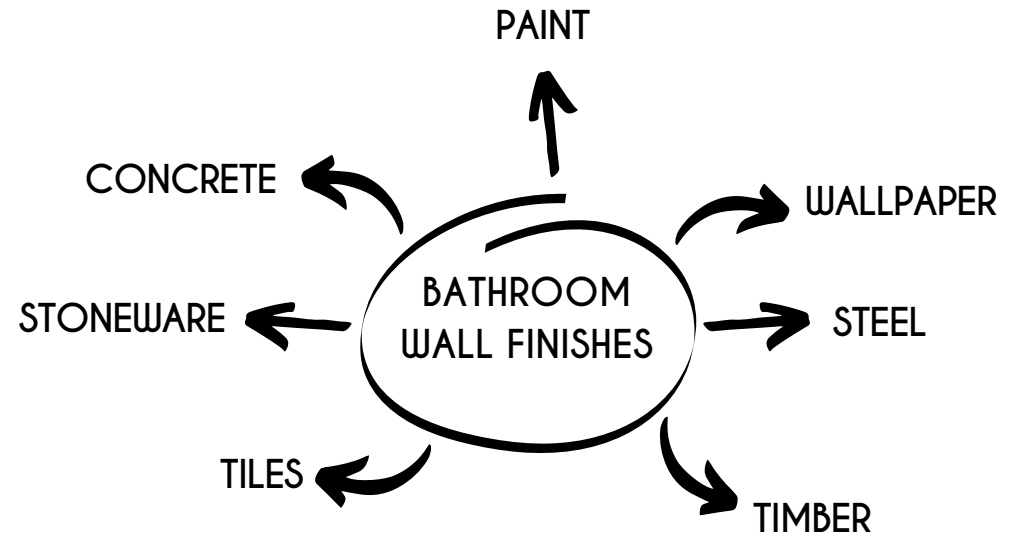

### Objective 5 :

Identify design consideration of residential bathroom in term of floor drop level, circulation, arrangement of sanitary wares/ fittings floor finishes and wall finishes.

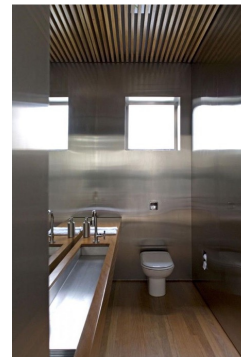

## 2.5 BATHROOM PLAN & SECTION (TASK 1)

You  
Tube

<https://youtu.be/uAqpWEfmDnl>

"STEP BY STEP ON  
HOW TO DRAW A  
BATHROOM PLAN &  
SECTION"

### Objective 6 :

Construct a drawing consists of a plan and section(s) of bathroom(s) for a house in compliance with Uniform Building by Laws, complete with label, dimension and specifications.

Sketch a plan and section of a toilet for residential building, the maximum area is four (4) square metre with appropriate drawing format with scale (1:10)

The drawings must be completed with the following information:

- Wall & Floor (section drawing/s)
- Sanitary fittings
- Opening (door and window)
- Labelling (space name, specification, drop & section symbol)
- Floor & wall finishes
- Dimension

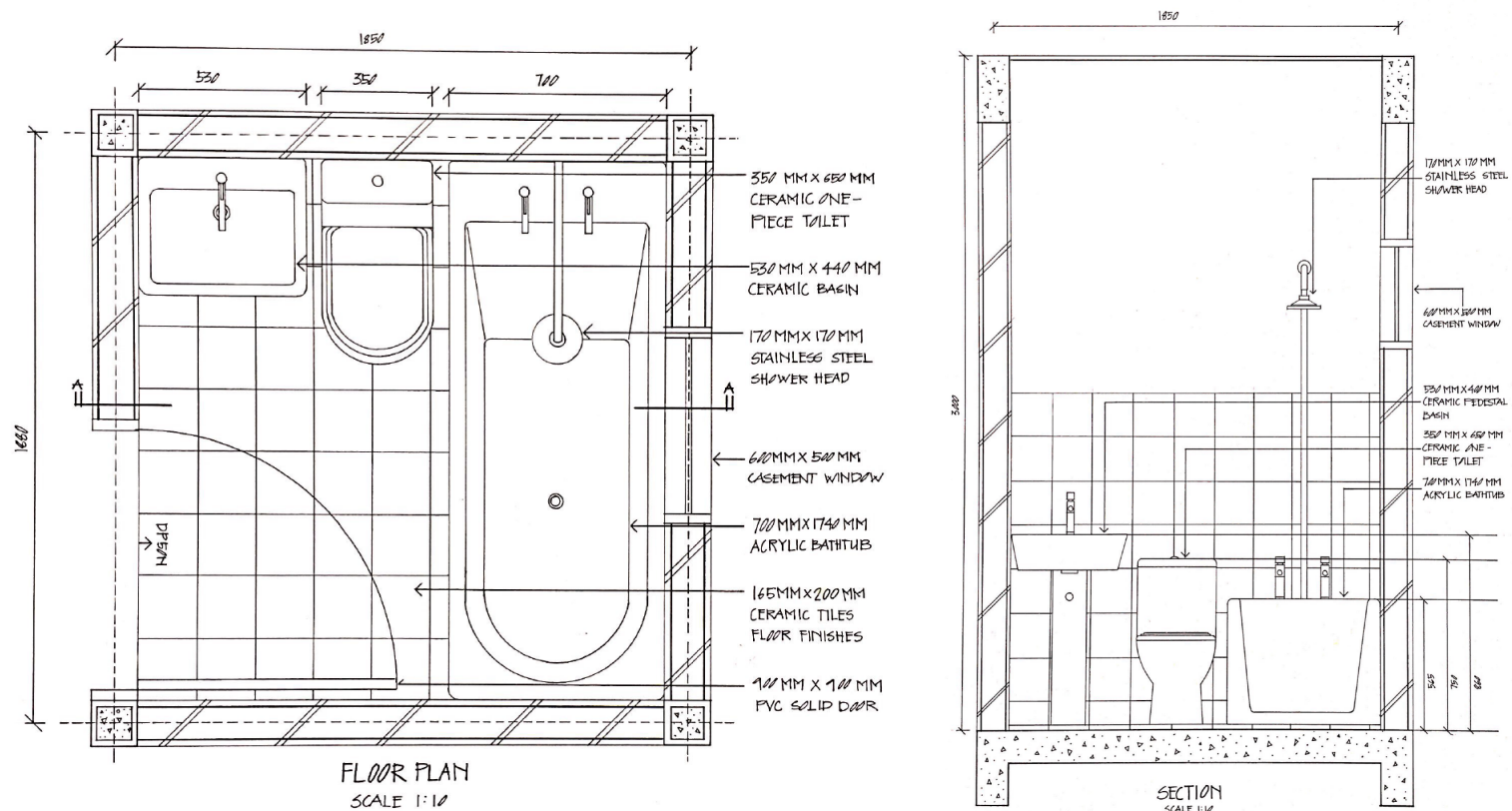
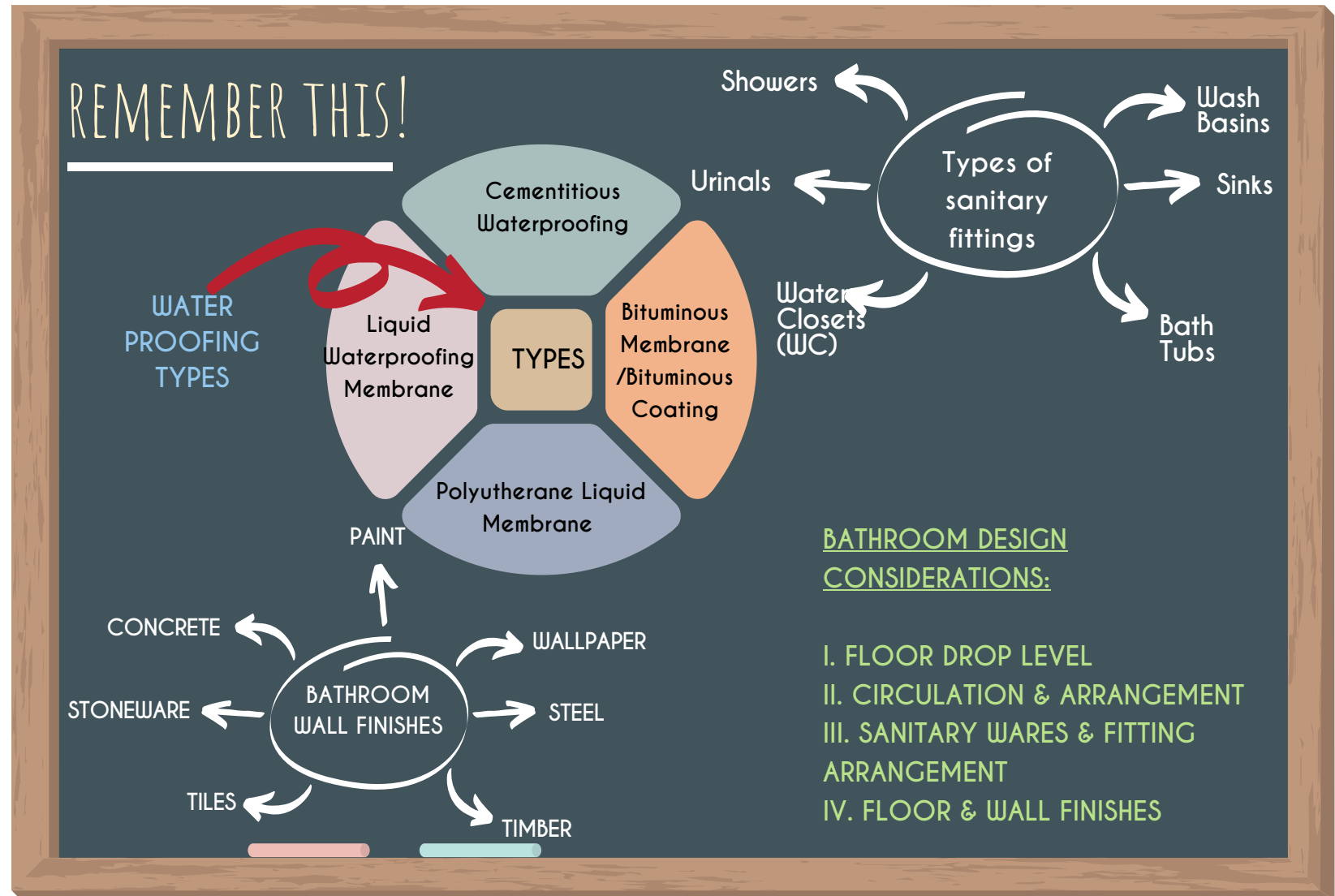

Figure : Example Drawing for Task 1



**TAKE QUIZ**



1. What is the Minimum width and height of a residential bathroom according to Uniform Building by Laws. (sect 2.1, pg.19)
2. Explain TWO (2) types of shower. (sect 2.2, pg.29)
3. Give FOUR (4) considerations for bathroom design. (sect 2.4, pg.34)

# CHAPTER 3 :

# RESTROOM DESIGN

- 3.0 Introduction
- 3.1 Uniform Building By-Law
- 3.2 Malaysia Standard
- 3.3 Universal Design
- 3.4 Layout Planning

## Main Objective :

Students will be able to analyze the design of selected public restroom in relations to the principles of Universal Design

## Focusing Subtopics

**Objective 1:**

- Explain minimum width and height of public restroom according to Uniform Building by Laws

**Objective 2 :**

Explain minimum openings for natural lighting and natural ventilation of public restroom according to Uniform Building by Laws

**Objective 3 :**

Identify the design considerations for public restroom as stated in the Malaysian Standard MS 2015-1:2017 (Public Toilets - Part 1 : Design Criteria)

**Objective 4 :**

Examine the layout planning and circulation of the selected public restroom in term of Universal Design for the elderly, parents with babies, children and disable people with diverse abilities: as well as the services and maintenance purposes

**Objective 5 :**

Analyze the provision of lighting and ventilation in the selected public restroom based on the openings.

**Objective 6 :**

Compare the findings to the requirement of MS 2015-1:2017 and UBBL and conclude the design considerations for public restroom.

**Main Objective :**

Analyze design of public restroom in relations to the principles of Universal Design



# 3.0 INTRODUCTION

Public restroom or commonly known as public toilets are spaces shared by people for urination and defecation which are located at malls, parks, petrol station, tourist sites, transport terminals, cinemas, Rest and Relaxation (R&R) and many more. It is accessible to all users, including people with disabilities, older people, and those with children. A good designed public restroom should be hygienic, welcoming and provide a high level of privacy to ensure all users feel comfortable. Public restroom should be designed according to the stated law and guidelines provided by local authorities.

Uniform Building by Laws (UBBL), Malaysian Standard and Universal Design principles are the key elements in this chapter.

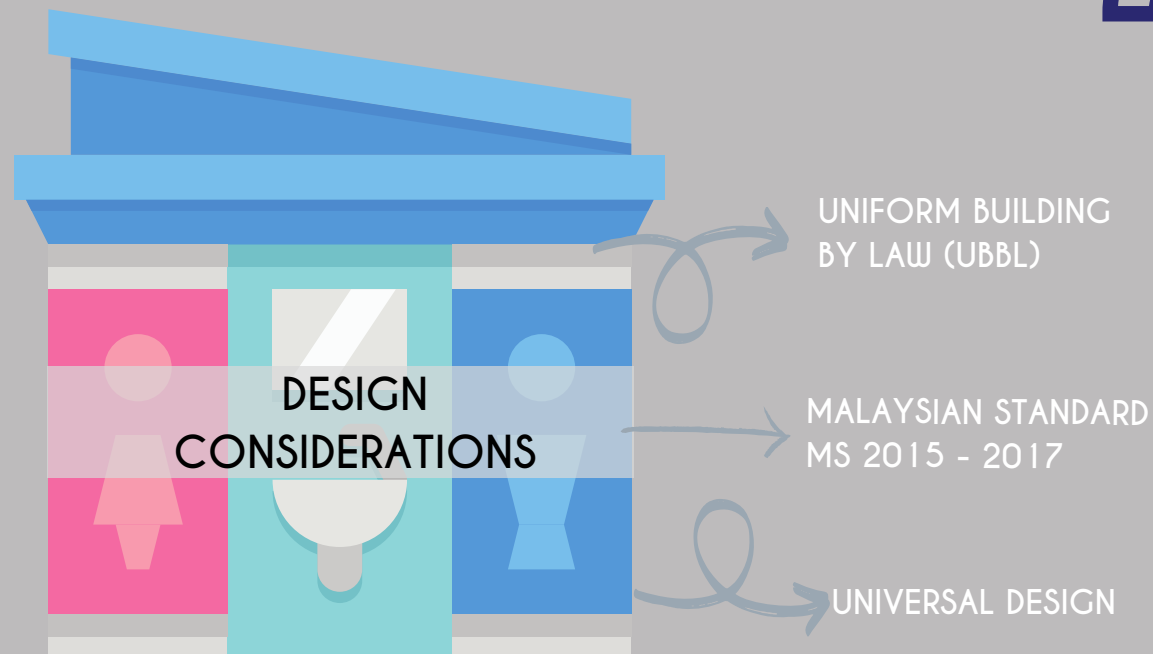
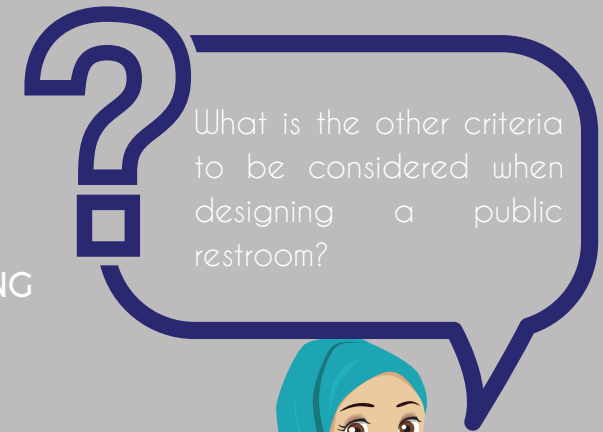

Figure - Public restroom



## 3.1

UNIFORM BUILDING  
BY LAW (UBBL)

## i. INTRODUCTION

Malaysia has established a building code, namely the Uniform Building By-Laws 1984 (UBBL 1984), enforced by the local authorities and applicable to all building types constructed in the local authorities' areas. It is subsidiary law under the Street Drainage and Building Act 1974 (Act 133). UBBL 1984 is a building code that provides minimum requirements for controlling and constructing streets, drainage, and building.

PART I - Preliminary

PART II - Submission of  
plan for approvalPART III - Space, light  
and ventilationPART IV - Temporary works in  
connection with building  
operationsPART V - Structural  
requirementsPART VI - Constructional  
requirementsPART VII - Fire  
requirementsPART VIII - Fire alarm, fire  
detection, fire extinguishment,  
& fire accessPART IX- Miscellaneous  
& Schedule

## ii. OBJECTIVE

The UBBL 1984 has a few defined aims, which are:

- Set a standardized building code for Malaysia that applies to all Local Authorities and building professionals,
- Establish a clear line of legal responsibility for buildings by defining the Principal Submitting Persons.
- Regulate architectural, structural, health & safety, fire protection capabilities and constructional requirements of buildings; with explicit references to the approved standards,
- Expedite the processing and building approvals and occupation of buildings



What are the advantages of having a uniform by-laws?

### 3.1 UNIFORM BUILDING BY LAW (UBBL)

#### PART III

Space, Light &  
Ventilation

By Law 30-47

#### Objective 1 :

Explain minimum width and height of public restroom according to Uniform Building by Laws

### iii. MINIMUM DIMENSIONS OF LATRINE, WATER-CLOSETS AND BATHROOMS

By-Law 43:

In all buildings, the sizes of latrine, water-closets and bathrooms shall be:

- in the case of latrines or water-closets with pedestal-type closet fittings, not less than 1.5 metres by 0.75 metre;
- in the case of water-closets with fittings other than pedestal-type closet fittings, not less than 1.25 metres by 0.75 metre;
- in the case of bathrooms, not less than 1.5 square metres with a width of not less than 0.75 metre; and
- in the case of bathrooms with closet fittings, not less than 2 square metres with a width of not less than 0.75 metre.

source: Uniform Building By-Law

	Toilets	Area
1	Water closet with pedestal-type	1.5 m x 0.75 m
2	Water closet other than pedestal-type	1.25 m x 0.75m
3	Bathrooms	1.5 m <sup>2</sup> (Width not <0.75)
4	Bathrooms with close fittings	2 m <sup>2</sup> (Width not <0.75)

Table - Minimum areas as stated in UBBL

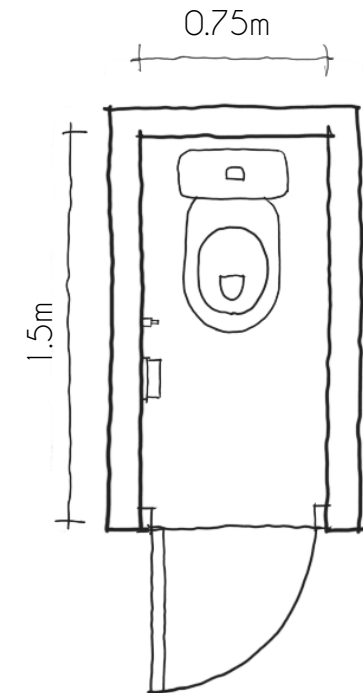

Figure - Minimum width of toilet

### 3.1 UNIFORM BUILDING BY LAW (UBBL)

#### PART III

Space, Light &  
Ventilation

By Law 30-47

#### Objective 2 :

Explain minimum openings for natural lighting and natural ventilation of public restroom according to Uniform Building by Laws

#### iv. HEIGHT OF ROOMS

By-Law 46:

(1) In building other than those specified in the preceding provisions of by-laws 44 and 45 the height of rooms on the ground floor shall not be less than 3 metres and on any floor above the ground floor shall not be less than 2.75 metres.

source: Uniform Building By-Law

#### v. NATURAL LIGHTING AND VENTILATION

Room layout

By-Law 39 (1): Every room designed, adapted or used for residential, business or other purposes except hospitals and schools shall be provided with natural lighting and natural ventilation by means of one or more windows having a total area of not less than 10% of the clear floor area of such room and shall have openings capable of allowing a free uninterrupted passage of air of not less than 5% of such floor area.

Bathroom layout

By-Law 39 (4): Every water-closet, latrine, urinal or bathroom shall be provided with natural lighting and natural ventilation by means of one or more openings having a total area of not less than 0.2 square metre per water-closet, urinal latrine or bathroom and such openings shall be capable of allowing a free uninterrupted passage of air.

source: Uniform Building By-Law

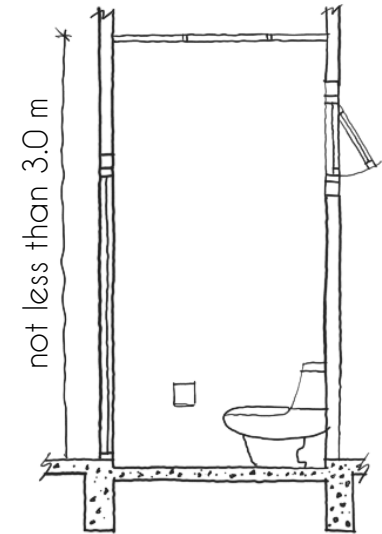

Figure - Minimum height of toilet

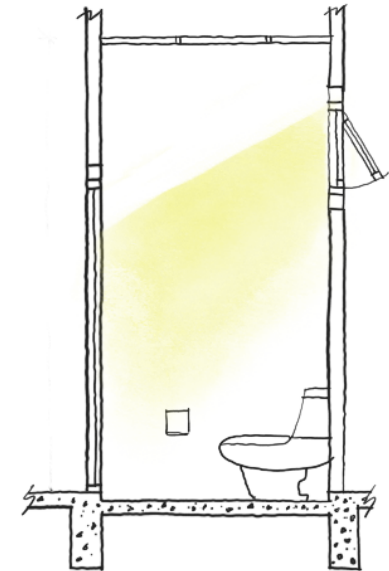

Figure - Natural lighting and ventilation

### 3.1 UNIFORM BUILDING BY LAW (UBBL)

#### • CALCULATION FOR PERCENTAGE OF NATURAL LIGHTING

##### 1. PROVIDED:

$$\frac{\text{Total number of window} \times \text{window area} \times 100\%}{\text{Floor area}}$$

Example:

$$\frac{3 \times 0.6\text{m} \times 0.6\text{m} \times 100\%}{7\text{m} \times 4.5\text{m}} = \frac{1.08}{31.5\text{sqm}} \times 100\% = 3.43\% \checkmark$$

##### 2. REQUIRED (UBBL) :

floor area x 10% (lighting)

Example:

$$7\text{m} \times 4.5\text{m} (\text{floor area}) \times 10\% (\text{lighting}) = 31.5\text{sqm} \times 10\% = 3.15\%$$

The % PROVIDED must exceed or more than % REQUIRED by UBBL!

Hence, 3.43% > 3.15%

In conclusion, this public restroom design complies with Uniform Building by Law (UBBL) because it has exceeded the minimum openings for natural lighting.

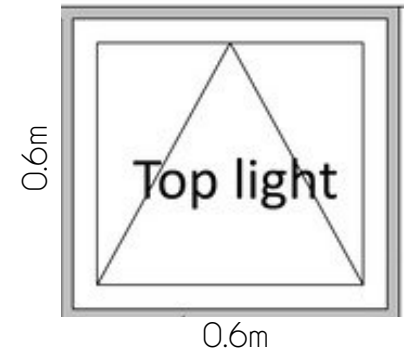

Figure - Size of window

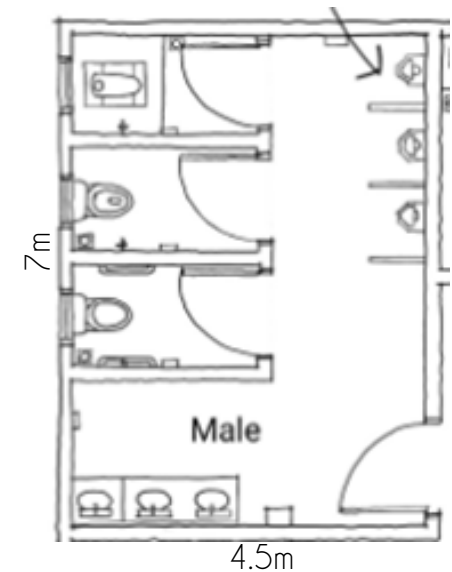

Figure - Size of public restroom

#### Objective 2 :

Explain minimum openings for natural lighting and natural ventilation of public restroom according to Uniform Building by Laws

### 3.1 UNIFORM BUILDING BY LAW (UBBL)

#### • CALCULATION FOR PERCENTAGE OF NATURAL VENTILATION

##### 1. PROVIDED:

$$\frac{\text{Total number of window} \times \text{window area} \times 100\%}{\text{Floor area}}$$

Example:

$$\frac{3 \times 0.6\text{m} \times 0.6\text{m} \times 100\%}{7\text{m} \times 4.5\text{m}} = \frac{1.08}{31.5\text{sqm}} \times 100\% = 3.43\% \checkmark$$

##### 2. REQUIRED (UBBL) :

floor area x 5% (ventilation)

Example:

$$7\text{m} \times 4.5\text{m} \text{ (floor area)} \times 5\% \text{ (ventilation)} = 31.5\text{sqm} \times 5\% = 1.58\%$$

The % PROVIDED must exceed or more than % REQUIRED by UBBL!

Hence, 3.43% > 1.58%

In conclusion, this public restroom design complies with Uniform Building by Law (UBBL) because it has exceeded the minimum openings for natural ventilation.

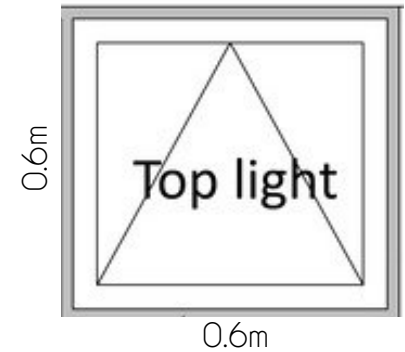

Figure - Size of window

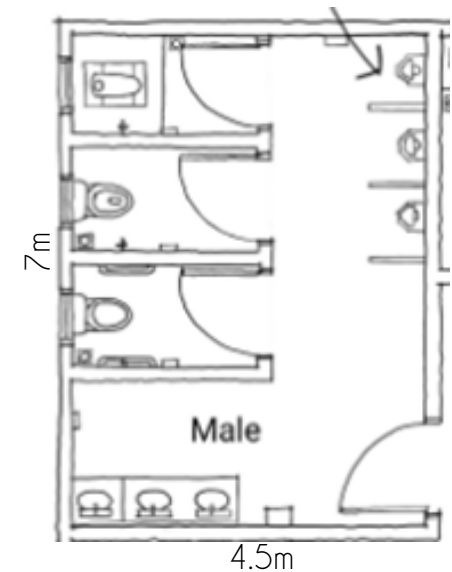

Figure - Size of public restroom

#### Objective 2 :

Explain minimum openings for natural lighting and natural ventilation of public restroom according to Uniform Building by Laws

### 3.1 UNIFORM BUILDING BY LAW (UBBL)

- TABLE FOR PERCENTAGE OF NATURAL LIGHTING VENTILATION (EXAMPLE)

Bil.	Ruang (Space)	Luas Lantai (m2) Floor Area (sqm)	Pencahayaann Lighting		Pengudaraan Ventilation	
			Diperlukan Required (min 10% of total area)	Disediakan Provided	Diperlukan Required (min 5% of total area)	Disediakan Provided
1.	Tandas Lelaki <i>Male Toilet</i>	31.5	3.15	3.43	1.08	3.43
2.	Tandas Wanita <i>Female Toilet</i>	31.5	3.15	3.43	1.08	3.43
3.	Tandas OKU <i>OKU toilet</i>	4.8	0.48	0.6	0.24	0.6

Percentage of PROVIDED  
natural lighting Must be  
MORE than the REQUIRED  
natural lighting by UBBL.  
(10% of total area)

Percentage of PROVIDED  
natural ventilation Must  
be MORE than the  
REQUIRED natural  
ventilation by UBBL. (5% of  
total area)

#### Objective 2 :

Explain minimum openings for natural lighting and natural ventilation of public restroom according to Uniform Building by Laws

## 3.2 MALAYSIAN STANDARDS

### i. INTRODUCTION

The Department of Standards Malaysia (STANDARDS MALAYSIA) under the Ministry of Science, Technology and Innovation (MOSTI), is the National Standards and Accreditation Body.

The main function of the Standards Department of Malaysia is:

- to stimulate and encourage standards, standardization and accreditation as a way to advance the country's economy,
- promoting efficiency and development of industries that are beneficial to health and public safety,
- consumer protection, facilitating domestic trade and international as well as extending international cooperation in relation to standards and standardization.
- The Malaysian Standard (MS) was developed with the approval of the committees which is made up of a balanced representation of manufacturers,
- consumers and others whose interests are relevant, as appropriate to the matter at hand worked on.
- Malaysian Standard is in line with or adopted from the international standard, as much as possible. Approval of a standard as Malaysian Standard is defined by the Malaysian Standard Act 1996 [Act 549].
- Malaysian Standard is under review regularly. The use of the Malaysian Standard is voluntary, unless required by regulatory authorities through regulations, by-laws local or any other similar way.

source: [www.jsm.gov.my](http://www.jsm.gov.my)

**STANDARDS  
MALAYSIA**

The benefits of Malaysian Standard:

- Consumer protection and public welfare.
- Standards specify the minimum requirements of quality, health and safety including areas involving the environment and occupational safety, reliability and quality to consumers.
- Terminology and symbol standards help in better understanding.

source: [www.jsm.gov.my](http://www.jsm.gov.my)



### Objective 3 :

Identify the design considerations for public restroom as stated in the Malaysian Standard MS 2015-1:2017 (Public Toilets - Part 1 : Design Criteria)

## 3.2 MALAYSIAN STANDARDS

MS 2015-1 : 2017

### ii. OBJECTIVE

The objective of Malaysian Standard is to assist in providing clean, hygienic, safe and convenient-to-use public toilet facilities of appropriate design and quality and provide guidelines on primary care and maintenance.

### iii. MS 2015

MS 2015 consists of the following parts, under the general title public toilets;

- Part 1: MINIMUM DESIGN CRITERIA
- Part 2: INSPECTION CRITERIA
- Part 3: RATING CRITERIA
- Part 4: CODE OF PRACTICE FOR MAINTENANCE

### iv. USERS

#### Objective 3 :

Identify the design considerations for public restroom as stated in the Malaysian Standard MS 2015-1:2017 (Public Toilets - Part 1 : Design Criteria)

#### 1. LOCAL AUTHORITIES

e.g:

- City Council / City Hall
- Municipal Council
- District Council

#### 2. GOVERNMENT DEPARTMENTS

e.g:

- Ministry of Housing and Local Government

#### 3. PROVIDERS OF PUBLIC TOILETS

Consultants, Designers, Builders, Toilet Facility Provider, and those who are involved in the building industry



Figure - Front page of MS 2015-1:2017

## 3.2 MALAYSIAN STANDARDS

MS 2015-1 : 2017

### Objective 3 :

Identify the design considerations for public restroom as stated in the Malaysian Standard MS 2015-1:2017 (Public Toilets - Part 1 : Design Criteria)

#### v. MS 2015-1 : 2017 (PUBLIC TOILETS – PART 1 : DESIGN CRITERIA)

MS 2015-1 : 2017 consists of:

- Scope
- Normative references
- Terms and definitions
- Performance requirements
- Design of public toilet
- Location
- Number of toilet units
- Expectations of users



#### vi. DESIGN CONSIDERATIONS

##### Safety / security

Public restrooms and their entrances must be visible to the general public and must not be hidden.

##### Privacy

Users will be able to do personal hygiene and grooming activities in the privacy of their own.

##### Hygiene

Users must have access to a hygienic environment that is unlikely to cause infection, disease or clothing soiling.

##### Equality

Public restrooms must be accessible to all potential users, regardless of gender or physical activity.

##### Convenience

Convenience of use of public toilets.

##### Vandal resistance

Public restrooms must be resistant to vandalism to stay available for use and create a pleasant environment.

### 3.3 UNIVERSAL DESIGN

#### i. INTRODUCTION

Universal Design is the process of designing so that it can be accessed to all type of user, regardless of age, disability or other factors. It is a philosophy that emphasize social responsibility and no discrimination in the built environment.

The Seven Principles of Universal Design were developed by group of architects, product designers, engineers and environmental design researchers in 1997 as a guidelines for accessible design.

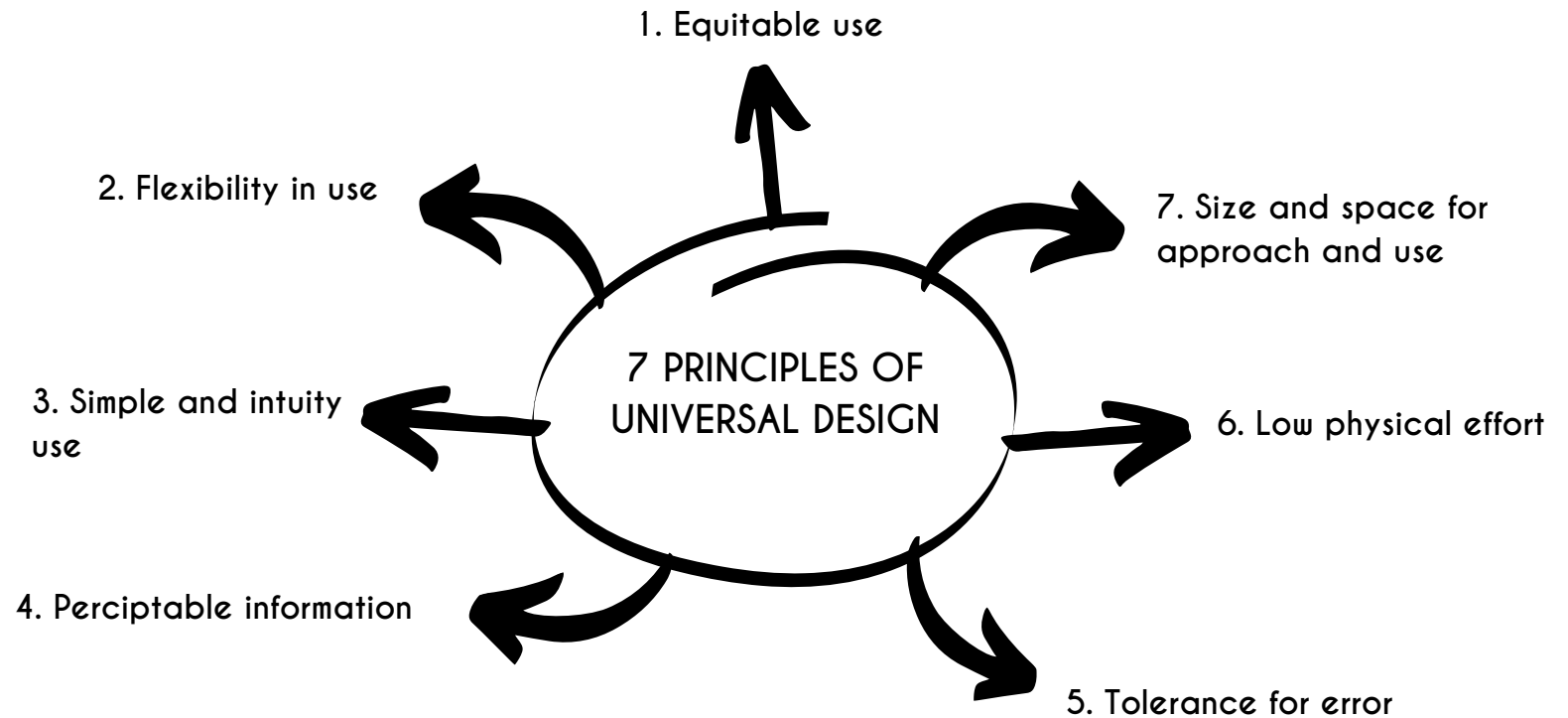

#### Objective 4 :

Examine the layout planning and circulation of the selected public restroom in term of Universal Design for the elderly, parents with babies, children and disable people with diverse abilities: as well as the services and maintenance purposes

### 3.3 UNIVERSAL DESIGN

#### Guidelines

#### Objective 4 :

Examine the layout planning and circulation of the selected public restroom in term of Universal Design for the elderly, parents with babies, children and disable people with diverse abilities: as well as the services and maintenance purposes

PLAN Malaysia (the Federal Department of Town and Country Planning) has developed a guideline 'Garis Panduan Perancangan Reka Bentuk Sejagat' to assist the State Authority, Local Planning Authority and government agencies in planning and designing facilities and built environment that accessible by all people, regardless of age, disability or other factors.

The guidelines include minimum requirements in designing public restroom accessible to disable people:

a) Toilets for disabled shall be provided in public and commercial buildings, recreational areas, public places and public transport terminals.

b) The number of toilets and the design requirements shall follow clauses 16, 17, 18, 19, 20, 22 and 26 MS1184:2002 [Clause 18.13, MS 1331:2003] and MS 2015: Part 1:2006.

c) The minimum number of toilets equipped with facilities for wheelchair users is 1 for every 10 regular toilets [Clause 5.5, MS2015: Part 1: 2006] and the minimum size of the toilet is 2000mm x 2400mm. Minimum size for other users is 1200mm x 2400 mm and comes with a grab bar.

d) The toilet symbols for male and female should embossed or written in braille for guidance to the visually impaired [Clause 28.7, MS 1184: 2202].

(Adapted from GPP Rekabentuk Sejagat on PLANMalaysia 2011)

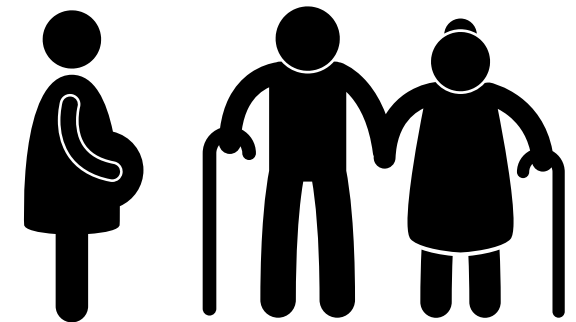

3.3  
UNIVERSAL DESIGN

Guidelines

Objective 4 :

Examine the layout planning and circulation of the selected public restroom in term of Universal Design for the elderly, parents with babies, children and disable people with diverse abilities: as well as the services and maintenance purposes

ACCESSIBLE LAYOUT

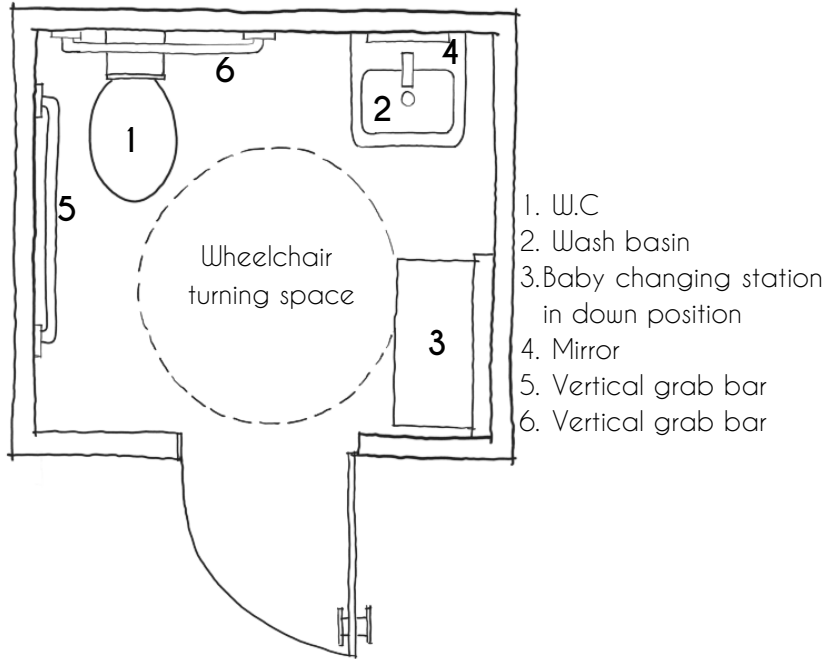

Figure - Example of accessible toilet

URINALS

Urinals for children use shall be provided at 450mm height above floor finished level (MS 2015-1 : 2017).

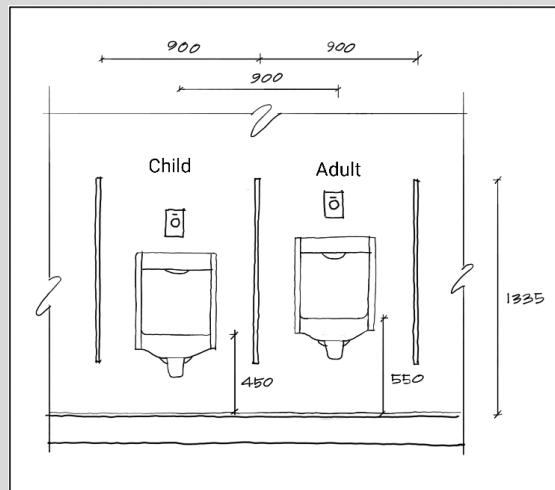

Figure - Urinal standard (source : MBPJ (modified))

WASH BASIN

Wash basin for children use shall be provided at 600mm height above floor finished level (MS 2015-1 : 2017).

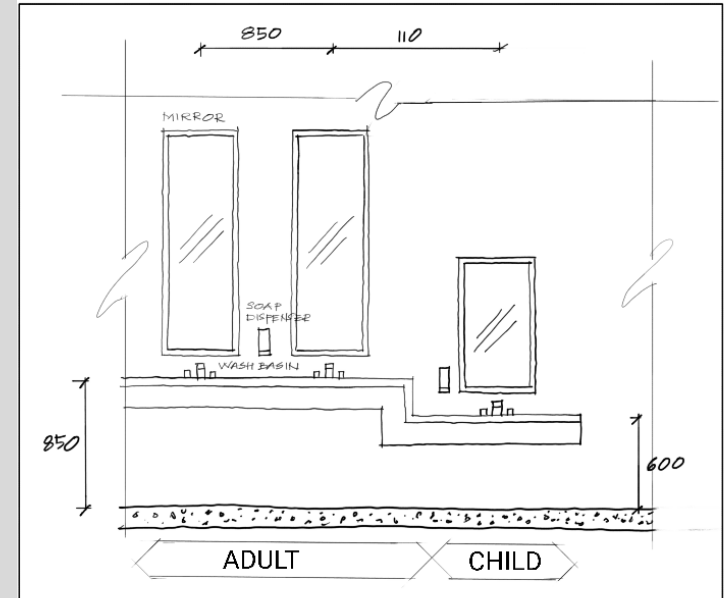

Figure - Wash basin standard (source : MBPJ (modified))



Figure - Universal design for wash basin (source : changiairport.com)

3.3

UNIVERSAL DESIGN

Guidelines

Objective 4 :

Examine the layout planning and circulation of the selected public restroom in term of Universal Design for the elderly, parents with babies, children and disable people with diverse abilities: as well as the services and maintenance purposes

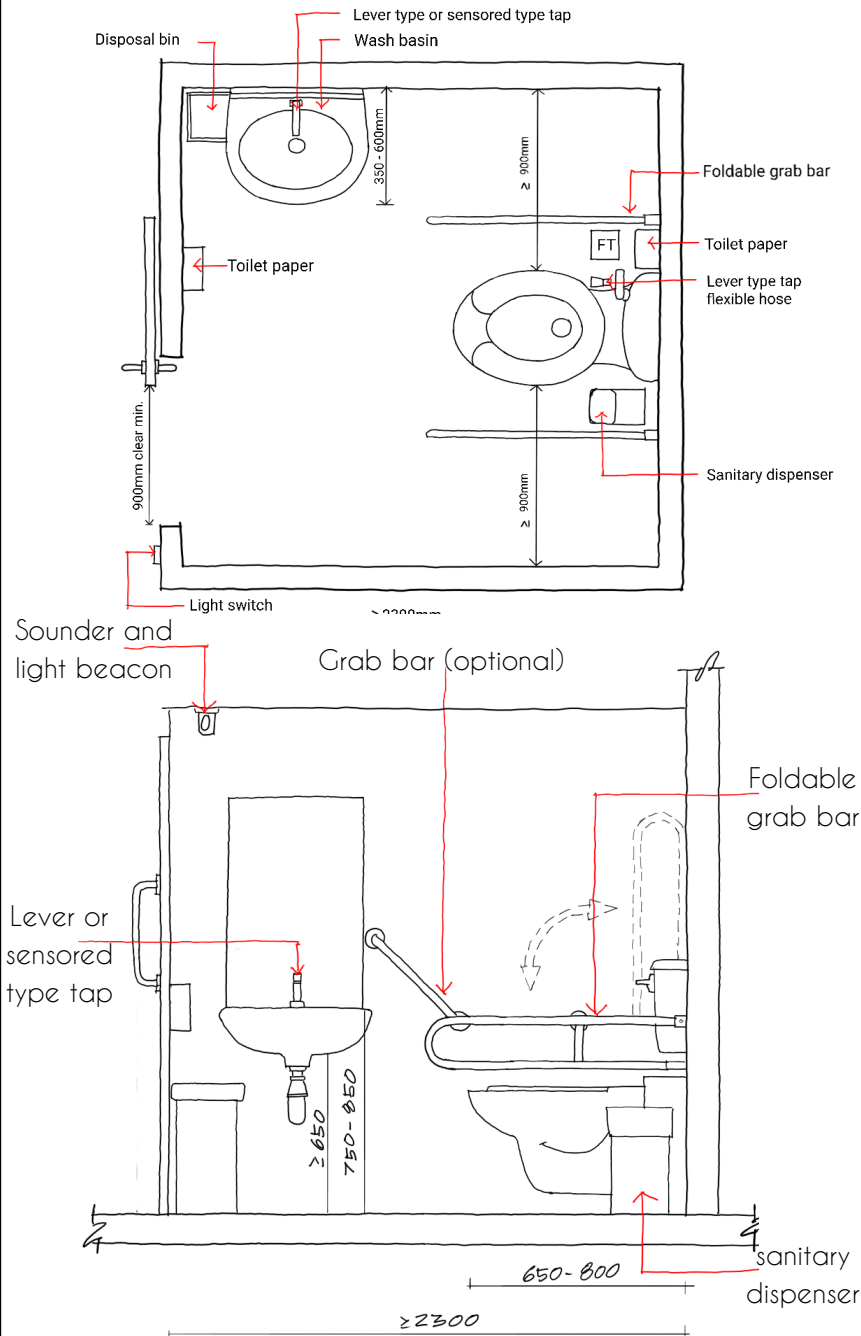

Figure - Plan and section layout for disabled toilet  
source : MBPJ (modified)

DISABLED TOILET

Disabled toilet shall be provided in public buildings, commercial buildings, recreational areas, public transport terminals according to the guidelines provided by MS 2015-1 : 2007

Number of toilet provided	Number of accessible toilet
1 - 10	1
11 - 20	2
21 - 30	3

Toilet fittings must be according to the disabled guidelines specifications and dimension to meet the needs of the target group.

- Disabled toilets can be integrated with other cubicles or to be design seperately.
- Minimum illuminance is 200 lux measured at 800mm from above floor finishes level.
- Anti-slip and non-glossy materials for floor finishes.
- 1500mm x 1500mm clearance between w.c and wash basin.
- Sliding door with minimum 900mm width.

source : MBPJ

## 3.4

## LAYOUT PLANNING

## Objective 4 :

Examine the layout planning and circulation of the selected public restroom in term of Universal Design for the elderly, parents with babies, children and disable people with diverse abilities: as well as the services and maintenance purposes

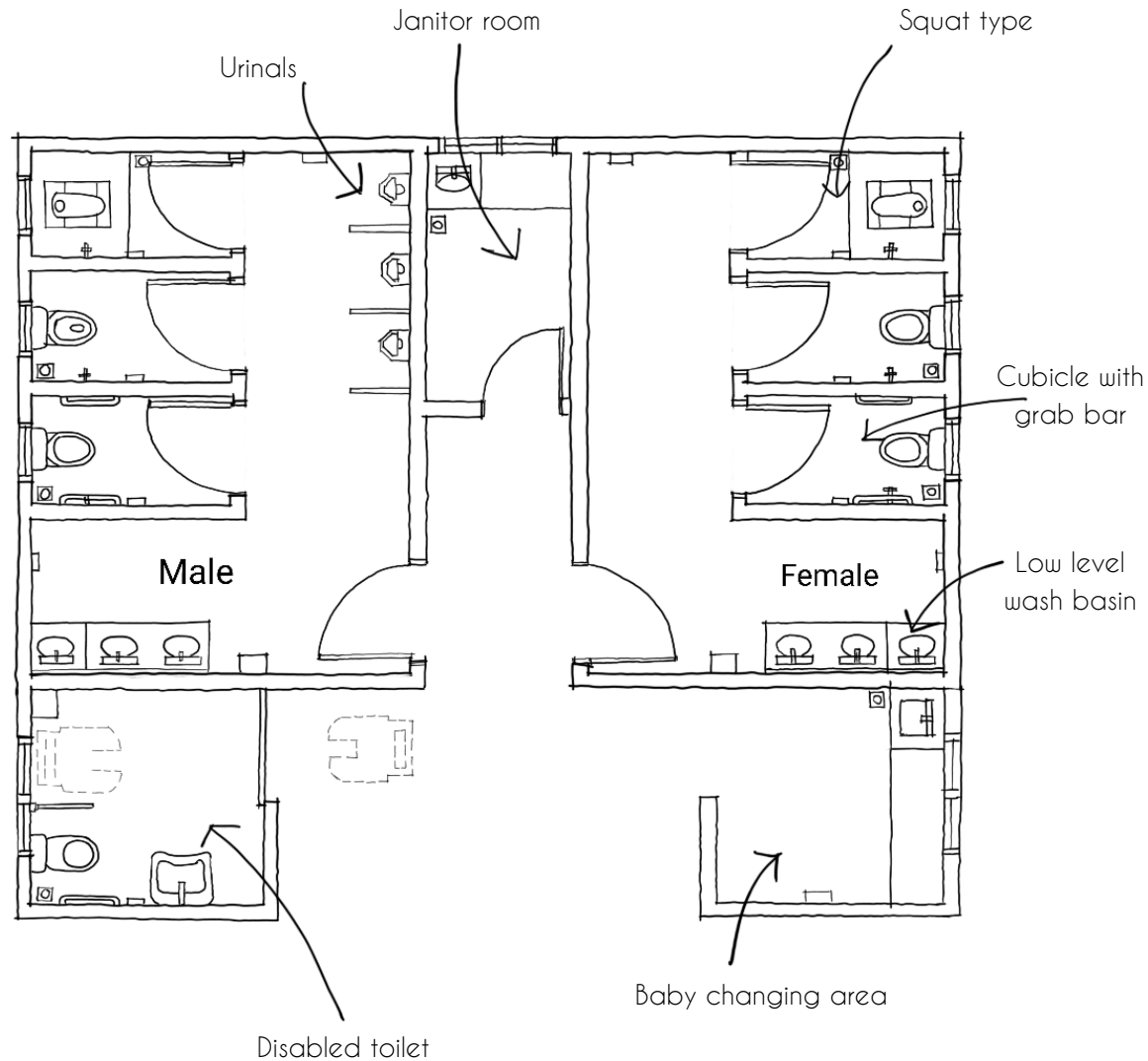

Figure : Example layout of public restroom

Minimum dimension of toilet cubicle shall be 1200mm x 1800 mm measured from wall tiles surface.

Cubicle layout and other facilities provided should be easy to see and provides personal privacy to users.

If only one disabled toilet is provided, the toilet must be located outside, attached to the public restroom.

Baby changing area shall be provided adjacent to the female toilets.

A urinal for children shall be provided at an appropriate height

Floor traps shall be provided in all cubicles and outside the cubicles area.

(Garis Panduan Reka Bentuk Bilik Air Awam di Seluruh Negara)

## CONCLUSION

Public bathrooms are locations where people are forced to relieve themselves in unfamiliar surroundings with strangers of the same sex. Regardless of age, size, ability, or disability, all building users should have access to these amenities. It should be designed to accommodate kids and adults of various ages, sizes, and abilities. Most significantly, the design of a public toilet should adhere to the UBBL 1984. Meanwhile, the Malaysian Standard document ensures that public restrooms are designed to be clean, hygienic, safe, and convenient.

## CASE STUDY

### Objective 5 :

Analyze the provision of lighting and ventilation in the selected public restroom based on the openings.

### Objective 6 :

Compare the findings to the requirement of MS 2015-1:2017 and UBBL and conclude the design considerations for public restroom

Identify a public restroom available in your area and conduct an investigation. You are required to analyse the design of public restroom following the criteria:

- The Universal Design Considerations
- Layout planning
- Circulation
- Services and maintenance
- Lighting
- Ventilation

Identify if the public restroom meet the requirements of UBBL 1984 and MS 2015-1 : 2017. From your findings, compare the requirement differences of UBBL 1984 and MS 2015-1 : 2017. finally, you must provide suggestion for improvement.



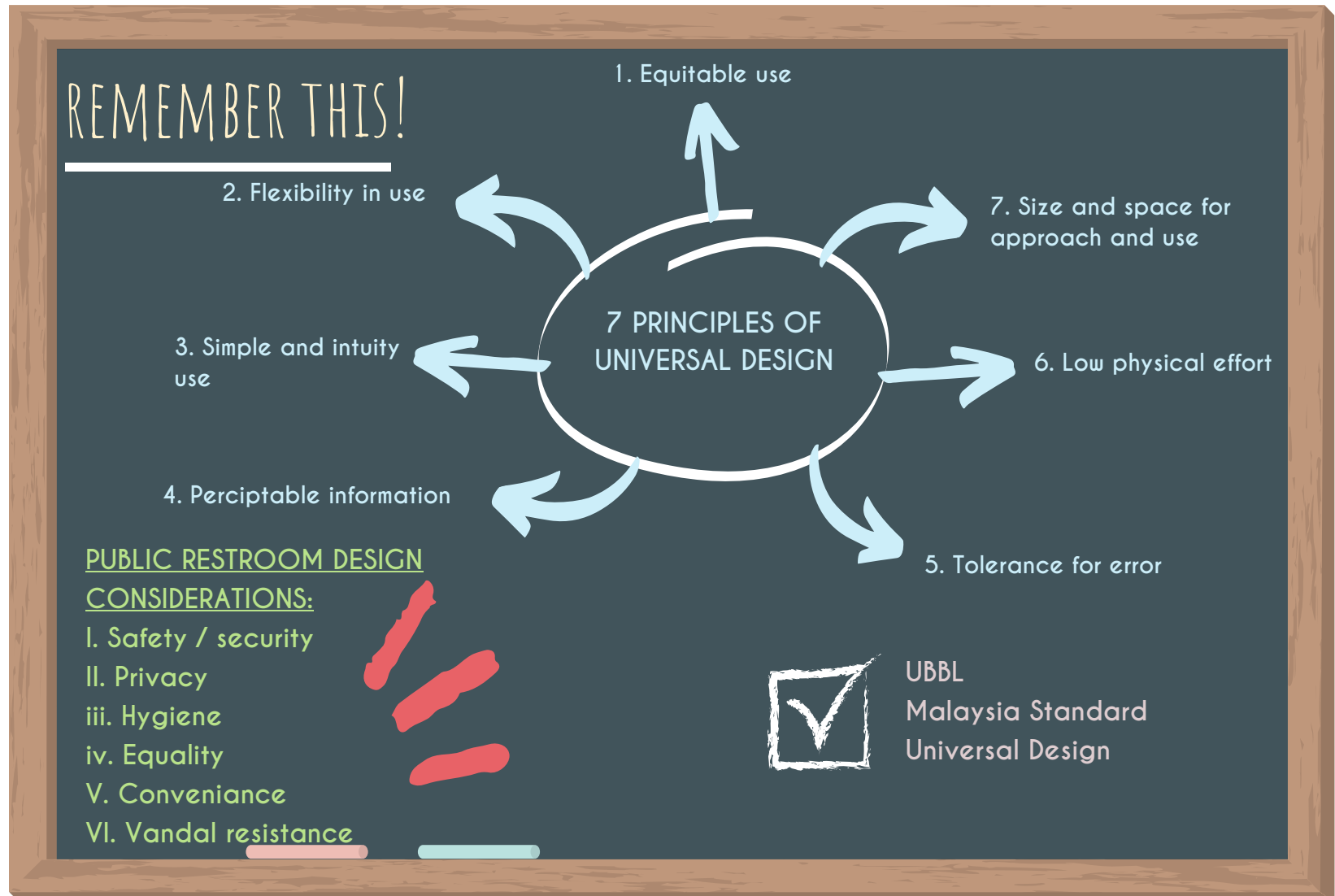

**TAKE QUIZ**



1. Explain minimum openings for natural ventilation of public restroom according to Uniform Building by Law. (sect 3.1, pg.47)
2. Explain the objective of Malaysian Standard? (sect 3.2, pg.49)
3. What is the suitable height of Wash basin for children use shall be provided according to MS 2015-1 : 2017. (sect 3.3, pg.53)

## REFERENCES

ASEAN Public Toilet Standard. (2016, January).Website. [www.asean.org](http://www.asean.org)

BaDa. (2021, Jan 21). How To Draw Bathroom Plan & Section (Task 1) [Video]. YouTube. <https://www.youtube.com/watch?v=uAqpWEfmDnl>

BaDa. (2021, Mar16). Architecture Layer Book~How to Draw Water Supply Diagram and SPAH Diagram for Architecture Student [Video]. YouTube. <http://www.youtube.com/watch?v=rYdM493az7I>

Dimensions.com (2021) Website. <https://www.dimensions.com>

Garis Panduan Reka Bentuk Bilik Air (Kubikel Tandas & Kubikel Mandi) Awam Di Seluruh Negara. (Cawangan Arkitek, IPJKR), 2006

Garis Panduan Reka Bentuk Sejagat Petaling Jaya. Majlis Bandaraya Petaling Jaya, 2019

Hall, F., & Greeno, R. (2017). Building services handbook. Routledge.

Official website of Department of Standards Malaysia. [www.jsm.my](http://www.jsm.my)

Uniform Building by Law (1984) Pindaan 2016. MALAYSIA: International Law Book Services, International Law Book Services (ILBS)



# BUILDING SERVICES

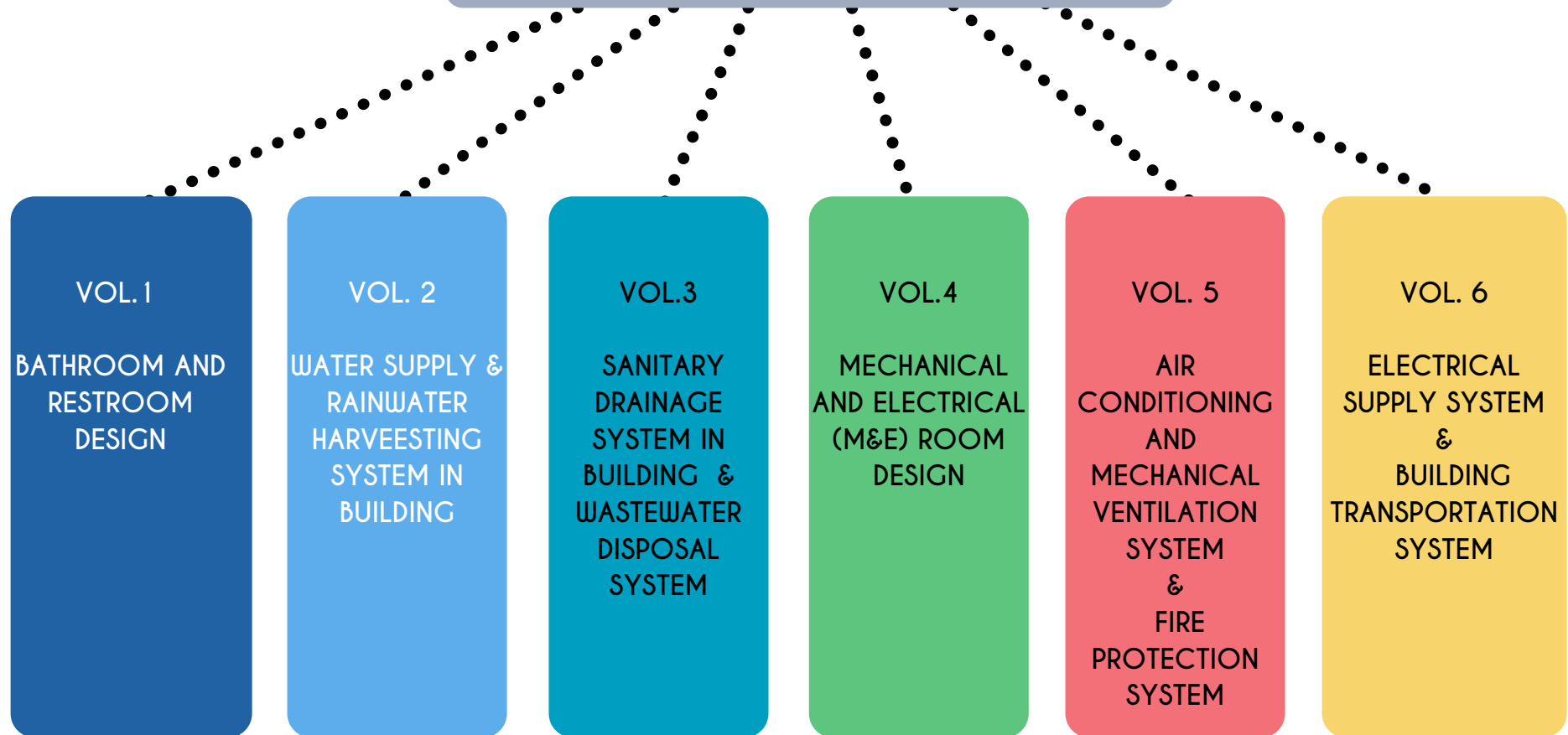

THE END

e ISBN 978-967-2897-22-4



9 7 8 9 6 7 2 8 9 7 2 2 4

BUILDING SERVICES  
VOL. 1