

SULIT



**KEMENTERIAN PENDIDIKAN TINGGI
JABATAN PENDIDIKAN POLITEKNIK DAN KOLEJ KOMUNITI**

**BAHAGIAN PEPERIKSAAN DAN PENILAIAN
JABATAN PENDIDIKAN POLITEKNIK DAN KOLEJ KOMUNITI
KEMENTERIAN PENDIDIKAN TINGGI**

JABATAN MATEMATIK, SAINS DAN KOMPUTER

PEPERIKSAAN AKHIR

SESI I : 2025/2026

DBS10042: ENGINEERING SCIENCE

TARIKH : 22 NOVEMBER 2025

MASA : 8.30 PAGI – 10.30 PAGI (2 JAM)

Kertas ini mengandungi **SEBELAS (11)** halaman bercetak.

Struktur (4 soalan)

Dokumen sokongan yang disertakan : Formula

JANGAN BUKA KERTAS SOALAN INI SEHINGGA DIARAHKAN

(CLO yang tertera hanya sebagai rujukan)

SULIT

INSTRUCTION:

This section consists of **FOUR (4)** structured questions. Answer **ALL** questions.

ARAHAN:

Bahagian ini mengandungi EMPAT (4) soalan berstruktur. Jawab SEMUA soalan.

QUESTION 1**SOALAN 1**

- CLO1 (a) Define the following terms with **TWO (2)** examples:
Takrifkan terma berikut berserta DUA(2) contoh:
- i. base quantity.
kuantiti asas.
- [3 marks]
[3 markah]
- ii. vector quantity.
kuantiti vektor.
- [3 marks]
[3 markah]
- CLO1 (b) Change the following units:
Tukarkan unit yang berikut:
- i. 1.97 km/min to m/s
1.97 km/min kepada m/s
- [3 marks]
[3 markah]
- ii. 0.975 gcm^{-3} to kgm^{-3}
 0.975 gcm^{-3} kepada kgm^{-3}
- [3 marks]
[3 markah]

- iii. 0.3048 m/s^2 to km/hr^2
 0.3048 m/s^2 kepada km/hr^2

[3 marks]

[3 markah]

CLO1

- (c) Write the actual reading for the following:

Tuliskan bacaan sebenar bagi yang berikut:

- i. if the zero error of the vernier caliper is -0.03 cm .
jika ralat sifar angkup vernier adalah -0.03 cm .

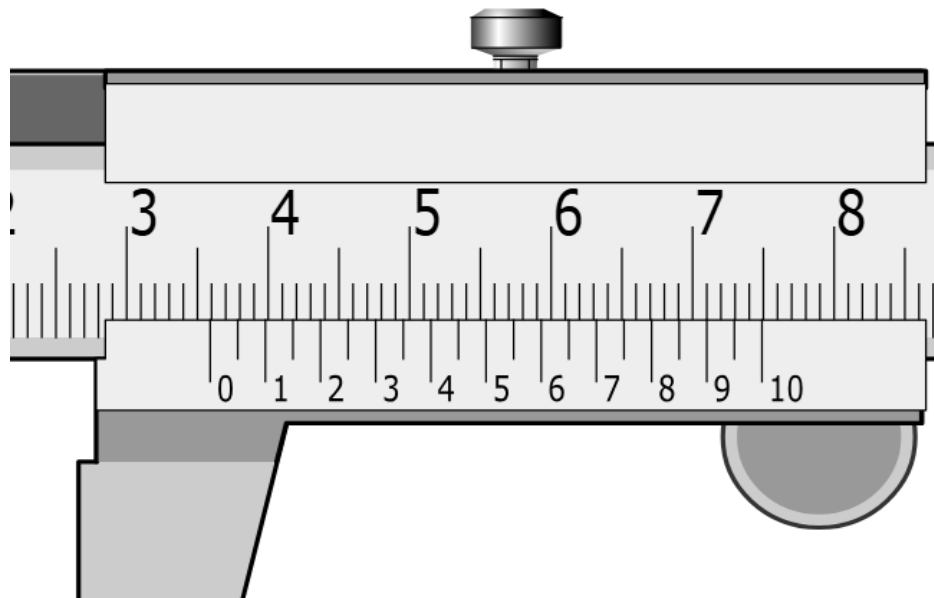

Figure 1(c)i./ *Rajah 1(c)i.*

[5 marks]

[5 markah]

- ii. if the zero error is 0.05 mm.
jika ralat sifar adalah 0.05 mm.

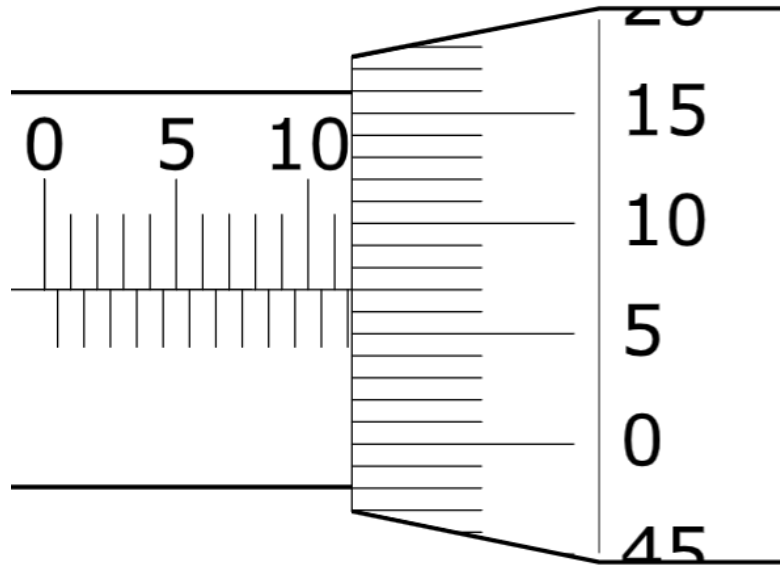

Figure 1(c)ii./ *Rajah 1(c)ii.*

[5 marks]

[5 markah]

QUESTION 2

SOALAN 2

- CLO1 (a) i. Define uniform motion with **TWO (2)** examples.
*Takrifkan gerakan seragam berserta **DUA (2)** contoh.*
- [3 marks]
[3 markah]
- ii. Give **TWO (2)** differences between speed and velocity.
*Berikan **DUA (2)** perbezaan antara laju dan halaju.*
- [4 marks]
[4 markah]
- CLO1 (b) A car with constant acceleration 0.5 m/s^2 moves initially 60 m/s in 120 second. Calculate the:
Sebuah kereta dengan pecutan malar 0.5 m/s^2 bergerak dengan halaju awal 60 m/s dalam 2 minit. Kirakan:
- i. final velocity in **m/s**
*halaju akhir dalam **m/s***
- [4 marks]
[4 markah]
- ii. distance travelled in meter, **m**
*jarak yang dilalui dalam meter, **m***
- [4 marks]
[4 markah]

- CLO1 (c) Figure 2c(i) shows a motorcycle moves in a straight road. Its velocity increases from 12 m/s to 32 m/s in 10 seconds. It then maintains its velocity for 6 seconds before coming to rest in 4 seconds.

Rajah 2c(i) menunjukkan sebuah motosikal bergerak pada satu jalan lurus. Halajunya bertambah dari 12 m/s kepada 32 m/s dalam masa 10 saat. Ia kemudian mengekalkan halajunya selama 6 saat sebelum berhenti dalam masa 4 saat.

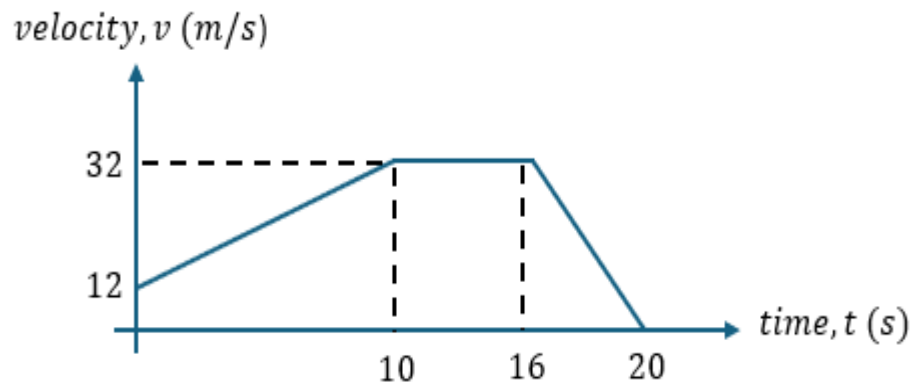

Figure 2(c)i./Rajah 2(c)i.

- i. Calculate the acceleration and deceleration of the motorcycle.
Kirakan pecutan dan nyahpecutan motosikal tersebut.

[6 marks]

[6 markah]

- ii. Calculate the total distance travelled.
Kirakan jumlah jarak yang dilalui.

[4 marks]

[4 markah]

QUESTION 3**SOALAN 3**

- CLO1 (a) i. Define potential energy and its SI unit.
Takrifkan tenaga keupayaan dan unit SI nya.
- [2 marks]
[2 markah]
- ii. Define power and its SI unit.
Takrifkan kuasa dan unit SI nya.
- [2 marks]
[2 markah]
- iii. State **FOUR (4)** types of renewable energy.
*Senaraikan **EMPAT (4)** jenis tenaga yang diperbaharui.*
- [4 marks]
[4 markah]
- CLO1 (b) Nazrin with a mass of 80 kg hiked to the peak of a hill 95 m above the street level. The time required to reach the peak is 480 seconds.
Nazrin dengan jisim 80 kg mendaki puncak bukit pada ketinggian 95 m daripada aras jalan. Masa yang diperlukan untuk ke puncak adalah 480 saat.
- i. Calculate the work done by Nazrin.
Kirakan kerja yang dilakukan oleh Nazrin.
- [4 marks]
[4 markah]
- ii. Calculate the power produced by Nazrin.
Kirakan kuasa yang dihasilkan oleh Nazrin.
- [4 marks]
[4 markah]

- CLO1 (c) In a volleyball match, Nasuha makes a serve with a volleyball that has a mass of 0.2806 kg. The ball moves with a speed of 30 m/s and reaches highest position of 5 m.
- Dalam perlawanan bola tampar, Nasuha membuat servis dengan bola tampar yang berjisim 0.2806 kg. Bola tersebut bergerak dengan kelajuan 30 m/s dan mencapai kedudukan tertinggi 5 m.*
- i. Calculate the kinetic energy (E_K) and potential energy (E_P) of the ball.
Kirakan tenaga kinetik (E_K) dan tenaga keupayaan (E_P) bola tersebut.
- [6 marks]
[6 markah]
- ii. Calculate the total energy of the ball (E_T).
Kirakan jumlah tenaga bola tersebut (E_T).
- [3 marks]
[3 markah]

QUESTION 4**SOALAN 4**

- CLO1 (a) i. List **TWO (2)** characteristics of solids, liquid and gases.
Senaraikan DUA (2) ciri-ciri pepejal, cecair dan gas.
- [6 marks]
[6 markah]
- ii. State the definition and the SI unit of temperature.
Nyatakan definisi dan unit SI bagi suhu.
- [2 marks]
[2 markah]
- CLO1 (b) i. An aquarium with dimensions of $0.9 \text{ m} \times 1.2 \text{ m} \times 0.7 \text{ m}$ has a mass of 8.4 kg. Calculate the density of the block.
Sebuah blok dengan dimensi $0.9 \text{ m} \times 1.2 \text{ m} \times 0.7 \text{ m}$ mempunyai jisim 8.4 kg. Kirakan ketumpatan blok tersebut.
- [3 marks]
[3 markah]

- ii. Figure 4(b)ii shows a basic hydraulic system. A load of mass m (kg) is placed on the larger piston, which has a cross-sectional area of 0.4 m^2 . Calculate the mass of the load required to maintain equilibrium if the pressure is 9810 N/m^2 .

Rajah 4(b)ii menunjukkan satu sistem hidraulik asas. Satu beban berjisim m (kg) diletakkan pada omboh yang lebih besar, yang mempunyai luas keratan rentas 0.4 m^2 . Kirakan jisim beban yang diperlukan untuk mengekalkan keseimbangan jika tekanan ialah 9810 N/m^2 .

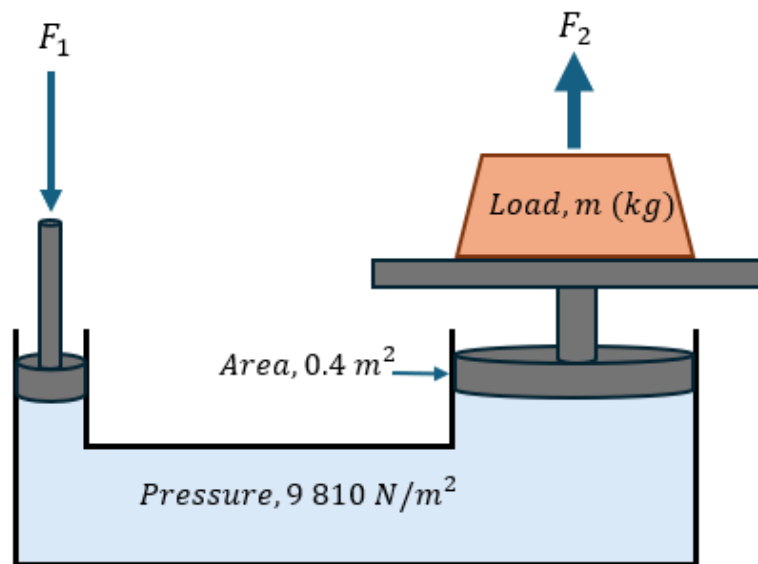

Figure 4(b)ii./Rajah 4(b)ii.

[5 marks]

[5 markah]

- CLO1 (c) i. Calculate the quantity of heat required to raise the temperature of 0.7 kg of sulfuric acid from 20°C to 70°C. (Given: specific heat capacity of sulfuric acid, $c_{\text{sulfuric}} = 1.42 \text{ kJ / kg}^\circ\text{C}$).
- Kirakan kuantiti haba yang diperlukan untuk menaikkan suhu 0.7 kg asid sulfurik daripada 20°C kepada 70°C. (Diberi: haba tentu asid sulfurik, $c_{\text{sulfurik}} = 1.42 \text{ kJ / kg}^\circ\text{C}$).*
- [3 marks]
[3 markah]
- ii. A brass plate of mass 1.2 kg is heated in an oven to 98°C. It is then transferred into 2.5 kg of water at 30°C. Determine the final temperature when thermal equilibrium is reached. Assume no heat loss to the surroundings.
- (Given the specific heat capacity of brass plate, $c_{\text{brass}} = 380 \text{ kJ / kg}^\circ\text{C}$ and specific heat capacity of water, $c_{\text{water}} = 4200 \text{ kJ / kg}^\circ\text{C}$).
- Satu plat Loyang berjisim 1.2 kg dipanaskan di dalam ketuhar sehingga mencapai suhu 98°C. Plat Loyang tersebut kemudian dimasukkan ke dalam 2.5 kg air yang bersuhu 30°C. Tentukan suhu akhir apabila keseimbangan terma tercapai. Anggapkan tiada kehilangan haba ke persekitaran.*
- (Diberi haba tentu bagi plat loyang, $c_{\text{loyang}} = 380 \text{ kJ / kg}^\circ\text{C}$ dan haba tentu bagi air, $c_{\text{air}} = 4200 \text{ kJ / kg}^\circ\text{C}$)*
- [6 marks]
[6 markah]

SOALAN TAMAT

**FORMULA DBS10042
ENGINEERING SCIENCE**

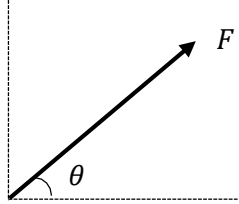
$g = 9.81 \text{ m/s}^2$	$W = F \times d$
$w = mg$	$W = mgh$
$v = u + at$	$W = Fd \cos \theta$
$s = ut + \frac{1}{2}at^2$	$F_x = F \cos \theta$
$s = \frac{1}{2}(u + v)t$	$F_y = F \sin \theta$
$v^2 = u^2 + 2as$	 $F_R = \sqrt{(\sum F_x)^2 + (\sum F_y)^2}$ $\theta = \tan^{-1}\left(\frac{F_y}{F_x}\right)$
$F = ma$	
$F_g = mg$	
$F = mg \sin \theta$	$P = \frac{W}{t}$
$\rho = \frac{m}{V}$	$P = F \times v$
$\rho_{\text{relative}} = \frac{\rho_{\text{substance}}}{\rho_{\text{water}}}$	$P = \rho gh$
$M = F \times d$	$P = \frac{F}{A}$
$E_p = mgh$	$\frac{F_1}{A_1} = \frac{F_2}{A_2}$
$E_k = \frac{1}{2}mv^2$	$A_1h_1 = A_2h_2$
$\text{Efficiency} = \frac{P_{\text{output}}}{P_{\text{input}}} \times 100\%$	$F_B = \rho Vg$
$\text{Efficiency} = \frac{E_{\text{output}}}{E_{\text{input}}} \times 100\%$	$Q = mc\Delta\theta$
$\text{Efficiency} = \frac{W_{\text{output}}}{W_{\text{input}}} \times 100\%$	$Q = mL$
$\rho_{\text{water}} = 1000 \text{ kg/m}^3$	$C_{\text{water}} = 4200 \text{ J/kg}^\circ\text{C}$

Length, Area, Mass, and Volume Conversion

Length		
1 inch (in)		2.54 centimeter (cm)
1 foot (ft)	12 inches (in)	30.48 centimeter (cm)
1 yard (yd)	3 feet (ft)	0.9144 meter (m)
1 mile (mi)	1,760 yards (yd)	1.60934 kilometer (km)
Area		
1 in ²		6.4516 cm ²
1 ft ²		0.09 m ²
1 yd ²	9 ft ²	0.8361 m ²
1 acre	4,840 yd ²	4046.86 m ² / 0.405 hectare
1 mile ²	640 acres	2.590 km ²
Mass (weight)		
1 ounce (oz)		28.35 grams (g)
1 pound (lb.)		453.59 grams (g)
Volume		
1 gallon (gal)		3.8 liters (L)
1 ft ³		0.03 m ³
1 yd ³		0.76 m ³

Temperature Conversion

Temperature	
Convert Fahrenheit (F) to Celsius (C)	$(\text{degrees F} - 32) \times 0.555$
Convert Celsius (C) to Fahrenheit (F)	$(\text{degrees C} \times 1.8) + 32$