

ENGINEERING SCIENCE

VOLUME 1
(CHAPTER 1-3)

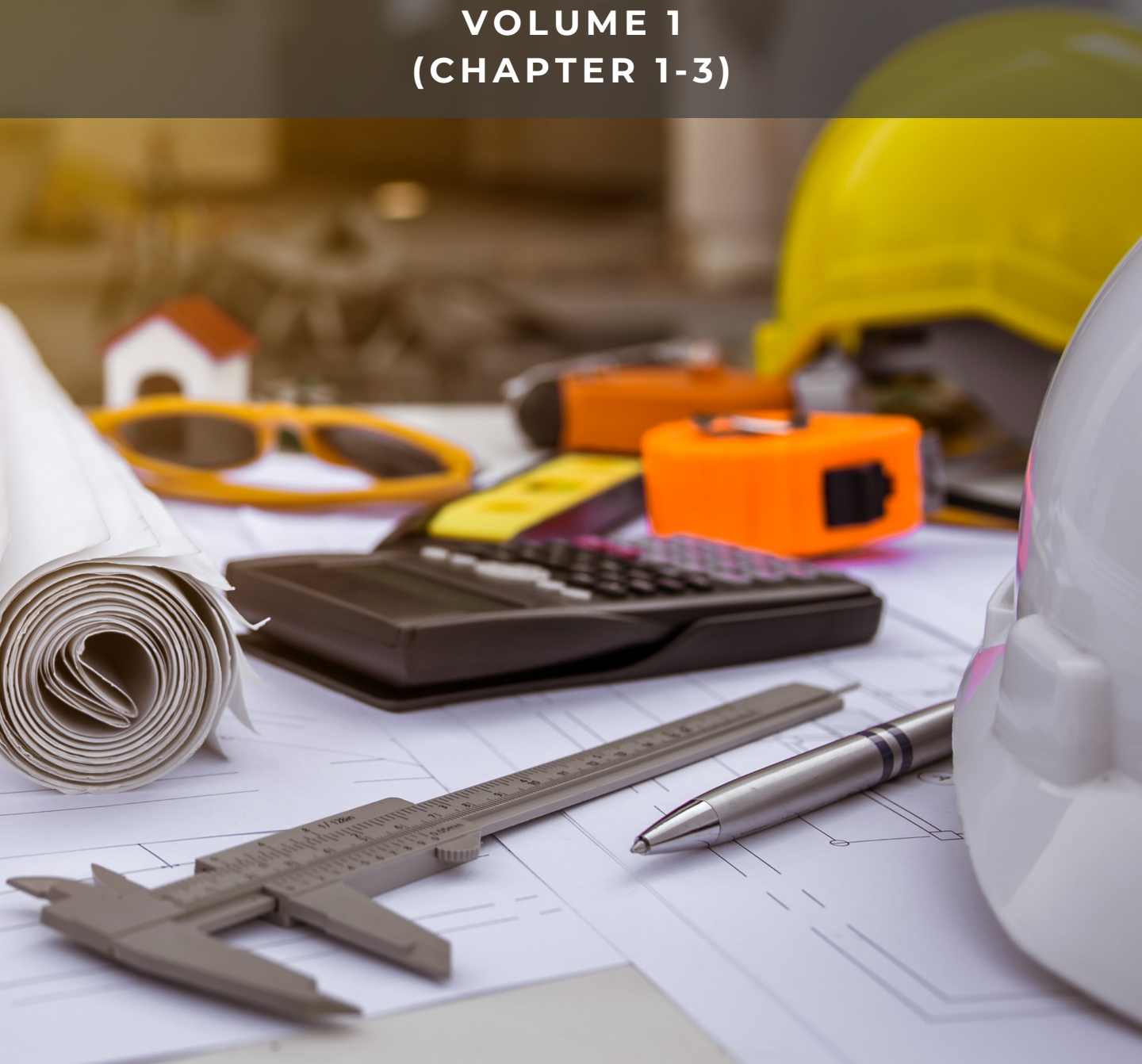

NOORAIN ITHNIN
FARA NUR ASMA MOHD BASRI
MOHD SAIFUL PAHRUDIN



ENGINEERING SCIENCE

Volume 1 (Chapter 1-3)

Noorain binti Ithnin
Fara Nur Asma binti Mohd Basri
Mohd Saiful bin Pahrudin

Perpustakaan Negara Malaysia Cataloguing –in–Publication Data

Noorain Ithnin, 1986- E
ENGINEERING SCIENCE. Volume 1 (Chapter 1-3) / Noorain Binti Ithnin,
Fara Nur Asma Binti Mohd Basri, Mohd Saiful Bin Pahrudin.

Mode of access: Internet

eISBN 978-967-2897-11-8

1. Physics.

2. Government publications--Malaysia.

3. Electronic books.

I. Fara Nur Asma Mohd. Basri, 1981-. II. Mohd. Saiful Pahrudin, 1981-.

III. Title.

530

Published By:
Politeknik Port Dickson
KM 14 Jalan Pantai, Si Rusa,
71050 Port Dickson
Negeri Sembilan.

August 2021

ACKNOWLEDGEMENT

PATRON

Mohamad Isa Bin Azhari
Director, Politeknik Port Dickson

ADVISORS

Dr. Nor Haniza Binti Mohamad
Deputy Director (Academic), Politeknik Port Dickson
Salmiah Binti Husain
Head of Mathematics, Science & Computer Department, Politeknik Port Dickson

EDITOR

Noorain Binti Ithnin
Head of Science Unit, Politeknik Port Dickson

FACILITATORS

Nin Hayati Binti Mohd Yusof
Fara Nur Asma Binti Mohd BAsri

WRITERS

Noorain Binti Ithnin
Fara Nur Asma Binti Mohd Basri
Mohd Saiful Bin Pahrudin

GRAPHIC DESIGNER

Noorain Binti Ithnin

We would like to convey our utmost gratitude to the Department of Polytechnic and Community College Education particularly the E-learning and Instructional Division (BIPD) for funding our e-book project.

We hereby declare that this module is our original work. To the best of our knowledge it contains no materials previously written or published by another person. However, if there is any, due acknowledgement and credit are mentioned accordingly in the e-book.

PREFACE

Engineering Science provides a comprehensive introduction to Physics. This e-book utilizes a user-friendly approach and is based on the latest syllabus. Fundamental physics concepts and principles are presented in point form, enabling students to quickly identify and understand each idea's essential points.

This e-book consists of three chapters which are physical quantities and measurement, linear motion, and force. It has been designed primarily as a guide for engineering students at the diploma level in Polytechnic. The solving problems in examples and practice questions are similar to past semester examination questions. This e-book hopes that students will gain a solid grasp of fundamental Physics knowledge and apply the knowledge to mastery physics concepts.

An appreciation represents by the author for any helpful criticism and suggestion to improve the quality of this e-book. Further comments and suggestions from an instructor using this e-book are most welcome.

TABLE OF CONTENTS

| | |
|------------------|-----|
| Acknowledgement | i |
| Preface | ii |
| Table of Content | iii |

CHAPTER 1 : Physical Quantities & Measurement

| | |
|-------------------------------------|----|
| Learning Outcomes | 1 |
| Physical Quantity | 2 |
| Base Quantity | 3 |
| Derived Quantity | 4 |
| International System (SI) of Units | 5 |
| Scalar & Vector Quantities | 6 |
| Unit Conversion | 7 |
| Conversion of Metric Unit | 8 |
| Conversion of Customary Unit | 10 |
| Measurement | 14 |
| Consistency, Accuracy & Sensitivity | 15 |
| Errors in measurement | 17 |
| Vernier Caliper | 18 |
| Micrometer Screw Gauge | 25 |

CHAPTER 2 : Linear Motion

| | |
|-------------------------------------|----|
| Learning Outcomes | 33 |
| Linear and Non-Linear Motion | 34 |
| Distance and Displacement | 35 |
| Speed and Velocity | 38 |
| Average Velocity | 39 |
| Acceleration and Deceleration | 41 |
| Kinematic Formula | 45 |
| Velocity – Time Graph | 52 |
| Experiment Related To Linear Motion | 55 |
| Exercise | 57 |

CHAPTER 3 : Force

| | |
|--------------------------------|----|
| Learning Outcomes | 58 |
| Concept of Force | 59 |
| Type of Forces | 60 |
| Effect of Net Force | 61 |
| Newton's Law | 62 |
| Weight and Mass | 66 |
| Forces in Equilibrium | 67 |
| Resultant Force | 70 |
| Concept of Moment of Force | 78 |
| Principle of Moment of Force | 83 |
| Moment of Force (Force Moment) | 84 |
| Resultant Moment of Force | 85 |

| | |
|-----------|----|
| Reference | 94 |
|-----------|----|

CHAPTER 1



PHYSICAL QUANTITIES & MEASUREMENT

Learning Outcomes:

At the end of this chapter, you should be able to

- Understand the physical quantities
- Solve Problems of Unit Conversion
- Describe errors in measurement
- Apply the technique of measurement using Vernier Caliper and Micrometer Screw Gauge

1.1 Physical Quantity

□ There are two types of quantity:

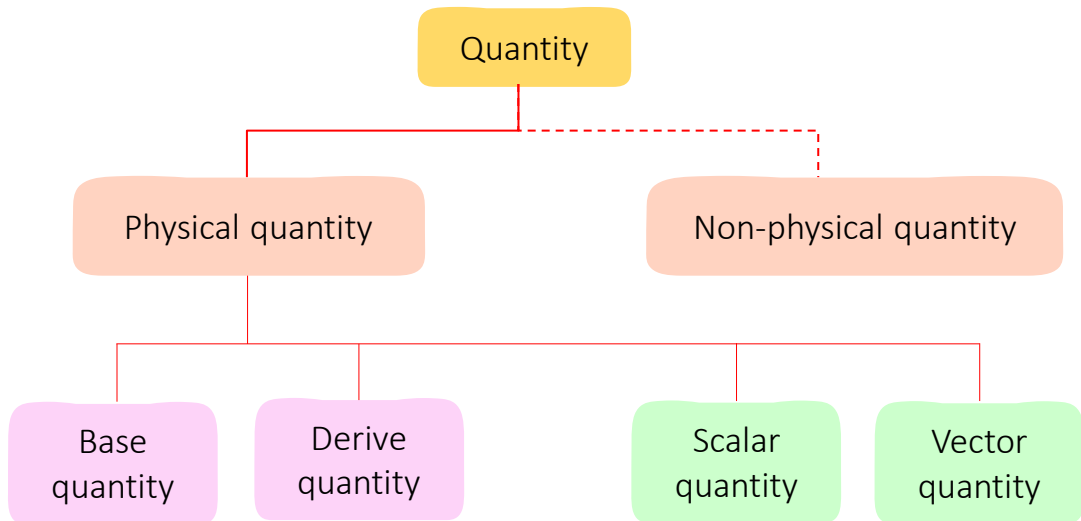

□ **Physical quantity**

- Physical quantity is a quantity that can be measured.
- Example: speed, length, mass etc.

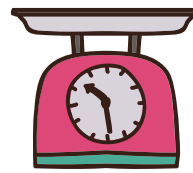

Weight



Time

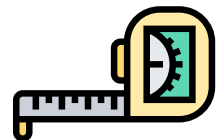

Length

□ **Non-physical quantity**

- A quantity that cannot be measured
- Example: Beauty, feelings etc.



Feelings

Base Quantity

- Base quantity is a physical quantity which cannot be defined in terms of other physical quantity.

Table 1: Base quantity, symbols & SI Unit

| Base Quantity | Symbol | SI Unit | Symbol of Unit |
|---------------------|--------|----------|----------------|
| Length | l | meter | m |
| Mass | m | kilogram | kg |
| Time | t | second | s |
| Temperature | T | kelvin | K |
| Current | I | ampere | A |
| Luminous Intensity | I_v | candela | cd |
| Amount of substance | N_A | mole | $mole$ |



Try this!

Choose the base quantity measured by multimeter?

- A Resistance
- B Current
- C Voltage
- D Luminous Intensity

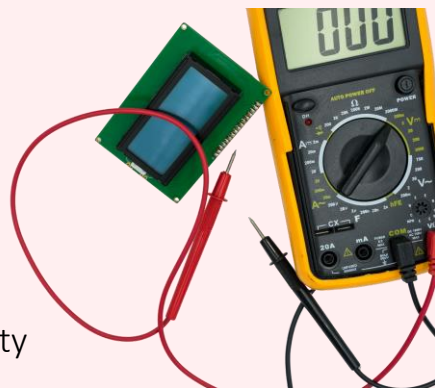

Derived Quantity

- Derived quantity is a physical quantity that can be derived from a combination of more than two base quantities.

Table 2: Derived quantity & SI unit

| Derived Quantity | Symbol | SI Unit | Symbol of Unit |
|------------------|--------|--------------------------|------------------|
| Area | A | square meter | m^2 |
| Volume | V | cubic meter | m^3 |
| Density | ρ | kilogram per cubic meter | $\frac{kg}{m^3}$ |
| Velocity | v | meter per second | $\frac{m}{s}$ |
| Acceleration | a | meter per second squared | $\frac{m}{s^2}$ |
| Force | F | Newton | N |
| Work | W | Joule | J |
| Pressure | P | Watt | W |

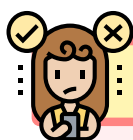

Try this!

Which of the following physical quantities is derived quantity?

- A Electric current C Time
- B Mass D Momentum

International System (SI) of units

- ❑ International System (SI) unit is the international standard for measurement.
- ❑ A specific SI unit represents each physical quantity.
- ❑ The SI unit is made up of special names and symbols.
- ❑ Metric prefixes are used to represent very large or very small multiple numbers of physical quantities magnitude.

Table 3: Prefixes

| Name | Symbol | Multiplication Factor | Example | Symbol for example |
|-------|--------|-----------------------|-------------|--------------------|
| tera | T | 10^{12} | terabyte | TB |
| giga | G | 10^9 | gigahertz | GHz |
| mega | M | 10^6 | meganewton | MN |
| kilo | k | 10^3 | kilojoule | kJ |
| centi | c | 10^{-2} | centimeter | cm |
| milli | m | 10^{-3} | milliliter | ml |
| micro | μ | 10^{-6} | microsecond | μ s |
| nano | n | 10^{-9} | nanowatt | nW |
| pico | p | 10^{-12} | picogram | pg |

Scalar & Vector Quantities

❑ **Scalar quantity**

- Scalar quantity is a quantity that has magnitude only

❑ **Vector quantity**

- Vector quantity is a quantity that has magnitude and direction

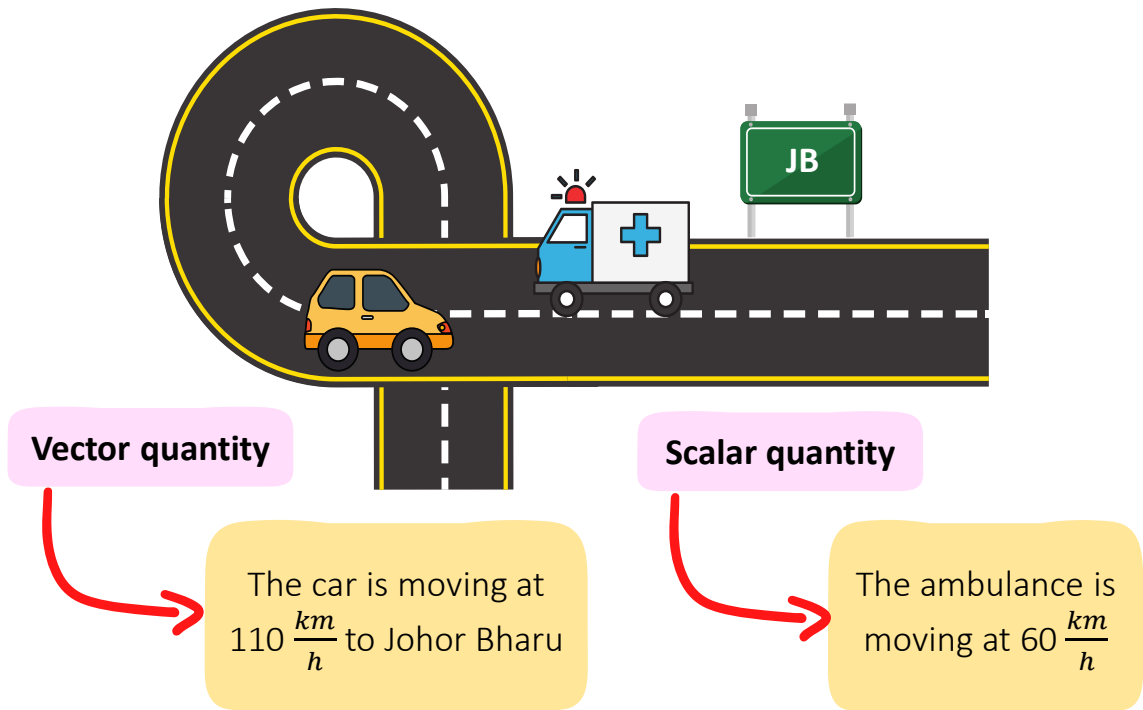

Table 4: Scalar and vector quantity

| Scalar Quantity | Unit | Vector Quantity | Unit |
|-----------------|---------------|-----------------|---------------|
| Speed | $\frac{m}{s}$ | Velocity | $\frac{m}{s}$ |
| Distance | m | Displacement | m |
| Mass | kg | Weight | N |

1.2 Unit Conversion

- In certain situations, the values of physical quantities need to be changed from one unit to another. The easiest way to do a conversion is by unit cancellation.



Example 1

Convert $175 \frac{km}{h^2}$ to $\frac{m}{s^2}$

Step 1

Write each conversion factor as a fraction with comparable units (example: km,m,cm for length)

$$175 \frac{km}{h^2} \times \frac{m}{km} \times \frac{h^2}{s^2}$$

Step 2

Place the 1 by the larger unit/unit with prefixes
Place the multiplication factor on the opposite side

$$175 \frac{km}{h^2} \times \frac{10^3 m}{1 km} \times \frac{1 h^2}{(3600)^2 s^2}$$

Step 3

Cancel out units that appear on top and bottom

$$175 \frac{\cancel{km}}{\cancel{h^2}} \times \frac{10^3 m}{1 \cancel{km}} \times \frac{1 \cancel{h^2}}{(3600)^2 s^2}$$

Step 4

Solve the multiplication problem

$$= \frac{175 \times 10^3}{3600^2} = 0.0135 \frac{m}{s^2}$$



For videos on conversion of unit, click this link!

<https://bit.ly/2VPejON>

Conversion of Metric Unit

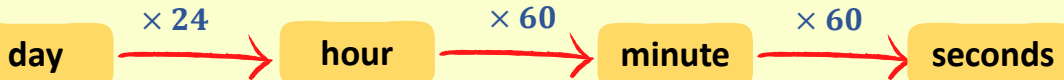

Example 2

Convert 26.5 cm^2 to m^2

Solution:

$$\begin{aligned} 26.5 \text{ cm}^2 &\times \frac{(10^{-2})^2 \text{ m}^2}{1 \text{ cm}^2} \\ &= 26.5 \times (10^{-2})^2 \\ &= 2.65 \times 10^{-4} \text{ m}^2 \end{aligned}$$

Example 3

Convert $85.5 \frac{\text{km}}{\text{h}}$ to $\frac{\text{m}}{\text{s}}$

Solution:

$$\begin{aligned} 85.5 \frac{\text{km}}{\text{h}} &\times \frac{10^3 \text{ m}}{1 \text{ km}} \times \frac{1 \text{ h}}{3600 \text{ s}} \\ &= \frac{85.5 \times 10^3}{3600} \\ &= 23.75 \frac{\text{m}}{\text{s}} \end{aligned}$$

Example 4

Convert 78 kN to μN

Solution:

$$\begin{aligned} 78 \text{ kN} &\times \frac{10^3 \text{ N}}{1 \text{ kN}} \times \frac{1 \mu\text{N}}{(10^{-6}) \text{ N}} \\ &= \frac{78 \times 10^3}{10^{-6}} \\ &= 7.8 \times 10^{10} \mu\text{N} \end{aligned}$$

Example 5

Convert $7 \frac{\text{g}}{\text{cm}^3}$ to $\frac{\text{kg}}{\text{m}^3}$

Solution:

$$\begin{aligned} 7 \frac{\text{g}}{\text{cm}^3} &\times \frac{1 \text{ kg}}{10^3 \text{ g}} \times \frac{1 \text{ cm}^3}{(10^{-2})^3 \text{ m}^3} \\ &= \frac{7}{10^3 \times (10^{-2})^3} \\ &= 7000 \frac{\text{kg}}{\text{m}^3} \end{aligned}$$



Practice Question 1

Convert the following metric unit

a) 13 GW to MW

Answer: $1.3 \times 10^4 \text{ MW}$

b) $471 \frac{\text{kg}}{\text{m}^3} \text{ to } \frac{\text{g}}{\text{cm}^3}$

Answer: $0.471 \frac{\text{g}}{\text{cm}^3}$

c) $165 \frac{\text{km}}{\text{h}^2} \text{ to } \frac{\text{m}}{\text{s}^2}$

Answer: $0.0127 \frac{\text{m}}{\text{s}^2}$

d) $9786 \frac{\mu\text{m}}{\text{min}} \text{ to } \frac{\text{m}}{\text{s}}$

Answer: $1.631 \times 10^{-4} \frac{\text{m}}{\text{s}}$

e) $7.8 \frac{\text{g}}{\text{mm}^3} \text{ to } \frac{\text{kg}}{\text{m}^3}$

Answer: $7.8 \times 10^6 \frac{\text{kg}}{\text{m}^3}$

f) $19.62 \frac{\text{kN}}{\text{cm}^2} \text{ to } \frac{\text{N}}{\text{m}^2}$

Answer: $1.962 \times 10^8 \frac{\text{N}}{\text{m}^2}$

g) $0.8 \text{ kHz to } \mu\text{Hz}$

Answer: $8.0 \times 10^8 \mu\text{Hz}$

h) $17.98 \text{ cm}^2 \text{ to } \text{m}^2$

Answer: $1.798 \times 10^{-3} \text{ m}^2$

i) 2 TB to MB

Answer: $2 \times 10^6 \text{ MB}$

j) 40.5 days to min

Answer: $5.832 \times 10^4 \text{ min}$

k) $178 \frac{\text{km}}{\text{h}} \text{ to } \frac{\text{m}}{\text{s}}$

Answer: $49.44 \frac{\text{m}}{\text{s}}$



For more exercise on conversion of metric unit, scan this QR code!

Conversion of Customary Unit

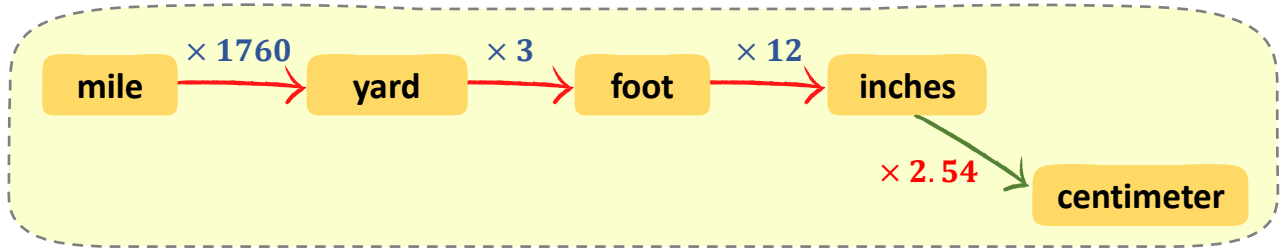

Example 1

Convert 4.8 feet to inches

Solution:

$$\begin{aligned} 4.8 \text{ feet} &\times \frac{12 \text{ inches}}{1 \text{ foot}} \\ &= 4.8 \times 12 \\ &= 57.6 \text{ inches} \end{aligned}$$



Example 2

Convert 1.8 feet to yards

Solution:

$$\begin{aligned} 1.8 \text{ feet} &\times \frac{1 \text{ yard}}{3 \text{ feet}} \\ &= \frac{1.8}{3} \\ &= 0.6 \text{ yards} \end{aligned}$$



Example 3

3.8 miles to feet

Solution:

$$\begin{aligned} 3.8 \text{ miles} &\times \frac{1760 \text{ yards}}{1 \text{ mile}} \times \frac{3 \text{ feet}}{1 \text{ yards}} \\ &= 3.8 \times 1760 \times 3 \\ &= 20064 \text{ feet} \end{aligned}$$



Example 4

Convert 1.7 yards to inches

Solution:

$$\begin{aligned} 1.7 \text{ yards} &\times \frac{3 \text{ feet}}{1 \text{ yard}} \times \frac{12 \text{ inches}}{1 \text{ foot}} \\ &= 1.7 \times 3 \times 12 \\ &= 61.2 \text{ inches} \end{aligned}$$

Conversion of Customary Unit

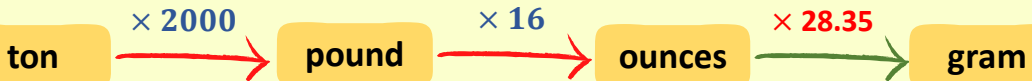

Example 1

Convert 78 *pounds* to *ounces*

Solution:

$$\begin{aligned} 78 \text{ pounds} &\times \frac{16 \text{ ounces}}{1 \text{ pounds}} \\ &= 78 \times 16 \\ &= 1248 \text{ ounces} \end{aligned}$$

Example 2

Convert 270 *ounces* to *pounds*

Solution:

$$\begin{aligned} 270 \text{ ounces} &\times \frac{1 \text{ pounds}}{16 \text{ ounces}} \\ &= \frac{270}{16} \\ &= 16.875 \text{ pounds} \end{aligned}$$

Example 3

Convert 6.5 *ounces* to *grams*

Solution:

$$\begin{aligned} 6.5 \text{ oz} &\times \frac{28.35 \text{ g}}{1 \text{ oz}} \\ &= 6.5 \times 28.35 \\ &= 184.275 \text{ g} \end{aligned}$$

Example 4

Convert 46.3 *pounds* to *grams*

Solution:

$$\begin{aligned} 46.3 \text{ lb} &\times \frac{16 \text{ oz}}{1 \text{ lb}} \times \frac{28.35 \text{ g}}{1 \text{ oz}} \\ &= 46.3 \times 16 \times 28.35 \\ &= 21001.68 \text{ g} \end{aligned}$$

Conversion of Customary Unit

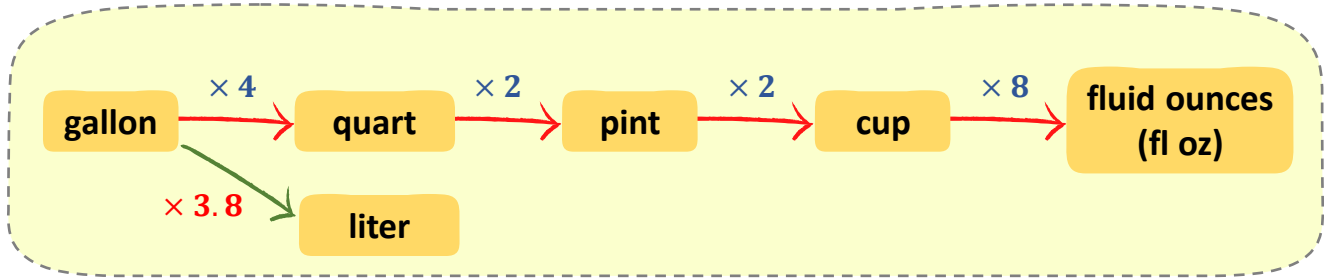

Example 1

Convert 6.9 cups to fl oz

Solution:

$$\begin{aligned} 6.9 \text{ cups} &\times \frac{8 \text{ fl oz}}{1 \text{ cup}} \\ &= 6.9 \times 8 \\ &= 55.2 \text{ fl oz} \end{aligned}$$



Example 2

Convert 67 fl oz to pints

Solution:

$$\begin{aligned} 67 \text{ fl oz} &\times \frac{1 \text{ cup}}{8 \text{ fl oz}} \times \frac{1 \text{ pints}}{2 \text{ cups}} \\ &= \frac{67}{8 \times 2} \\ &= 4.188 \text{ pints} \end{aligned}$$



Example 3

Convert 1.8 quarts to cup

Solution:

$$\begin{aligned} 1.8 \text{ quarts} &\times \frac{2 \text{ pints}}{1 \text{ quart}} \times \frac{2 \text{ cup}}{1 \text{ pints}} \\ &= 1.8 \times 2 \times 2 \\ &= 7.2 \text{ cups} \end{aligned}$$



Example 4

Convert 40.8 pints to gallons

Solution:

$$\begin{aligned} 40.8 \text{ pints} &\times \frac{1 \text{ quarts}}{2 \text{ pints}} \times \frac{1 \text{ gallons}}{4 \text{ quarts}} \\ &= \frac{40.8}{2 \times 4} \\ &= 5.1 \text{ gallons} \end{aligned}$$



Practice Question 2

Convert the following customary unit

- a) 480 inches to yard Answer: 13.33 yards
-
- b) 745 inches² to feet² Answer: 5.174 feet²
-
- c) 91.6 pounds to ounces Answer: 1465.6 ounces
-
- d) 3.4 gallons to cups Answer: 54.4 cups
-
- e) 65.1 $\frac{\text{miles}}{\text{h}}$ to $\frac{\text{km}}{\text{h}}$ Answer: 104.768 $\frac{\text{km}}{\text{h}}$
-
- f) 80.5 feet² to m² Answer: 602.035 m²
-
- g) 0.8 pounds to kilogram Answer: 0.363 kg
-
- h) 21.6 gallons to liters Answer: 81.765 ℓ
-
- i) 29025 feet to km Answer: 8.847 km
-
- j) 4.54 yards to meter Answer: 4.151 m
-
- k) 85.6 ft³ to m³ Answer: 17.76 × 10³m³
-

1.3 Measurement

- ❑ Measurement is the process of determining the **size** or **magnitude** of a physical quantity of an object.
- ❑ Before a measuring instrument exists, people use the palm, forearm and feet to measure the length. However, these methods gave inaccurate results.
- ❑ Nowadays, people use a ruler and measuring tape to measure a length.



- ❑ In engineering, we perform practical lab work and experiments where readings are taken using suitable measuring instruments.
- ❑ For example, in locksmithing or metalworking, the vernier caliper and micrometer screw gauge are more suitable for making accurate and precise cuts over metallic surfaces. Both measuring instruments help to measure the thickness and diameter with high accuracy and precision.

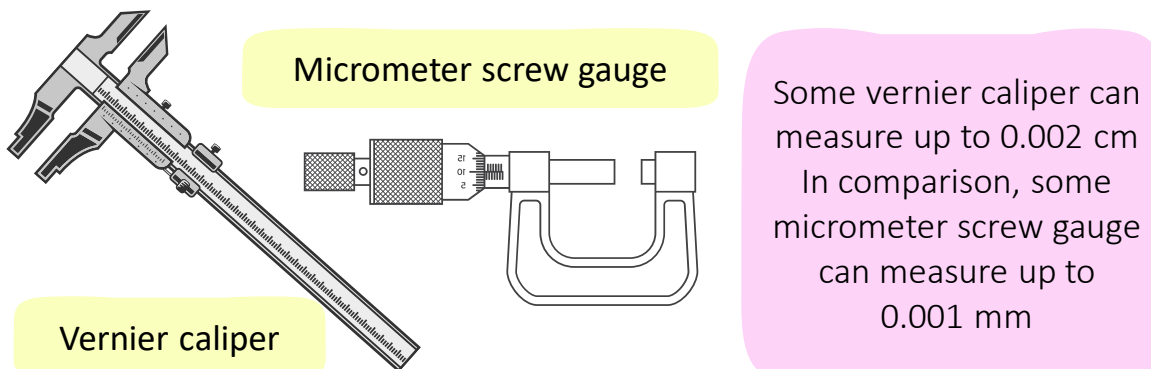

Consistency, Accuracy & Sensitivity

- When making a measurement, we must be aware of the consistency and accuracy of the measurement.
- In order to ensure consistency and accuracy, the measuring instrument used must have appropriate sensitivity.

Consistency

The ability of the instrument to give consistent readings when the same physical quantity is measured more than once

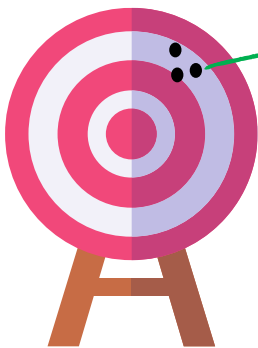

Consistent

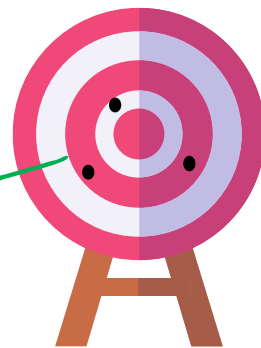

Inconsistent

The consistency of measurement can be improved by:

- ✓ Taking a reading with caution
- ✓ Avoid parallax error
- ✓ Make sure the measuring instrument used is not defective



Accuracy

The ability of an instrument to give measurement of a physical quantity which are close to the actual value

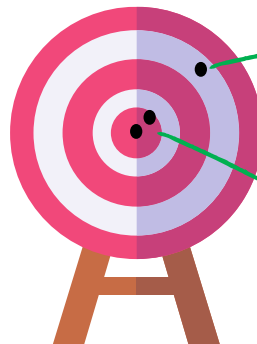

Inaccurate

Accurate



The accuracy of measurement can be improved by:

- ✓ Using a measuring instrument that is more sensitive
- ✓ Avoid parallax error
- ✓ Avoid zero error
- ✓ Repeating measurement

Sensitivity

The ability of the instrument to detect small changes in a quantity measured

- The smaller the minimum scale division, the more sensitive the measuring instrument is.

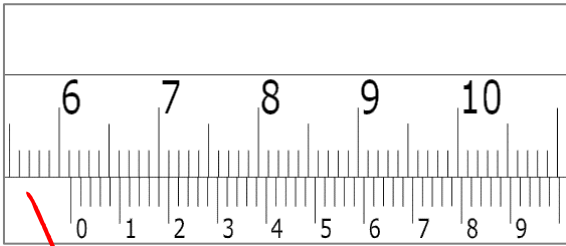

The least count of this vernier caliper is 0.002 cm

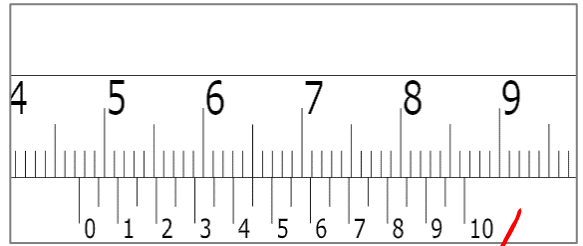

The least count of this vernier caliper is 0.005 cm

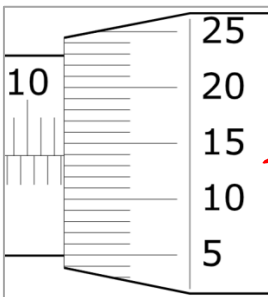

The least count of this micrometer screw gauge is 0.01 mm



Least count is the smallest value that can be measured by the measuring instrument

Errors in Measurement

- ❑ Measurement is done by bringing the target object into contact with the measuring instrument to read its physical quantity.
- ❑ However, errors may occur in the process of measuring the object. An error is a difference between the actual value and the value obtained from the measurement.
- ❑ There are two types of error: random error and systematic error
- ❑ A random error will affect the precision of measurement. While systematic error can influence a measurement's accuracy.

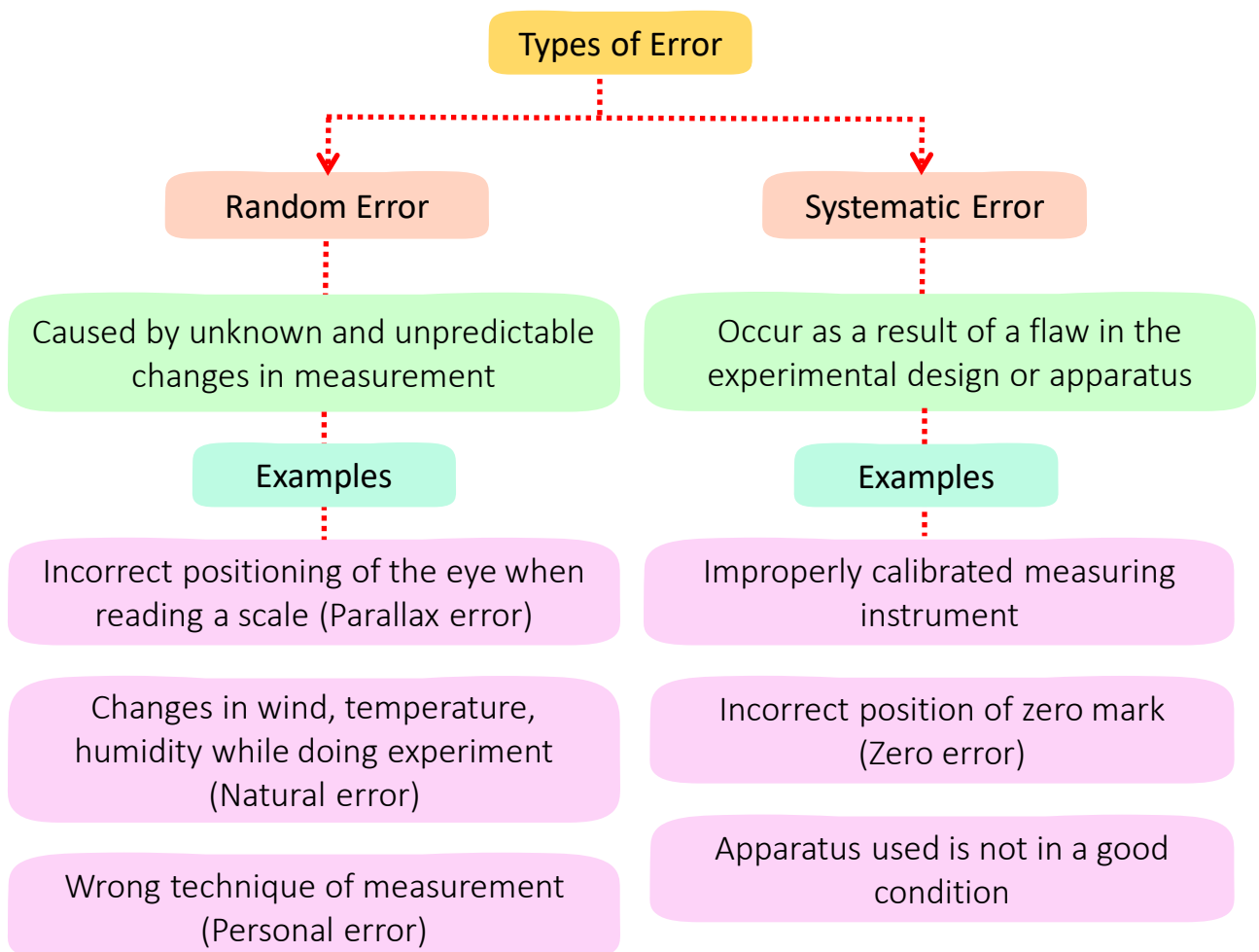

1.4 Vernier Caliper

- ❑ Vernier caliper is a measuring tool used for measuring linear dimensions. It is used to measure the thickness, diameter and depth of an object.
- ❑ It is mainly used in mechanical engineering, education, aerospace, automobile, metalworking, woodworking and medical.
- ❑ The structure of the vernier caliper is shown below:

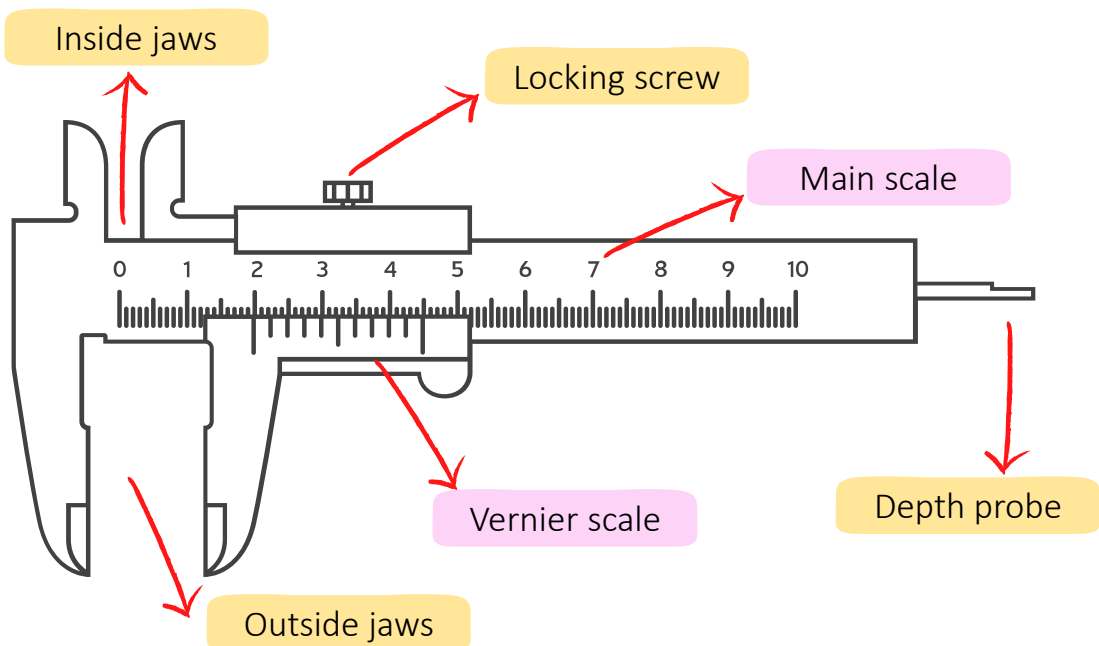

| Structure | Function |
|---------------|---|
| Inside jaws | For measuring inner dimension of object |
| Outside jaws | For measuring outer dimension of object |
| Depth Probe | For measuring depth inside of object |
| Locking screw | To lock the vernier arm from moving |
| Main scale | For main scale reading |
| Vernier scale | For secondary scale reading |

How to read the vernier caliper?

- Figure below shows the reading of the vernier caliper. The main scale is marked in divisions of 0.1 cm, while the vernier scale is obtained using the formula of least count depending on the number of divisions on the vernier scale.

Question

The following vernier caliper has no zero error. Determine the reading on the caliper.

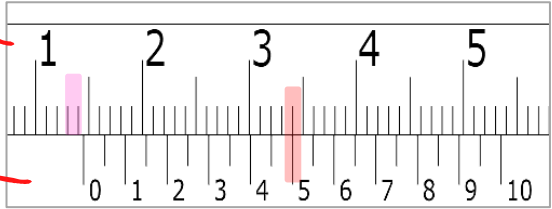

Main scale
Smallest division is 0.1 cm

Vernier scale
Total division is 20

Step 1 Find the least count

Least count is the smallest value that can be measured by the measuring instrument

$$\begin{aligned} \text{Least count} &= \frac{\text{smallest division on main scale}}{\text{number of division on vernier scale}} \\ &= \frac{0.1}{20} \\ &= 0.005 \text{ cm} \end{aligned}$$

Step 2

Read the main scale marking just before the zero marking on the vernier scale

$$\text{Main scale} = 1.4 \text{ cm}$$

How to read the vernier caliper?

Step 3

Find the vernier scale marking which joins the main scale marking

$$\text{Vernier scale} = 10 \times 0.005 \text{ cm} = 0.05 \text{ cm}$$

Step 4

Find the obtained reading

$$\begin{aligned} \text{Obtained reading} &= \text{Main scale} + \text{Vernier scale} \\ &= 1.4 + 0.05 \\ &= 1.45 \text{ cm} \end{aligned}$$

Additional Question

If the vernier caliper has $+0.002 \text{ cm}$ of zero error. Determine the reading on the caliper.

Step 5

Find the actual reading

$$\begin{aligned} \text{Actual reading} &= \text{Obtained reading} - \text{zero error} \\ &= 1.45 - (+0.002) \\ &= 1.448 \text{ cm} \end{aligned}$$



Obtained reading = Main scale + Vernier scale

Actual reading = Obtained reading – zero error

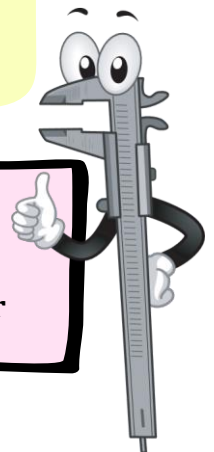

Zero Error of Vernier Caliper

- Before finding the actual reading of the measurement, we need to check for zero error. **Zero error** is an error that occurred due to wear and tear or manufacturing defects of the instrument.
- Zero error is obtained when the jaws are closed firmly. If the main scale zero and vernier scale zero marks form a straight line, then there is no zero error.

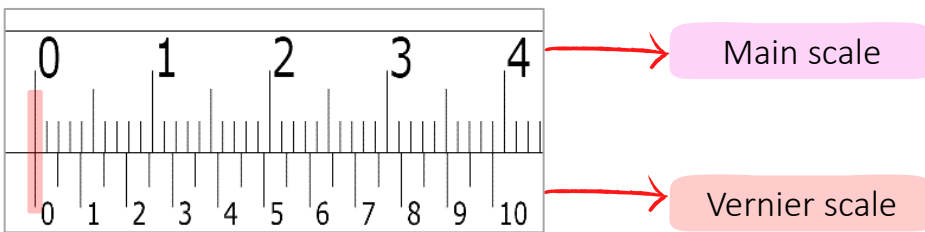

- Positive zero error** occurs if the vernier scale zero position is to the right of main scale zero markings.

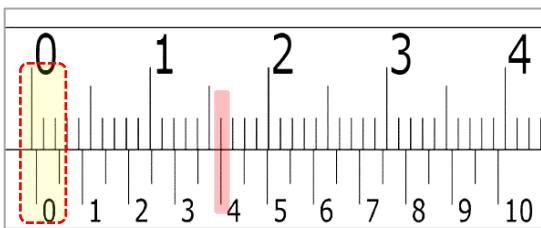

Find the vernier scale marking which joins the main scale marking

$$\begin{aligned}\text{Zero error} &= 8 \times 0.005 \text{ cm} \\ &= +0.04 \text{ cm}\end{aligned}$$

- Negative zero error** occurs if the vernier scale zero position is to the left of main scale zero markings.

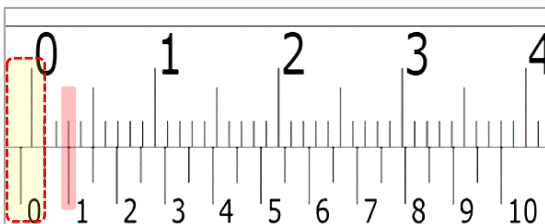

Find the vernier scale marking which joins the main scale marking

$$\begin{aligned}\text{Zero error} &= -[0.1 - (2 \times 0.005)] \text{ cm} \\ &= -0.09 \text{ cm}\end{aligned}$$

Vernier Caliper



Example 1

The following vernier caliper has no zero error.
Determine the obtained reading on the caliper.

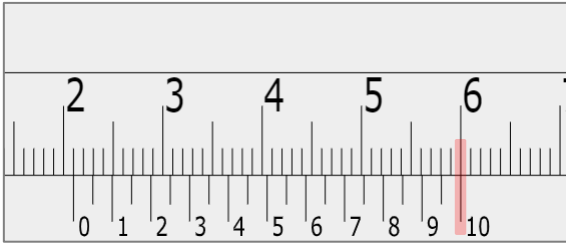

Solution:

$$\text{Least count} = \frac{0.1}{20} = 0.005 \text{ cm}$$

$$\text{Main scale} = 2.0 \text{ cm}$$

$$\text{Vernier scale} = 20 \times 0.005 = 0.1 \text{ cm}$$

$$\text{Obtained reading} = 2.0 + 0.1 = 2.1 \text{ cm}$$



Example 2

The following vernier caliper has no zero error.
Determine the obtained reading on the caliper.

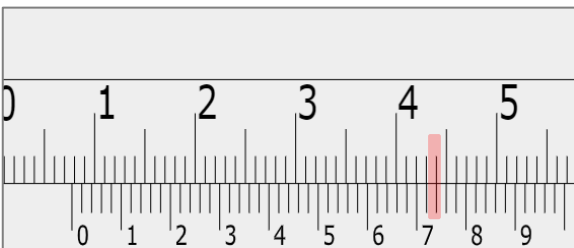

Solution:

$$\text{Least count} = \frac{0.1}{50} = 0.002 \text{ cm}$$

$$\text{Main scale} = 0.7 \text{ cm}$$

$$\text{Vernier scale} = 37 \times 0.002 = 0.074 \text{ cm}$$

$$\text{Obtained reading} = 0.7 + 0.074 = 0.774 \text{ cm}$$

Vernier Caliper



Example 3

The following vernier caliper has $+0.003 \text{ cm}$ of zero error. Determine the reading on the caliper.

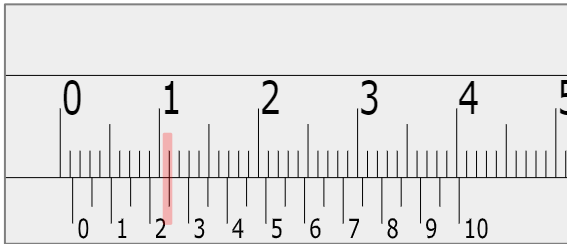

Solution:

$$\text{Least count} = \frac{0.1}{20} = 0.005 \text{ cm}$$

$$\text{Main scale} = 0.1 \text{ cm}$$

$$\text{Vernier scale} = 5 \times 0.005 = 0.025 \text{ cm}$$

$$\text{Obtained reading} = 0.1 + 0.025 = 0.125 \text{ cm}$$

$$\text{True reading} = 0.125 - (+0.003) = 0.122 \text{ cm}$$



Example 4

The following vernier caliper has -0.009 cm of zero error. Determine the reading on the caliper.

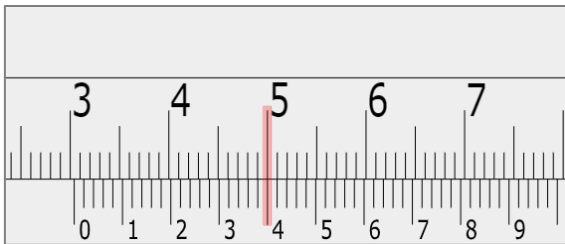

Solution:

$$\text{Least count} = \frac{0.1}{50} = 0.002 \text{ cm}$$

$$\text{Main scale} = 3.0 \text{ cm}$$

$$\text{Vernier scale} = 20 \times 0.002 = 0.04 \text{ cm}$$

$$\text{Obtained reading} = 3.0 + 0.04 = 3.04 \text{ cm}$$

$$\text{True reading} = 3.04 - (-0.009) = 3.049 \text{ cm}$$



Practice Question 3

Determine the reading on the caliper:

a)

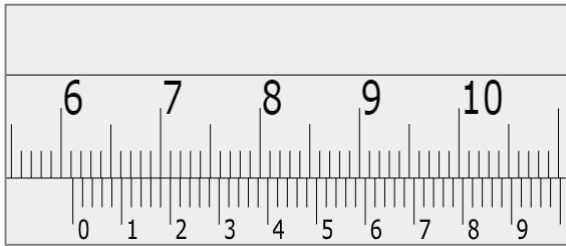

Answer: 6.118 cm

b)

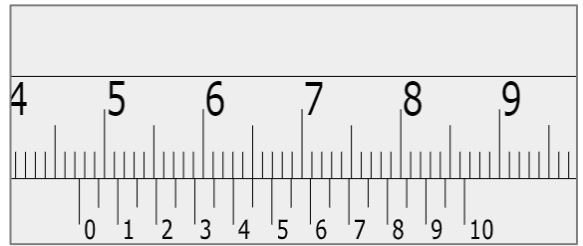

Answer: 4.745 cm

c)

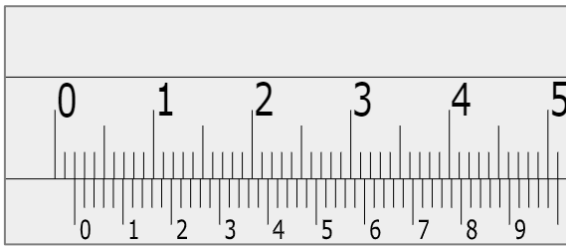

Answer: 0.20 cm

d)

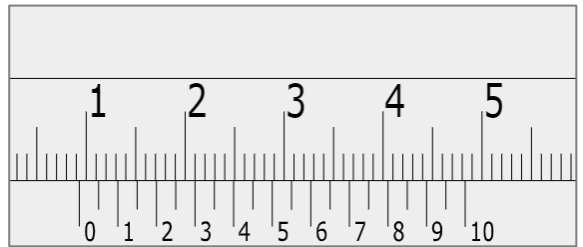

Answer: 0.93 cm

e)

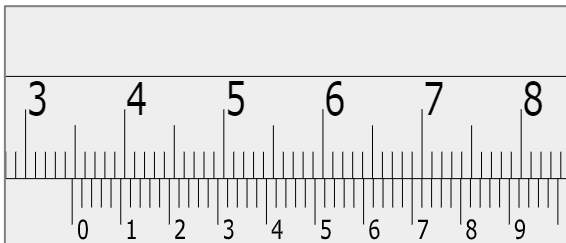

Answer: 3.47 cm

f)

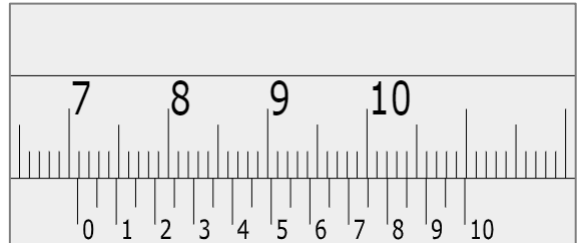

Answer: 7.085 cm



For more exercise on vernier caliper, scan this QR code!

1.5 Micrometer Screw Gauge

- ❑ A micrometer screw gauge is a measuring instrument that features a calibrated screw that is primarily used to measure small dimensions of thickness smaller than those measured by a vernier caliper.
- ❑ The gauge application is widely used in almost all fields of science, such as in engineering, manufacturing, and different scientific experiments.
- ❑ The structure of the micrometer screw gauge is shown below:

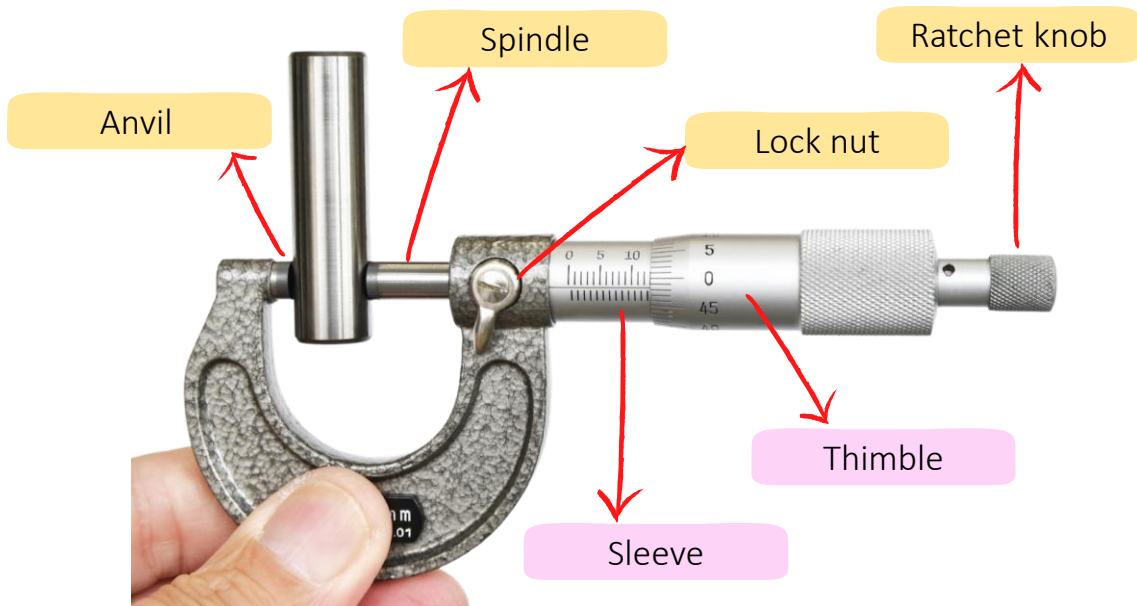

| Structure | Function |
|-----------------|---|
| Anvil & Spindle | Held the object in between |
| Lock nut | To lock and hold the scales at a particular position |
| Ratchet knob | Limit the gauge by preventing spindle from moving further |
| Sleeve | For main scale reading |
| Thimble | For secondary scale reading |

How to read the Micrometer Screw Gauge?

- Figure below shows the reading of the micrometer screw gauge. The main scale is marked in divisions of 0.5 mm, while the circular scale is obtained using the formula of least count depending on the number of divisions on the circular scale.

Question

The following micrometer screw gauge has no zero error. Determine the reading on the gauge.

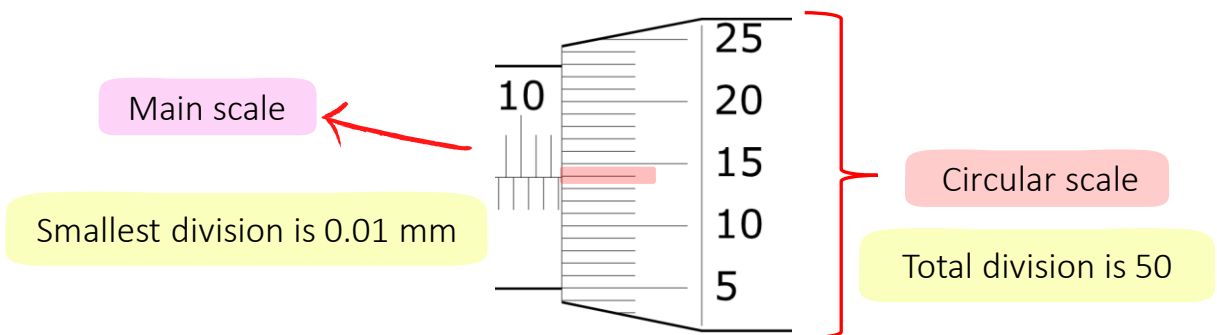

Step 1

Find the least count

$$\begin{aligned} \text{Least count} &= \frac{\text{smallest division on main scale}}{\text{number of division on circular scale}} \\ &= \frac{0.5}{50} \\ &= 0.01 \text{ mm} \end{aligned}$$

Step 2

Read the main scale marking just before the zero marking on the circular scale

Main scale = 10.5 mm

How to read the Micrometer Screw Gauge?

Step 3

Find the circular scale marking which joins the main scale marking

$$\text{Circular scale} = 14 \times 0.01 \text{ mm} = 0.14 \text{ mm}$$

Step 4

Find the obtained reading

$$\begin{aligned} \text{Obtained reading} &= \text{Main scale} + \text{Circular scale} \\ &= 10.5 + 0.14 \\ &= 10.64 \text{ mm} \end{aligned}$$

Additional Question

If the micrometer screw gauge has -0.06 mm of zero error. Determine the reading on the gauge.

Step 5

Find the actual reading

$$\begin{aligned} \text{Actual reading} &= \text{Obtained reading} - \text{zero error} \\ &= 10.64 - (-0.06) \\ &= 10.70 \text{ mm} \end{aligned}$$



Obtained reading = Main scale + Circular scale

Actual reading = Obtained reading – zero error

Zero Error of Micrometer Screw Gauge

- ❑ **Zero error** is obtained when the gauge is fully closed. If the main scale zero markings and circular scale zero marking form a straight line, there is no zero error as shown in figure below.

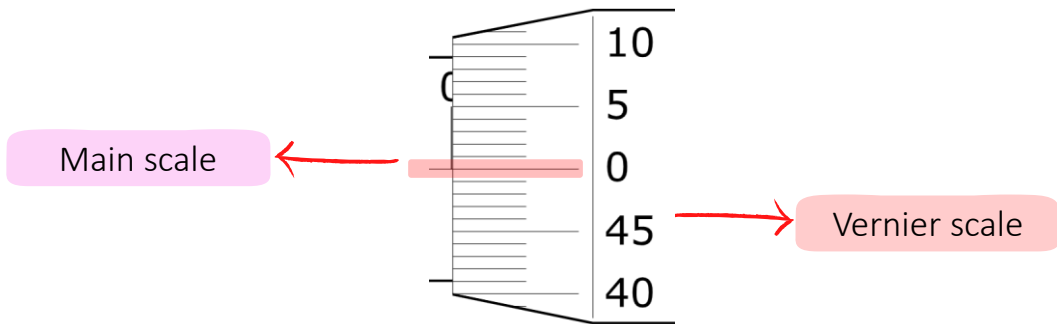

- ❑ **Positive zero error** occurs if the circular scale zero position is below the main scale zero markings.

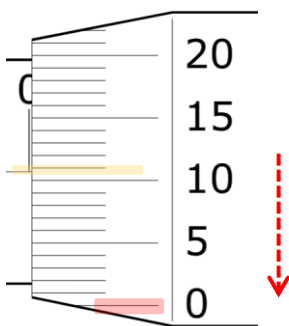

Find the circular scale marking which joins the main scale marking

$$\begin{aligned}\text{Zero error} &= 10 \times 0.01 \text{ mm} \\ &= +0.10 \text{ mm}\end{aligned}$$

- ❑ **Negative zero error** occurs if the circular scale zero position is above the main scale zero marking.

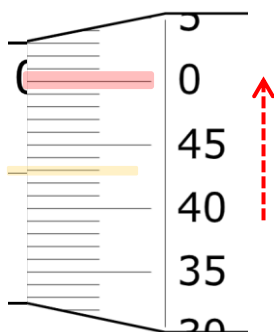

Find the circular scale marking which joins the main scale marking

$$\begin{aligned}\text{Zero error} &= 7 \times 0.01 \text{ mm} \\ &= -0.07 \text{ mm}\end{aligned}$$

Micrometer Screw Gauge



Example 1

The following micrometer screw gauge has no zero error. Determine the obtained reading on the gauge.

Solution:

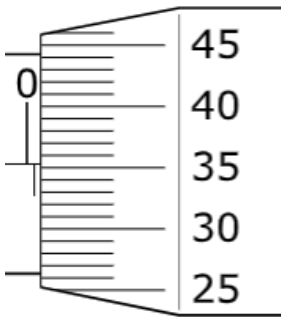

$$\text{Least count} = \frac{0.5}{50} = 0.01 \text{ mm}$$

$$\text{Main scale} = 0.5 \text{ mm}$$

$$\text{Circular scale} = 35 \times 0.01 = 0.35 \text{ mm}$$

$$\text{Obtained reading} = 0.5 + 0.35 = 0.85 \text{ mm}$$



Example 2

The following micrometer screw gauge has no zero error. Determine the obtained reading on the gauge.

Solution:

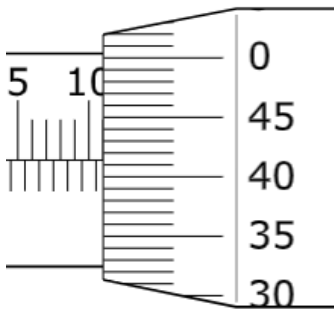

$$\text{Least count} = \frac{0.5}{50} = 0.01 \text{ mm}$$

$$\text{Main scale} = 10.5 \text{ mm}$$

$$\text{Circular scale} = 41 \times 0.01 = 0.41 \text{ mm}$$

$$\text{Obtained reading} = 10.5 + 0.41 = 10.91 \text{ mm}$$

Micrometer Screw Gauge



Example 3

The following micrometer screw gauge has $+0.01 \text{ mm}$ of zero error. Determine the reading on the gauge.

Solution:

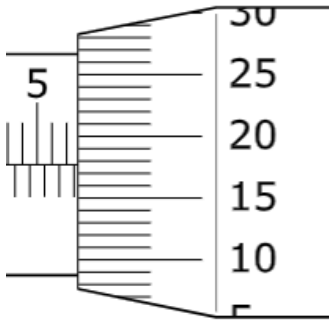

$$\text{Least count} = \frac{0.5}{50} = 0.01 \text{ mm}$$

$$\text{Main scale} = 7.5 \text{ mm}$$

$$\text{Circular scale} = 17 \times 0.01 = 0.17 \text{ mm}$$

$$\text{Obtained reading} = 7.5 + 0.17 = 7.67 \text{ mm}$$

$$\text{True reading} = 7.67 - (+0.01) = 7.66 \text{ mm}$$



Example 4

The following micrometer screw gauge has $+0.06 \text{ mm}$ of zero error. Determine the reading on the gauge.

Solution:

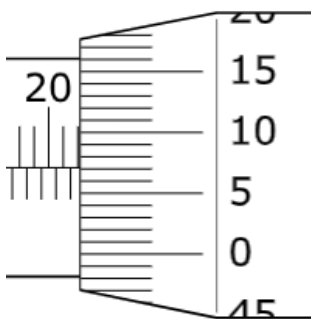

$$\text{Least count} = \frac{0.5}{50} = 0.01 \text{ mm}$$

$$\text{Main scale} = 22.0 \text{ mm}$$

$$\text{Circular scale} = 7 \times 0.01 = 0.07 \text{ mm}$$

$$\text{Obtained reading} = 22.0 + 0.07 = 22.07 \text{ mm}$$

$$\text{True reading} = 22.07 - (+0.06) = 22.01 \text{ mm}$$

Micrometer Screw Gauge



Example 5

The following micrometer screw gauge has -0.03 mm of zero error. Determine the reading on the gauge.

Solution:

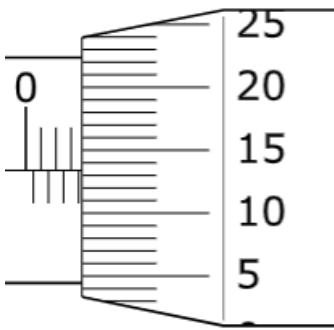

$$\text{Least count} = \frac{0.5}{50} = 0.01 \text{ mm}$$

$$\text{Main scale} = 3.5 \text{ mm}$$

$$\text{Circular scale} = 13 \times 0.01 = 0.13 \text{ mm}$$

$$\text{Obtained reading} = 3.5 + 0.13 = 3.63 \text{ mm}$$

$$\text{True reading} = 3.63 - (-0.03) = 3.66 \text{ mm}$$



Example 6

The following micrometer screw gauge has -0.09 mm of zero error. Determine the reading on the gauge.

Solution:

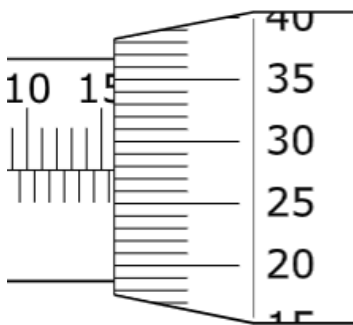

$$\text{Least count} = \frac{0.5}{50} = 0.01 \text{ mm}$$

$$\text{Main scale} = 15.5 \text{ mm}$$

$$\text{Circular scale} = 27 \times 0.01 = 0.27 \text{ mm}$$

$$\text{Obtained reading} = 15.5 + 0.27 = 15.77 \text{ mm}$$

$$\text{True reading} = 15.77 - (-0.09) = 15.86 \text{ mm}$$



Practice Question 4

Determine the reading on the gauge:

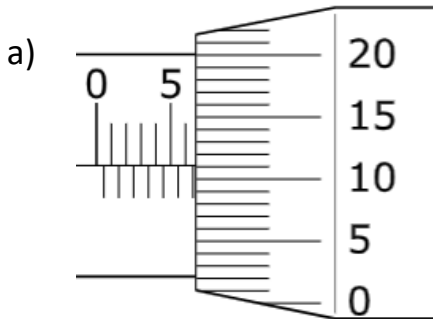

Answer: 6.51 mm

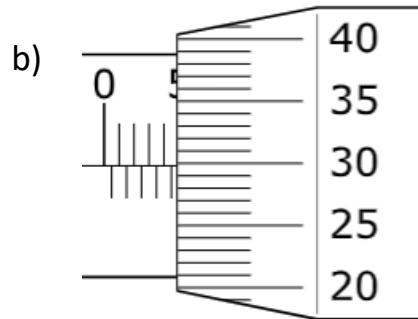

Answer: 4.79 mm

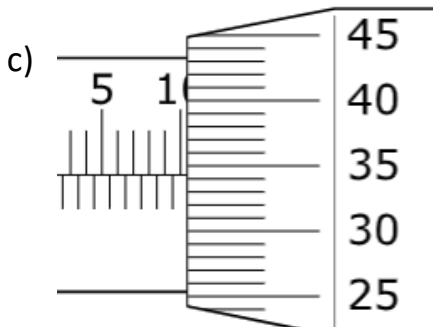

Answer: 10.34 mm

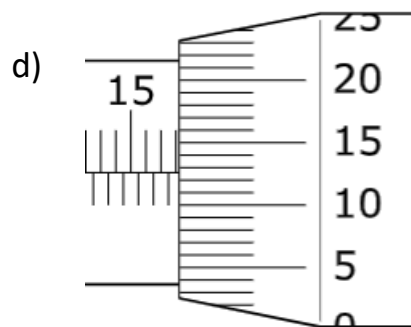

Answer: 18.12 mm

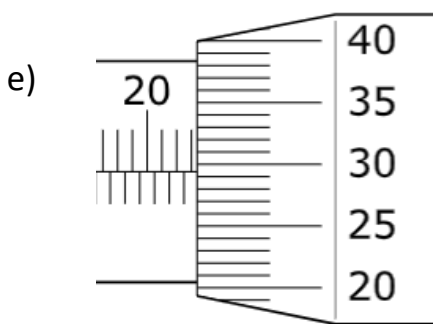

Answer: 23.29 mm

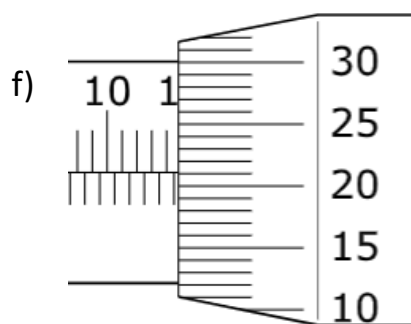

Answer: 14.71 mm



For more exercise on micrometer screw gauge, scan this QR code!

CHAPTER 2

LINEAR MOTION

Learning Outcomes

At the end of this chapter, students should be able to:

- ✓ Define linear motion.
- ✓ Define uniform and non-uniform motion.
- ✓ Describe distance, displacement, speed, velocity, average velocity, acceleration and deceleration.
- ✓ Apply the concept of linear motion in solving the related problems by using formula
- ✓ Illustrate velocity-time graph.
- ✓ Determine the velocity, acceleration and displacement from the graphs.

WRITTEN BY:
FARA NUR ASMA BINTI MOHD BASRI

2.1 APPLY THE CONCEPT OF LINEAR MOTION

2.1.1 LINEAR MOTION

- ❑ Linear motion is a motion along a **straight line**.
- ❑ Linear motion is the most basic of all motion.
- ❑ Differentiate these:

Linear Motion

- Fruits falling from the trees.
- A car moving at the same speed in a straight line.
- A man moving on an escalator.



Non Linear Motion

- A spinning top.
- The rotation and motions of the Earth.
- School of fish swim in the ocean.



2.1.2 UNIFORM AND NON-UNIFORM MOTION

- ❑ The linear motion can be of two types which is:
 - a) A **uniform linear motion** with constant velocity or zero acceleration, and
 - b) A **non-uniform linear motion** with variable velocity or non-zero acceleration.
- ❑ According to Newton's first law of motion, objects that do not experience any net force will continue to move in a straight line with a constant velocity until they are subjected to a net force.
- ❑ The main physical quantities involved in linear motion are distance, displacement, speed, velocity, acceleration and deceleration.

2.1.3 DISTANCE, DISPLACEMENT, SPEED, VELOCITY AND ACCELERATION

- **Distance** and **displacement** are two quantities that may seem to mean the same thing, yet have distinctly different definitions and meanings.

Distance

- Refers to the total length travelled during its motion from one location to another.
- Scalar quantity (which has only a magnitude).
- SI Unit meter (m)
- Example: A student walks a total of 100 meters.



Displacement

- Refers to the distance travelled in a specified direction and the object's overall change in position.
- Vector quantity (which has magnitude and direction).
- SI Unit meter (m)
- Example: A man drives 10 meters to the south and then continues another 20 meters to the west.

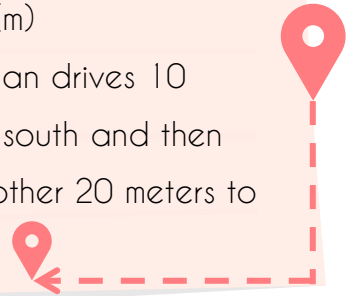

Example 1

Calculate the distance and displacement of the movement from point A to B, C, D and ended at the same point A.

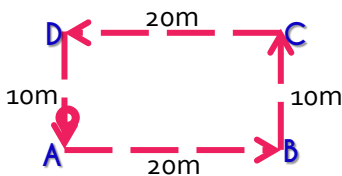

Solution:

$$\begin{aligned} \text{Distance} &= 20 + 10 + 20 + 10 = 60\text{m} \\ \text{Displacement} &= +20 + 10 - 20 - 10 = 0\text{m} \end{aligned}$$

Example 2

Calculate the distance and displacement covered by Alexa if she travels from point X to Z through point Y.

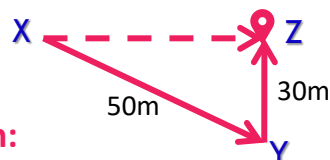

Solution:

$$\text{Distance} = 50 + 30 = 80\text{m}$$

Displacement = distance from P to R in a straight line. We can use the Pythagorean Theorem:

$$XY^2 = XZ^2 + ZY^2$$

$$50^2 = XZ^2 + 30^2$$

$$XZ = \sqrt{50^2 - 30^2} = 40\text{m}.$$

Example 3

What is the distance and the displacement of a marathon participants if they begin at the entrance of KL Tower, run 10 kilometers and finish back at the same spot?

Solution:

The distance is 10km while the displacement of the participants are 0 kilometers. While they have covered a distance of 10 kilometers, they are actually not displaced. They finish where they started. A round-trip motion always has a displacement of 0.



Example 4

Calculate the distance and the displacement of a bus driver who drove around a roundabout with 7m of radius in town.



Solution:

The distance moved by the bus is the circumference of a circle with a radius of 7 meters.

$$\begin{aligned}\text{Circumference} &= 2\pi r \\ &= 2 \times \pi \times 7 \\ &= 43.98\text{m}\end{aligned}$$

The displacement of the bus is zero.

This is because the bus starts from one point and ended up at the same point.

Practice Question 1

An athlete trains at a 400m track. If he runs a complete 5 rounds for training, calculate his distance and displacement.

Ans: Distance = 2000m
Displacement = 0m

Practice Question 2

Lisa walks 200 m to the north and turns back 25m to the south. Calculate the distance and displacement.

Ans: Distance = 225m
Displacement = 175m

**Practice Question 3**

Brian drove 3km to the east and then another 4km to the south. Calculate his total journey and the possible displacement if he drove direct to his desired destination.

Ans: Distance = 7km
Displacement = 5km

**Practice Question 4**

Angela started her morning walk from her house towards a nearby playground which is 500m in distance. She then made a return journey and continued walking past her house for another 800m distance. Calculate Angela's total distance and displacement.

Ans: Distance = 7km
Displacement = 5km

YOU GOT THIS!

- **Speed** and **velocity** - Just as distance and displacement, despite their similarities, speed and velocity also have distinctly different meanings.

Speed

- It refers to the distance travelled in a certain amount of time.
- Speed can also be described as how fast an object is moving.
- Scalar quantity (which has only a magnitude).
- **Speed** = $\frac{\text{distance (m)}}{\text{time (s)}}$
- SI Unit meter (m/s) @ ms^{-1} @ $\frac{\text{m}}{\text{s}}$ @ meter per second.

Velocity

- It refers to the speed of an object in a specified direction.
- Velocity can also be described as the rate at which an object changes its position.
- Vector quantity (which has magnitude and direction).
- **Velocity** = $\frac{\text{displacement (m)}}{\text{time (s)}}$
- SI Unit meter (m/s) @ ms^{-1} @ $\frac{\text{m}}{\text{s}}$ @ meter per second.

Example 1

Figure shows the travel path taken by Lily from point P to point R. She took 300 seconds to reach her destination. Calculate the speed and the velocity experienced by Lily.

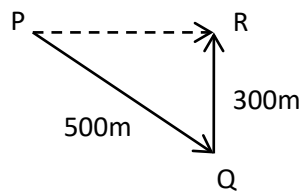

$$\begin{aligned} \text{Speed} &= \frac{\text{distance (m)}}{\text{time (s)}} \\ &= \frac{(500+300)\text{m}}{300\text{ s}} \\ &= 2.67 \text{ ms}^{-1} \end{aligned}$$

$$\begin{aligned} \text{Velocity} &= \frac{\text{displacement (m)}}{\text{time (s)}} \\ &= \frac{400\text{m}}{300\text{ s}} \\ &= 1.33 \text{ ms}^{-1} \end{aligned}$$

Example 2

Roy rides his motorcycle in a straight line for 0.2 km in 0.1 minutes. Calculate his speed in SI unit.

Solution:



$$\begin{aligned} \text{Speed} &= \frac{\text{distance (m)}}{\text{time (s)}} \\ &= \frac{0.2 \text{ km}}{0.1 \text{ min}} \times \frac{1000 \text{ m}}{1 \text{ km}} \times \frac{1 \text{ min}}{60 \text{ sec}} \\ &= 33.33 \text{ ms}^{-1} \end{aligned}$$

Example 3

A car travels 425 km from Seremban to Georgetown, Penang in 5 hours. Calculate the velocity based on this information and give the answer in SI unit.

Solution:

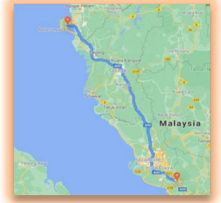

$$\begin{aligned} \text{Speed} &= \frac{\text{distance (m)}}{\text{time (s)}} \\ &= \frac{425 \text{ km}}{5 \text{ hrs}} \times \frac{1000 \text{ m}}{1 \text{ km}} \times \frac{1 \text{ hrs}}{3600 \text{ sec}} \\ &= 23.61 \text{ ms}^{-1} \end{aligned}$$



Average Velocity

- o If an object travels with different velocities all along the movement, then the velocity of the whole journey can be calculated as the *average velocity*. The average velocity can be calculated as:

$$\text{Average velocity} = \frac{\text{total displacement (m)}}{\text{time (s)}}$$

Example 1

Figure shows a path travelled by a cyclist from point X to point Z. Calculate:

- The velocity from X to Y
- The velocity from Y to Z
- The average velocity from start to the end point.



a) Velocity from **x to y**

$$\begin{aligned} &= \frac{\text{displacement (m)}}{\text{time (s)}} \\ &= \frac{300 \text{ m}}{10 \text{ s}} \\ &= 30 \text{ ms}^{-1} \end{aligned}$$

b) Velocity from **y to z**

$$\begin{aligned} &= \frac{\text{displacement (m)}}{\text{time (s)}} \\ &= \frac{100 \text{ m}}{5 \text{ s}} \\ &= 20 \text{ ms}^{-1} \end{aligned}$$

c) average velocity from **x to z**

$$\begin{aligned} &= \frac{\text{total displacement (m)}}{\text{time (s)}} \\ &= \frac{400 \text{ m}}{15 \text{ s}} \\ &= 26.67 \text{ ms}^{-1} \end{aligned}$$

Practice Question 1



Alif rides a motorcycle for 8500 meters that takes 250 seconds. Calculate his speed.

Ans: 34ms^{-1}

Practice Question 2



It took 4 hours for a bus to travel the distance between two cities at a speed of 90 km/hr. What is the distance between the two cities?

Ans: 360 km

Practice Question 3



How long will it take for a car to travel 280 kilometers if it is travelling at a speed of 110 kmhr^{-1}

Ans: 2.55 hr

Practice Question 4



Sarah rides her bicycle for 30 minutes and reaches her destination of 22 kilometers. Calculate her speed for this journey in SI units.

Ans: 12.22ms^{-1}

- **Acceleration and Deceleration.** Acceleration and deceleration are basically opposite behavior. As a brief description, **accelerate means speeding up** while **decelerate means slowing down**.

Acceleration

- Acceleration is defined as the rate at which an object changes its velocity with time.
- It is a measure of how fast the velocity of an object changes in time.
- Vector quantity (which has magnitude and direction).
- Acceleration is experienced by an object if the **velocity increases** with time.
- **Acceleration** = $\frac{\text{change of velocity (ms}^{-1}\text{)}}{\text{time (s)}}$
- Therefore,

$$\text{Acceleration, } \mathbf{a} = \frac{\text{final velocity} - \text{initial velocity}}{\text{time taken}}$$

$$\mathbf{a} = \frac{v - u}{t}$$

- SI unit = ms^{-2} @ m/s^2 @ $\frac{\text{m}}{\text{s}^2}$ @ meter per second²

Deceleration

- Deceleration is the **opposite of acceleration**.
- Deceleration is experienced when an object slows down
- In other words, deceleration happens when the **velocity** of a moving object **decreases** with time.

QUICK TIPS

The formula and units for acceleration and deceleration is the **same**.



Example 1

An athlete is accelerating from an initial velocity of 0 ms^{-1} to a final velocity of 4.5 ms^{-1} in 2 seconds. Calculate his acceleration.

Solution:

Initial velocity, $u = 0 \text{ ms}^{-1}$

Final velocity, $v = 4.5 \text{ ms}^{-1}$

Time taken, $t = 2 \text{ s}$

$$\begin{aligned} \text{Acceleration, } a &= \frac{v-u}{t} \\ &= \frac{4.5-0}{2} \\ &= 2.25 \text{ ms}^{-2} \end{aligned}$$



Example 2

A bus accelerates uniformly from an initial velocity of 3 ms^{-1} to a final velocity of 12 ms^{-1} in 5 seconds. Calculate the acceleration experienced by the bus.

Solution:

Initial velocity, $u = 3 \text{ ms}^{-1}$

Final velocity, $v = 12 \text{ ms}^{-1}$

Time taken, $t = 5 \text{ s}$

$$\begin{aligned} \text{Acceleration, } a &= \frac{v-u}{t} \\ &= \frac{12-3}{5} \\ &= 1.8 \text{ ms}^{-2} \end{aligned}$$



Example 3

A car decelerates uniformly from an initial velocity of 25 ms^{-1} until it stops 7 seconds later at a traffic light. Calculate the deceleration experienced by the car.

Solution:

Initial velocity, $u = 25 \text{ ms}^{-1}$

Final velocity, $v = 0 \text{ ms}^{-1}$

Time taken, $t = 7 \text{ s}$

$$\begin{aligned} \text{Acceleration, } a &= \frac{0-25}{7} \\ &= \frac{-25}{7} \\ &= -3.57 \text{ ms}^{-2} \end{aligned}$$

The negative sign of an acceleration simply means that the car is slowing down. The velocity is decreasing.



Example 4

Cody is riding his bicycle with an initial velocity of 15 ms^{-1} . He applied the brakes and the bicycle decelerates uniformly with 4.7 ms^{-2} until it finally stops. Calculate the time taken for the bicycle to stop in this situation.

Solution:

Initial velocity, $u = 15 \text{ ms}^{-1}$

Final velocity, $v = 0 \text{ ms}^{-1}$

Deceleration = 4.7 ms^{-2}

$$\begin{aligned} \text{Deceleration, } a, -4.2 &= \frac{0-15}{t} \\ t &= \frac{-15}{-4.7} \\ &= 3.19 \text{ s} \end{aligned}$$



Use negative sign because to calculate deceleration, we use the same formula to calculate acceleration.

Example 5

A vehicle accelerates uniformly from an initial velocity of 3ms^{-1} to a final velocity of 11ms^{-1} in 9 seconds. It then slows down uniformly to a final velocity of 2ms^{-1} in 8 seconds. Calculate the acceleration of the vehicle

- during the first 9 seconds and
- during the last 8 seconds.

Solution:

a. During the first 9 seconds

Initial velocity, $u = 3\text{ms}^{-1}$

Final velocity, $v = 11\text{ms}^{-1}$

Time taken, $t = 9\text{s}$

$$\begin{aligned}\text{Acceleration, } \mathbf{a} &= \frac{v-u}{t} \\ &= \frac{11-3}{9} \\ &= 0.89\text{ms}^{-2}\end{aligned}$$

b. During the last 8 seconds

Initial velocity, $u = 11\text{ms}^{-1}$

Final velocity, $v = 2\text{ms}^{-1}$

Time taken, $t = 8\text{s}$

$$\begin{aligned}\text{Acceleration, } \mathbf{a} &= \frac{v-u}{t} \\ &= \frac{2-11}{8} \\ &= -1.125\text{ms}^{-2}\end{aligned}$$

Example 6

During a take-off, an airplane accelerates uniformly from 30kmhr^{-1} to 240kmhr^{-1} in 32 seconds before it lifts off the ground. Calculate the acceleration experienced by the airplane upon taking off. Give your answer in SI units.

Solution:

Initial velocity, $u = 30\text{kmhr}^{-1}$

Convert units to ms^{-1}

$$= \frac{30\text{ km}}{\text{hr}} \times \frac{1000\text{ m}}{1\text{ km}} \times \frac{1\text{ hr}}{3600\text{ sec}} = 8.33\text{ms}^{-1}$$

Final velocity, $v = 240\text{kmhr}^{-1}$

Convert units to ms^{-1}

$$= \frac{240\text{ km}}{\text{hr}} \times \frac{1000\text{ m}}{1\text{ km}} \times \frac{1\text{ hr}}{3600\text{ sec}} = 66.67\text{ms}^{-1}$$

Time taken, $t = 32\text{s}$

$$\begin{aligned}\text{Acceleration, } \mathbf{a} &= \frac{v-u}{t} \\ &= \frac{66.67-8.33}{32} \\ &= 1.823\text{ms}^{-2}\end{aligned}$$

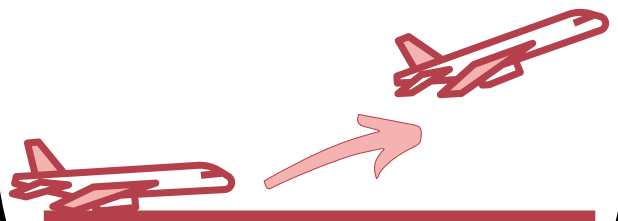

Practice Question 1

A car accelerates from 10kmhr^{-1} to 110kmhr^{-1} in 15 seconds. Find the acceleration in SI unit.

Ans: 1.852ms^{-2}

Practice Question 2

An aircraft initially at rest accelerates at 2.51ms^{-2} in 32 seconds upon taking off. What is its final velocity for this movement?

Ans: 80.32ms^{-1}

Practice Question 3

A train starts from rest accelerates uniformly at 3.3ms^{-2} and reach its final velocity of 41ms^{-1} . How long is the duration of this movement?

Ans: 12.42s

Practice Question 4

A car with an initial velocity of 65kmhr^{-1} takes 15 seconds to change its velocity to 12kmhr^{-1} . Is this car experienced an acceleration or deceleration? Provide your answer with a calculation using suitable formula.

Ans: -0.982ms^{-2}

2.1.4 KINEMATIC FORMULA

- Problems related to uniformly accelerated motions can be solved using the kinematic formula.

KINEMATIC FORMULA

i. $v = u + at$

ii. $v^2 = u^2 + 2as$

iii. $s = ut + \frac{1}{2} at^2$

iv. $s = \frac{1}{2} (u + v) t$

Variables used in the equations:

u = initial velocity

v = final velocity

t = time

a = acceleration

s = displacement

How do we choose a kinematic formula?



To choose which kinematic formula to use in solving a particular question, we can follow these simple steps:

1. List down all the variables given in the question
2. Identify which variable that we need to find
3. Choose suitable kinematic formula according to (1) and (2).
4. Rearrange the formula (if necessary)





Example 1

A cyclist is travelling at a constant velocity of 3.1 ms^{-1} . He suddenly accelerates at 0.65 ms^{-2} for 16 meters. Calculate his final velocity.

Solution:

List down all the variables given:

Initial velocity, $u = 3.1 \text{ ms}^{-1}$
 acceleration, $a = 0.65 \text{ ms}^{-2}$
 displacement, $s = 16 \text{ m}$

Which variable that we need to find?

final velocity, v ?

So we have u , a and s . And we need to find v .

$$\begin{aligned} v^2 &= u^2 + 2as \\ &= (3.1)^2 + 2(0.65)(16) \\ v &= \sqrt{30.41} \\ &= 5.51 \text{ ms}^{-1} \end{aligned}$$



Example 2

A car slows down from a velocity of 15 ms^{-1} to 2 ms^{-1} in 8 seconds. Calculate:

- The deceleration.
- The distance travelled in 8 seconds.

Solution:

List down all the variables given:

Initial velocity, $u = 15 \text{ ms}^{-1}$
 Final velocity, $v = 2 \text{ ms}^{-1}$
 time taken, $t = 8 \text{ s}$

So we have u , v and t . We need to find:

- deceleration, a

$$\begin{aligned} a &= \frac{v-u}{t} \\ &= \frac{2-15}{8} \\ &= -1.625 \text{ ms}^{-2} \end{aligned}$$

- distance, s

$$\begin{aligned} s &= \frac{1}{2}(u+v)t \\ &= \frac{1}{2}(15+2)8 \\ &= 68 \text{ m} \end{aligned} \quad \textcircled{a} \quad \begin{aligned} s &= ut + \frac{1}{2}at^2 \\ &= (15)(8) + \frac{1}{2}(-1.625)(8)^2 \\ &= 68 \text{ m} \end{aligned}$$

This question can be solved using any of these two formulas as long as we have the value of related variables. As in example 2(a) the value of acceleration is obtained so it can be used to answer example 2(b).

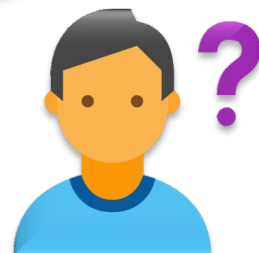



Example 3

A man drove a car travelling at 105 km/hr decelerates uniformly at 3 ms^{-2} upon seeing a red traffic light and later comes to a halt. Calculate:

- The time taken upon this deceleration process.
- The distance travelled between the point where the brakes initially applied and the point where the car stops.

Solution:

List down all the variables given:

Initial velocity, $u = 105 \text{ km/hr}$

Final velocity, $v = 0 \text{ ms}^{-1}$

acceleration, $a = -3 \text{ ms}^{-2}$

Conversion of units:

$$\begin{aligned} 105 \text{ kmhr}^{-1} &= \frac{105 \text{ km}}{\text{hr}} \times \frac{1000 \text{ m}}{1 \text{ km}} \times \frac{1 \text{ hr}}{3600 \text{ sec}} \\ &= 29.17 \text{ ms}^{-1} \end{aligned}$$

So we have u , v and a . We need to find:

- The time taken upon this deceleration process.

$$a = \frac{v - u}{t}$$

$$\begin{aligned} t &= \frac{0 - 29.17}{-3} \\ &= 9.72 \text{ s} \end{aligned}$$

- Distance travelled, s

$$v^2 = u^2 + 2as$$

$$0 = (29.17)^2 + 2(-3)s$$

$$s = \frac{-850.89}{-6}$$

$$= 141.81 \text{ m}$$

IMPORTANT

Be **alert with the units** provided for the variables.

To insert these variables into a formula, the **units must be in uniform condition**, preferably in SI units.

Therefore, a **conversion of units** might be needed before we solve the question.

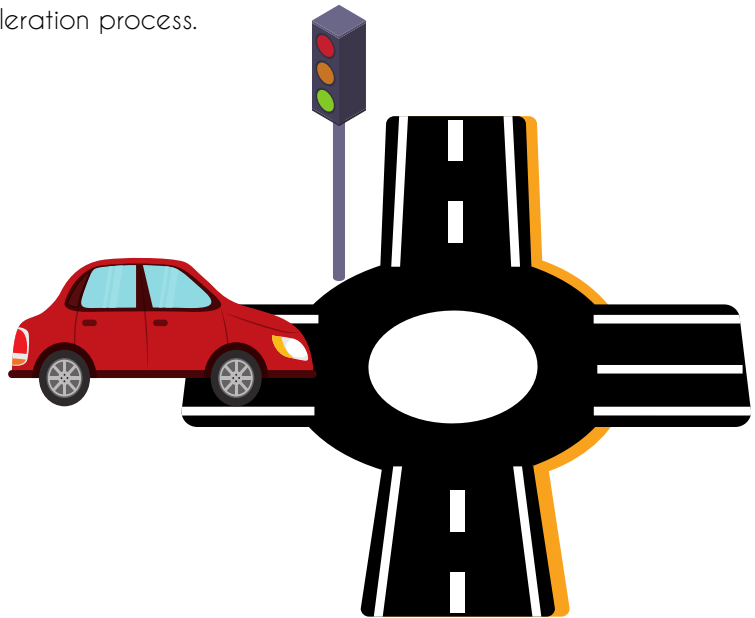



Example 4

A ball is released free fall from the height of 5 meters. Calculate:

- The final velocity just before it hits the ground.
- The time taken for the ball to reach the ground.

Solution:

List down all the variables given:

Initial velocity, $u = 0 \text{ ms}^{-1}$

acceleration, $a = 9.81 \text{ ms}^{-2}$

displacement, $s = 5 \text{ m}$

The initial velocity of the ball is zero since initially it was in a static position.

Every free falling objects experienced an acceleration of 9.81 ms^{-2} (positive value) which is due to the gravitational acceleration downwards.

So we have u , a and s . We need to find:

- The final velocity just before it hits the ground.

$$\begin{aligned} v^2 &= u^2 + 2as \\ &= 0 + 2(9.81)(5) \\ &= \sqrt{98.1} \\ &= 9.91 \text{ ms}^{-1} \end{aligned}$$

- The time taken for the ball to reach the ground

$$\begin{aligned} v &= u + at \\ 9.91 &= 0 + (9.81)t \\ t &= 1.01 \text{ s} \end{aligned}$$

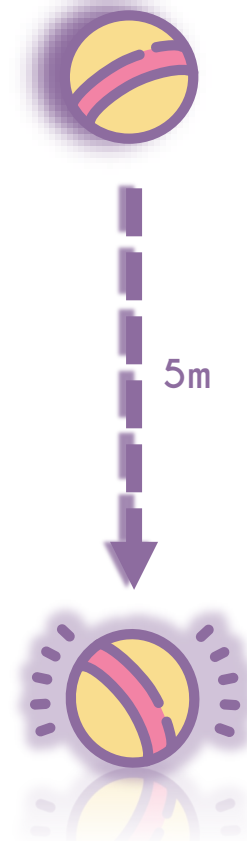



Example 5

An object is placed on a 10m height platform. It was then released free fall down as shown in the figure below. Calculate the velocity and the time taken at positions B, C and D.

Solution:

Note that at position B, the height is 7m from the ground. This means that the object has travelled 3 meters from its initial position.

So at position B;

$$\begin{aligned} u &= 0 \text{ ms}^{-1} \\ a &= 9.81 \text{ ms}^{-2} \\ s &= 3\text{m} \end{aligned}$$

The velocity:

$$\begin{aligned} v^2 &= u^2 + 2as \\ &= 0 + 2(9.81)(3) \\ &= \sqrt{58.86} \\ &= \underline{7.67 \text{ ms}^{-1}} \end{aligned}$$

Time taken:

$$\begin{aligned} v &= u + at \\ 7.67 &= 0 + (9.81)t \\ \therefore t &= 7.67/9.81 \\ &= \underline{0.78 \text{ s}} \end{aligned}$$

Note that at position C, the height is 4m from the ground. This means that the object has travelled 6 meters from its initial position.

So at position C;

$$\begin{aligned} u &= 0 \text{ ms}^{-1} \\ a &= 9.81 \text{ ms}^{-2} \\ s &= 6\text{m} \end{aligned}$$

The velocity:

$$\begin{aligned} v^2 &= u^2 + 2as \\ &= 0 + 2(9.81)(6) \\ &= \sqrt{117.72} \\ &= \underline{10.85 \text{ ms}^{-1}} \end{aligned}$$

Time taken:
Try using another formula to obtain the value of t.

$$\begin{aligned} s &= ut + \frac{1}{2}at^2 \\ 6 &= (0)t + \frac{1}{2}(9.81)t^2 \\ \therefore t^2 &= \frac{6}{4.905} \\ t &= \sqrt{1.223} \\ &= \underline{1.11 \text{ s}} \end{aligned}$$

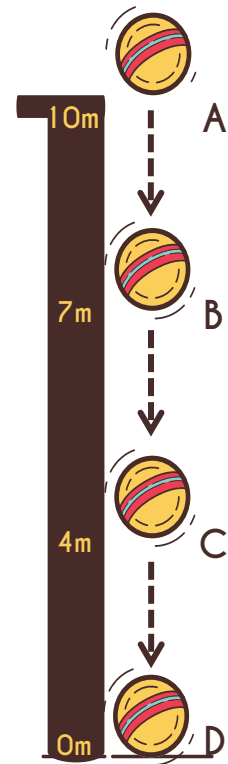

Note that at position D, the height is zero meter from the ground. This means that the object has travelled 10 meters from its initial position.

So at position D;

$$\begin{aligned} u &= 0 \text{ ms}^{-1} \\ a &= 9.81 \text{ ms}^{-2} \\ s &= 10\text{m} \end{aligned}$$

The velocity:

$$\begin{aligned} v^2 &= u^2 + 2as \\ &= 0 + 2(9.81)(10) \\ &= \sqrt{196.2} \\ &= \underline{14.01 \text{ ms}^{-1}} \end{aligned}$$

Time taken:
Try using another formula to obtain the value of t.

$$\begin{aligned} s &= \frac{1}{2}(u + v)t \\ 10 &= \frac{1}{2}(0 + 14.01)t \\ \therefore t &= \frac{10(2)}{14.01} \\ &= \underline{1.43 \text{ s}} \end{aligned}$$



Example 6

A stone is thrown vertically upwards with an initial velocity of 10 ms^{-1} . Calculate the time taken and the total distance of the stone to go up and down the same height it was thrown.

Solution:

In this condition, an object thrown **upwards** experiences a **decreasing in velocity** (assuming there are no external forces acting on it, and neglecting the air friction). Therefore, the acceleration is negative when it moves upwards.

When it comes down, the velocity will increase and this means the acceleration is a positive value. Thus, we can divide the situation into 2 conditions:

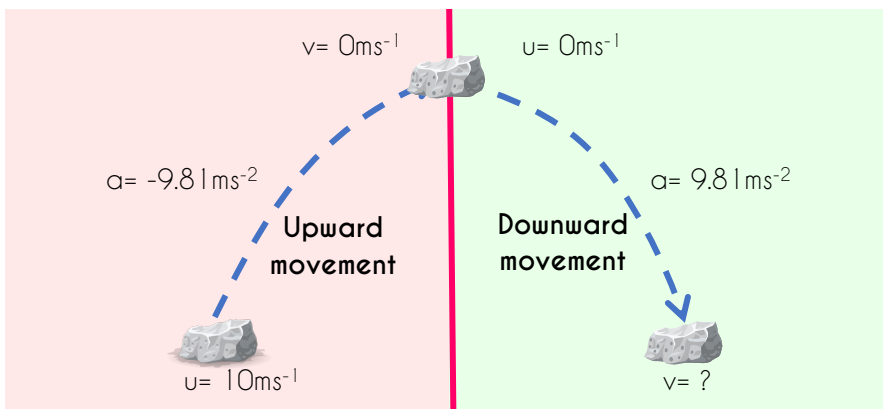

Upward movement:

The stone thrown upwards will pause for a moment at the highest point of its travel before it falls again. Therefore, the final velocity for this movement is zero.

So we can use the formula:

$$\begin{aligned} v &= u + at \\ 0 &= 10 + (-9.81)t \\ -10 &= -9.81t \\ \text{So } t &= (-10)/(-9.81) \\ &= \underline{1.019 \text{ s}} \end{aligned}$$

$$\begin{aligned} \text{Distance } s, &= ut + \frac{1}{2}at^2 \\ &= (10)(1.019) + \frac{1}{2}(-9.81)(1.019)^2 \\ &= \underline{5.097 \text{ m}} \end{aligned}$$

Downward movement:

Upon the downward movement of the stone, the initial velocity is zero. The distance traveled by the stone when thrown upwards is the **same distance as it travels back down**.

Using the same distance, we can find the time taken for the stone to fall back down. Now the initial velocity of this movement will be zero.

$$\begin{aligned} s &= ut + \frac{1}{2}at^2 \\ 5.097 &= (0)(t) + \frac{1}{2}(9.81)t^2 \\ t^2 &= \frac{5.097}{4.905} \\ t &= \sqrt{1.039} \\ &= \underline{1.019 \text{ s}} \end{aligned}$$

Practice Question 1

A motorcycle travelling at 15 ms^{-1} stops after a distance of 150m. Calculate:

- The deceleration
- The time taken for it to stop.

Ans: a) 0.75 ms^{-2} b) 0.75 s

Practice Question 2

An object which initially at rest, moves in a straight line with uniform acceleration and covers 0.7 km in 1.8 minutes. Calculate:

- The acceleration, and
- The final velocity of the object.

Give your answers in SI units.

Ans: a) 0.12 ms^{-2} b) 12.96 ms^{-1}

Practice Question 3

A mango falls from its tree to the ground with an acceleration of 9.81 ms^{-2} for 0.8 seconds. Calculate:

- The height from where the mango falls.
- The final velocity just before it hits the ground.

Ans: a) 3.14 m b) 7.85 ms^{-1}

Practice Question 4

A boy throws a ball vertically upwards with an initial velocity of 3 ms^{-1} . Calculate the time taken for the ball to go up and come down again with the same height it travels.

Ans: 0.612 s

2.2 THE VELOCITY - TIME GRAPH

- The Velocity - Time graph is a linear graph showing how the velocity of an object changes with time.
- The **gradient** of graph indicates the **acceleration** of movement.
Acceleration, $a = \text{gradient of graph}$
- The **area under the graph** indicates the **distance** travelled for the movement.
Distance, $s = \text{Area under the graph}$

The Velocity - Time Graph in details

Uniform acceleration

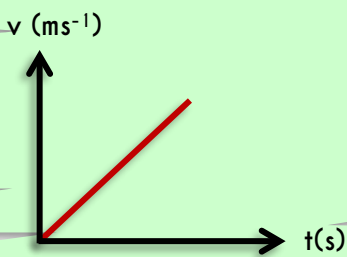

1. **Velocity:** Increases uniformly over a period of time.
2. **Acceleration:** Positive

Uniform velocity

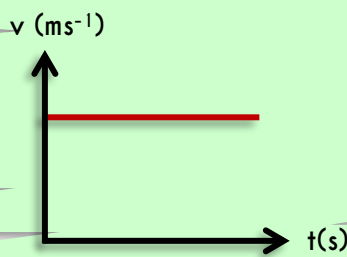

1. **Velocity:** Constant over a period of time.
2. **Acceleration:** Zero

Uniform deceleration

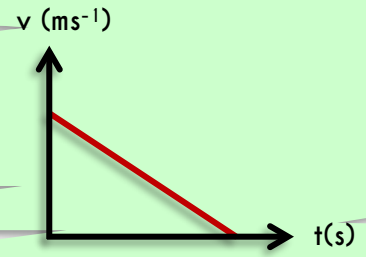

1. **Velocity:** Decreases uniformly over a period of time.
2. **Acceleration:** Negative

- If the graph shows that there is a negative value in v (as in the N area) this means that the whole M area, the object moves in positive direction while area N shows that the object moves in negative direction.

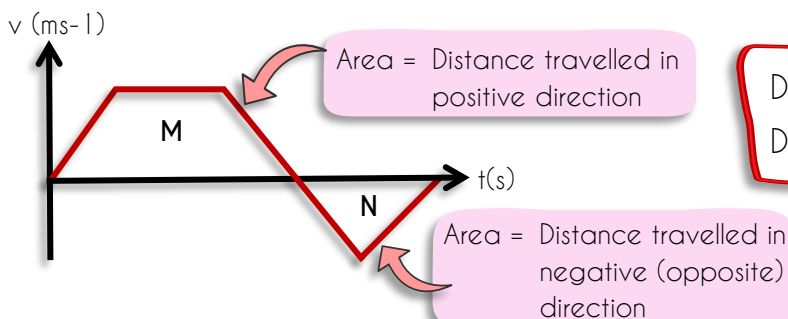

NOTES

$$\begin{aligned} \text{Distance} &= \text{Area M} + \text{Area N} \\ \text{Displacement} &= \text{Area M} - \text{Area N} \end{aligned}$$

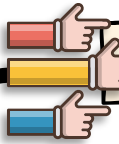

Example 1

The graph below shows the motion of a car on a straight road.

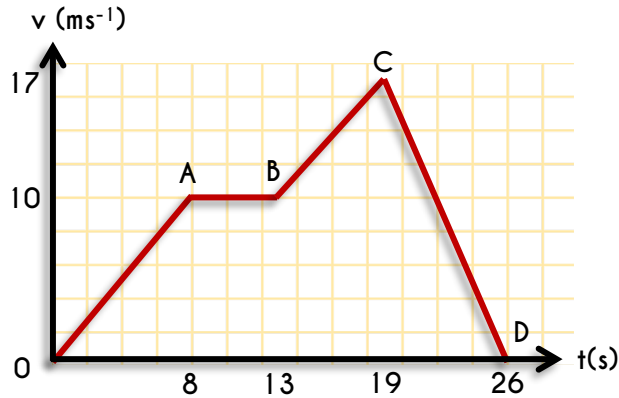

- Describe the motion of the car represented by line OA, AB, BC and CD
- Calculate the acceleration at point OA and BC
- Calculate the deceleration at point CD
- Calculate the total distance travelled for the whole 26 seconds movement.

Solution:

- OA = Uniform acceleration
AB = Uniform velocity
BC = Uniform acceleration
CD = Uniform deceleration

- Acceleration at Point OA:

$a = \text{gradient of graph}$

$$= \frac{\Delta y}{\Delta x}$$

$$a = \frac{10 - 0}{8 - 0}$$

$$= \underline{1.25 \text{ ms}^{-2}}$$

- Acceleration at Point BC:

$a = \text{gradient of graph}$

$$= \frac{\Delta y}{\Delta x}$$

$$a = \frac{17 - 10}{19 - 13}$$

$$= \underline{1.17 \text{ ms}^{-2}}$$

- deceleration at point CD

$a = \text{gradient of graph}$

$$= \frac{\Delta y}{\Delta x}$$

$$a = \frac{0 - 17}{26 - 19}$$

$$= \underline{-2.43 \text{ ms}^{-2}}$$

- Total distance travelled

Total distance = area under the graph

Divide the area into easier shapes

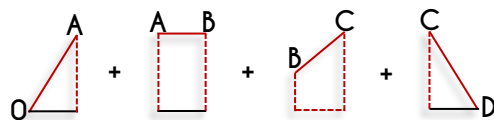

$$= \left[\frac{1}{2} \times 10 \times 8 \right] + [10 \times 5] + \left[\frac{10+17}{2} \times 6 \right] + \left[\frac{1}{2} \times 17 \times 7 \right]$$

$$= 40 + 50 + 81 + 59.5$$

$$= \underline{230.5 \text{ m}}$$

Practice Question 1

The graph below shows the velocity-time graph of an object.

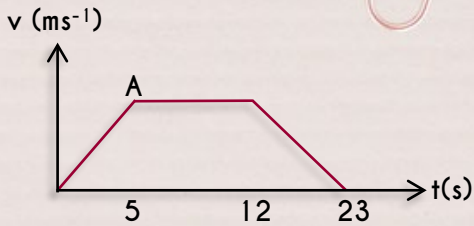

Calculate:

- The velocity at point A if its acceleration is 1.5 ms^{-2} .
- The deceleration right before it stops.
- The distance of the whole movement.

Ans: a) 7.5 ms^{-1} b) -1.25 ms^{-2} c) 112.5 m

Practice Question 2

A car starts from rest and accelerates at a constant acceleration of 2.3 ms^{-2} for 10 seconds. The car then travels at a constant velocity for 5 seconds. The brakes are then applied and the car stops in 8 seconds.

- What is the maximum velocity of the car in this movement?
- Plot the velocity - time graph for this movement.
- Calculate the total distance travelled.

Ans: a) 23 ms^{-1} b) c) 322 m

Practice Question 3

A vehicle decelerates uniformly from 20 ms^{-1} to 10 ms^{-1} in a distance of 100 meters.

- Sketch a velocity - time graph for this process.
- Use the graph to determine the duration that is needed for the vehicle to slow down.

Ans: a) b) 6.67 s

Practice Question 4

A moving car initially decelerates from 30 ms^{-1} to 10 ms^{-1} in 10 seconds. The car then moves with uniform velocity for 7 seconds and finally accelerates for 5 seconds to reach a velocity of 25 ms^{-1} .

- Sketch the velocity - time graph for this movement.
- Calculate the acceleration of the car.
- Calculate the deceleration of the car.
- Calculate the total distance travelled for this whole journey.

Ans: a) b) 3 ms^{-2} c) -2 ms^{-2} d) 357.5 m

2.3 EXPERIMENT RELATED TO LINEAR MOTION

- ❑ A common way to analyze the motion of an object is to use a ticker timer and a ticker tape.
- ❑ A ticker timer is usually connected to an alternating current (A.C) power supply.
- ❑ With a frequency of 50 Hz (hertz), it makes 50 dots per second on a ticker tape.

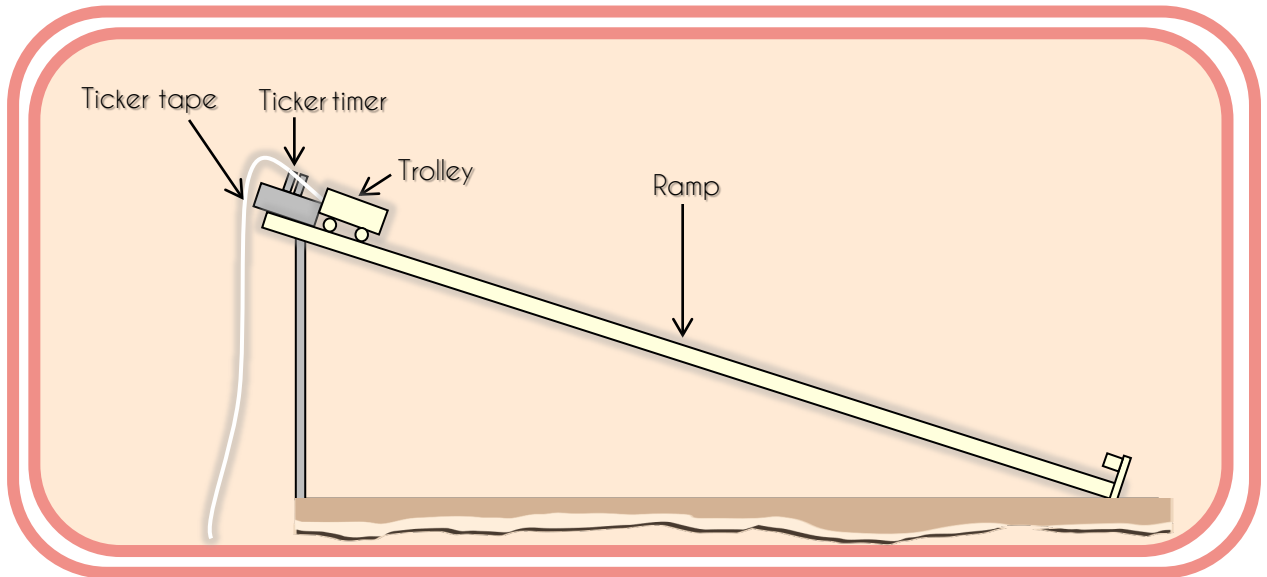

- ❑ By setting up the apparatus as illustrated above and perform the laboratory test, as a result, there will be several dots on the ticker tape.
- ❑ The time interval between two dots or 1 tick is 0.02 seconds.

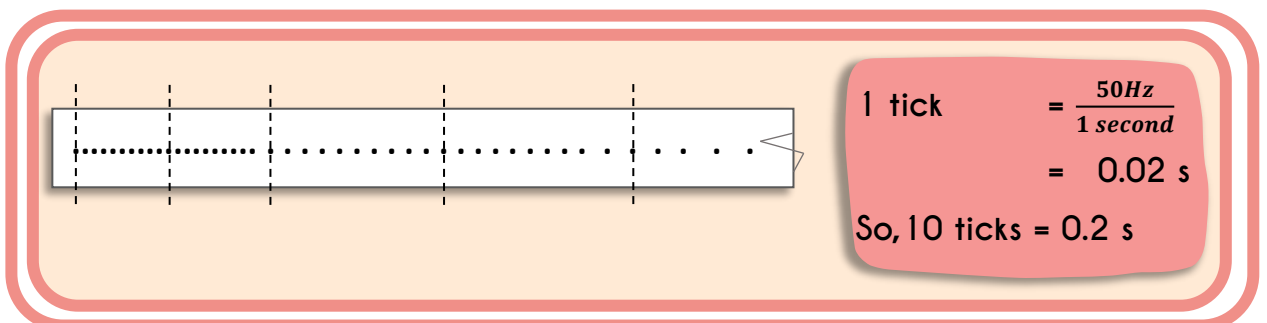

- ❑ To analyze the motion of the trolley rolling down the ramp, a ticker tape is usually divided by a few strips, **each strip shows 10 ticks.**
- ❑ These strips will be arranged accordingly and it forms **a ticker tape chart.**

- From a ticker tape chart:
 - i. A Displacement vs Time chart can be formed.
 - ii. We can see that the distance between the dots increase with time.
 - iii. The length of the ticker tape strips increases uniformly.
 - iv. We can determine the displacement, velocity and acceleration of the trolley

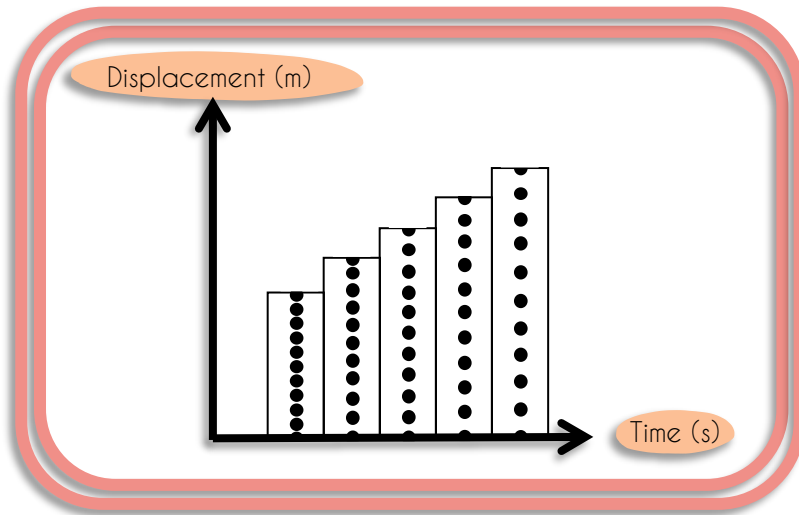

| | | |
|----|---|------------------------|
| 1 | Number of 10 dot strips | 5 |
| 2 | Total time, $t_{\text{total}} = \text{number of strips} \times 0.2$ | 1 s |
| 3 | Total displacement of the trolley (total length of all strips) | 0.85 m |
| 4 | Average velocity of the trolley | 0.85 m/s |
| | $v = \frac{\text{total displacement}}{\text{total time}} = \frac{0.85}{1}$ | |
| 5 | Acceleration of the trolley | |
| a. | Initial velocity | 0.125 m/s |
| | $u = \frac{\text{length of first strip}}{\text{time for 10 dots}} = \frac{0.025}{0.2}$ | |
| b. | Final velocity | 1.13 m/s |
| | $v = \frac{\text{length of last strip}}{\text{time for 10 dots}} = \frac{0.226}{0.2}$ | |
| c. | Time for acceleration, t (number of strips - 1) x (time for 10 dots) $= (5 - 1) \times 0.2$ | 0.8 s |
| d. | Acceleration | 1.256 m/s ² |
| | $a = \frac{v-u}{t} = \frac{1.13 - 0.125}{0.8}$ | |

EXERCISE

For more *exercise* on Linear Motion,
please scan the QR Code below:



CHAPTER 3

“FORCE”

The word 'FORCE' is written in a large, white, outlined font. Two simple stick figures are positioned on either side of the word. The figure on the left is pushing against the letter 'F', and the figure on the right is pushing against the letter 'E'. The word is enclosed in quotation marks.

Learning Objectives

Upon completion of this topic, students should be able to :

- Define force and its unit
- State the effect of force
- Differentiate between weight and mass
- Define Newton's Law
- Define force in equilibrium
- Calculate resultant force using resolution method
- Apply the concept of force in solving problems related to the equilibrium of forces
- Define moment of force and its unit
- Describe principle of moment of force
- Apply the concept and formula of moment of force in solving the related problems

WRITTEN BY:
MOHD SAIFUL BIN PAHRUDIN

3.1 Apply the concept of force

3.1.1 Define force and its units

FORCE

Definition(s)

- It is an action to push or pull , one objects on another object
- It is an action that alters the state of motion of a body in a straight line

Formula

$$F = m \times a$$

F = force
m = mass
a = acceleration

$$W = m \times g$$

W = weight
m = mass
g = gravity

*If the force acting on the object due to the gravity, it is known as **weight**.*

$$F = W = m \times g$$

Unit

kg.m/s² or Newton (N)

Physical Quantity

Derived quantity & Vector quantity

A change of state of motion means a change in either the speed of an object or its direction of motion or both

TIPS

3.1.2 Identify the type of force

Forces are classified as :

- i. **Contact forces** – a force that can be applied only when it is in contact with an object
- ii. **Non-contact forces** – a force that can be applied without any contact with two objects

| | | |
|--------------------|---------------------|---|
| CONTACT FORCES | FRictional FORCE | the force exerted by a surface as an object moves across it or makes an effort to move across it |
| | TENSION FORCE | a force that is transmitted through a string, rope, cable or wire when it is pulled tight by forces acting from opposite ends. |
| | NORMAL FORCE | the support force exerted upon an object that is in contact with another stable object |
| | APPLIED FORCE | a force that is applied to an object by a person or another object |
| | SPRING FORCE | the force exerted by a compressed or stretched spring upon any object that is attached to it |
| | BUOYANT FORCE | this upward force exerted on objects submerged in fluids |
| NON-CONTACT FORCES | GRAVITATIONAL FORCE | the force with which the earth, moon, or other massively large object attracts another object towards itself. (Also known as WEIGHT) |
| | ELECTRICAL FORCE | the repulsive or attractive interaction between any two charged bodies |
| | MAGNETIC FORCE | attraction or repulsion that arises between electrically charged particles because of their motion |

3.1.3 State the effect of the nett force



change the speed of an object



change the shape of an object

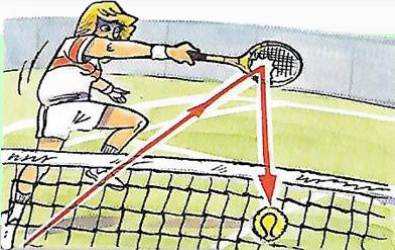

change the direction of motion of an object

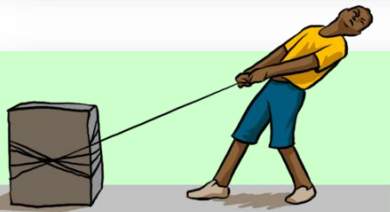

can move a stationary object



can stop a moving object

3.1.4 Newton's Law

Newton's First Law

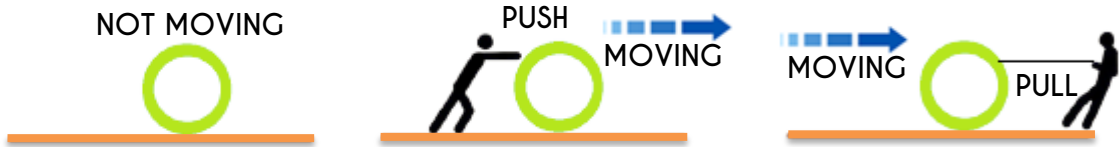

"An object at rest will remain at rest, forever, as long as nothing pushes or pulls it away. And an object in motion will remain in motion, travelling in a straight line, forever, until something pushes or pulls on it."

Newton's Second Law



"The force acting on an object is equal to the mass of that object times its acceleration"

$$F \text{ (force)} = m \text{ (mass)} \times a \text{ (acceleration)}$$

Newton's Third Law



"For every action, there will be an equal and opposite reaction"

$$F(\text{action}) = F(\text{reaction})$$

**EXAMPLE 1**

A motorcycle with a mass of 150kg accelerates at a rate of 30m/s^2 . Calculate the force acting on the motorcycle.

Answer:

$$m = 150 \text{ kg}$$

$$a = 30\text{m/s}^2$$

$$F = m \times a$$

$$= (150) \times (30) = \mathbf{4500\text{N}}$$

**EXAMPLE 2**

Two value of forces is given to Box A and B respectively. It caused both boxes to move at the same acceleration at 2m/s^2 . Find the value of mass for each box A and B, and caused both boxes to accelerate at 2m/s^2 . IF the value of force and Find the value of mass for both box A and B.

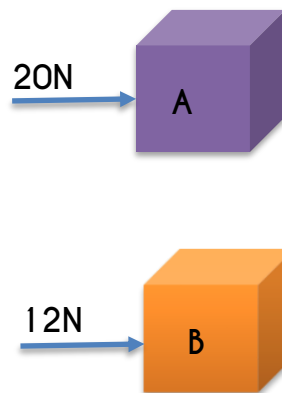

Answer:

Box A

$$F = 20\text{N}$$

$$a = 2\text{m/s}^2$$

$$F = m \times a$$

$$m = \frac{F}{a}$$

$$m = \frac{20}{2} = \mathbf{10\text{kg}}$$

Box B

$$F = 12\text{N}$$

$$a = 2\text{m/s}^2$$

$$F = m \times a$$

$$m = \frac{F}{a}$$

$$m = \frac{12}{2} = \mathbf{6\text{kg}}$$

**EXAMPLE 3**

What is the net force required to accelerate $2 \times 10^6 \text{g}$ of car at 5m/s^2 .
(Neglect the friction force)

Answer:

$$m = 2 \times 10^6 \text{g} = 2000 \text{kg}$$

$$a = 5 \text{m/s}^2$$

$$\begin{aligned} F &= m \times a \\ &= (2000) \times (5) = \mathbf{10000 \text{N}} = \mathbf{10 \text{kN}} \end{aligned}$$

**EXAMPLE 4**

A car is moving from its rest and gain a speed of 80km/hr in 60s .
Given the mass of the car is $2.5 \times 10^3 \text{kg}$. Calculate:

- Acceleration of the car.
- The net force.

Answer:

$$\text{i. } v_f = 80 \text{km/hr}, v_i = 0 \text{ (rest)}$$

$$t = 60 \text{s}$$

$$v_f = 80 \times 1000 \times \frac{1}{60} \times \frac{1}{60} = 22.2 \frac{\text{m}}{\text{s}}$$

$$a = \frac{(v_f - v_i)}{t} = \frac{(22.2 - 0)}{60} = \mathbf{0.37 \text{m/s}^2}$$

$$\text{ii. } m = 2.5 \times 10^3 \text{g} = 2500 \text{kg}$$

$$a = 0.37 \text{m/s}^2$$

$$\begin{aligned} F &= m \times a \\ &= (2500) \times (0.37) \\ &= \mathbf{925 \text{N}} \end{aligned}$$

TIPS

The state of **REST** is considered to be a state of **zero speed**

**PRACTICE QUESTIONS 1**

A girl pushes a table on a horizontal surface with a force of 45N. What is the acceleration of the table being pushed, if the mass of the table is 8kg?

Answer: 5.63m/s^2

**PRACTICE QUESTIONS 2**

A group of 3 boys run towards a 25kg cart, at rest. The force causes the cart to accelerate at 10m/s^2 . Find the value of the force.

Answer: 250N

**PRACTICE QUESTIONS 3**

A customer pushes a trolley with a mass of 9kg with a constant acceleration of 3.2m/s^2 . Calculate:

- i. Force generated by the customer.
- ii. The acceleration, if 15kg of items are loaded on the trolley, and the same value of force is applied.

Answer: i. 28.8N
ii. 1.2m/s^2

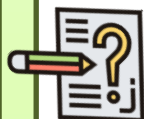
**PRACTICE QUESTIONS 4**

Given a mass of an object is 75kg.

- i. What is the weight of the object.
- ii. What is the weight of the object if it is placed on Mars.
(Gravity of earth = 9.81m/s^2 , Gravity of Mars = 3.721m/s^2)

Answer: i. 735.75N
ii. 279.08N

3.1.5 Describe between weight and mass

Mass

- a measure of how much matter there is in a body
- constant quantity and does not change of position or location

Weight

- the measure of the heaviness of an object
- variable quantity and change with the change in position and location due to the gravity

Differences between weight and mass

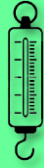
| |  MASS |  WEIGHT |
|----------------------------|---|--|
| Definition | A measure of how much matter there is in a body | The measure of the heaviness of an object |
| SI Unit | kilogram, kg | Newton, N |
| Symbol | mass, m | weight, W |
| Physical Quantities | Scalar Quantity Base Quantity | Vector Quantity Derive Quantity |
| Effect of Gravity | Not affected by gravity, and mass is always constant at any place and time | The weight of an object depends on the gravity at that particular place |

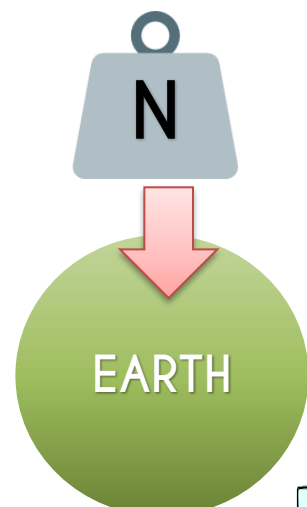

3.1.6 Define forces in equilibrium

BALANCED and UNBALANCED FORCES

- **BALANCED FORCES**

- does not cause any change in motion
- the net force acting on an object is ZERO ($F_{net} = 0$)

- **UNBALANCED FORCES**

- always causes changes a change in motion
- there is a value of net force acting on an object (F_R)

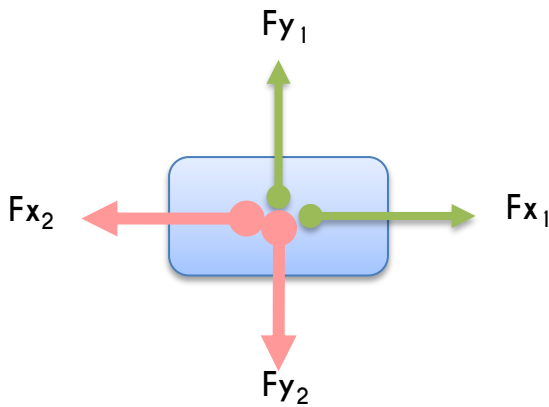

TIPS
A body is in **EQUILIBRIUM** if it does **NOT MOVE**

OBJECT IN EQUILIBRIUM

'The resultant/net force acting on an object is equal to ZERO'

| | |
|--|--|
| | <p>Sum of all horizontal components of the forces is equal to zero</p> <p>Horizontal component $F_{x1} = F_{x2}$</p> <p>Therefore, $F_{x1} - F_{x2} = 0$</p> |
| | <p>Sum of all vertical components of the forces is equal to zero</p> <p>Vertical component $F_{y1} = F_{y2}$</p> <p>Therefore, $F_{y1} - F_{y2} = 0$</p> |

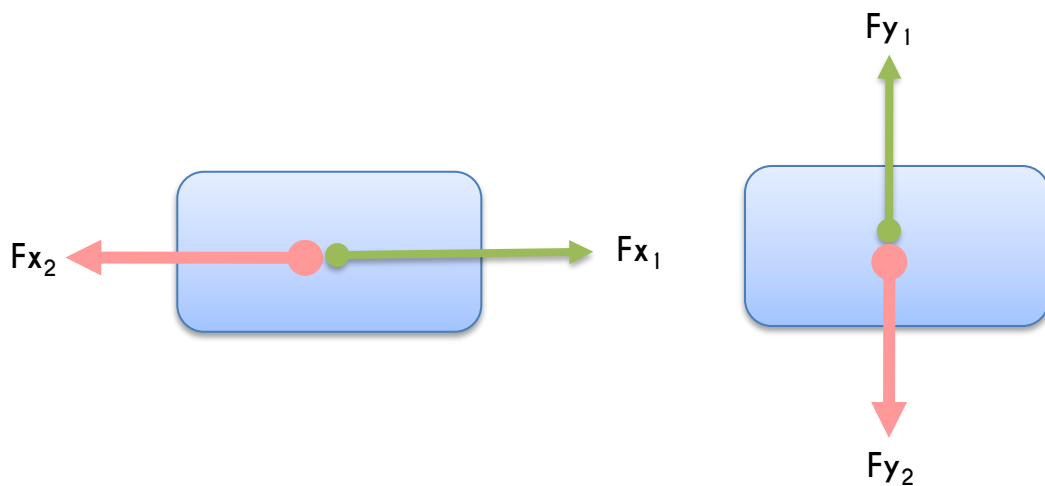

| | |
|--|--|
| Horizontal component Resultant Force, $F_R = F_{x1} - F_{x2} = 0$ | Vertical component Resultant Force, $F_R = F_{y1} - F_{y2} = 0$ |
|--|--|



EXAMPLE

Calculate the value of 'x', if the box is in balanced condition.

Answer:

$$F_R = F_{x1} - F_{x2} = 0$$

$$x - (10 + 4) = 0$$

$$x = 14N$$

Answer:

$$F_R = F_{x1} - F_{x2} = 0$$

$$17 - (x + 15) = 0$$

$$x = 2N$$

Answer:

$$F_R = F_{y1} - F_{y2} = 0$$

$$20 - x = 0$$

$$x = 20N$$

Answer:



$$F_R = F_{y1} - F_{y2} = 0$$

$$(x + 15) - 23 = 0$$

$$x = 8N$$

**EXAMPLE**

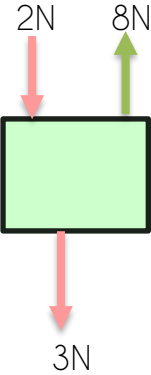
Find the resultant forces

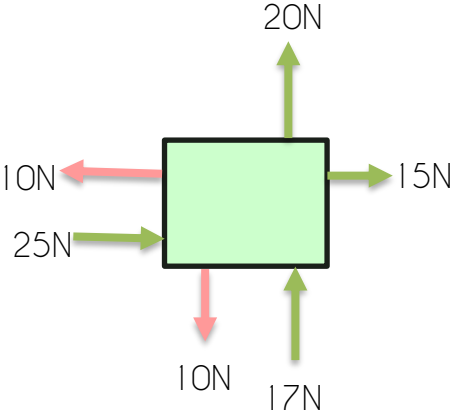
| | |
|---|--|
|  | $F_R = F(\text{upward}) + F(\text{downward})$ $F_R = 8 + (-2) + (-3)$ $= 3\text{N (upward)}$ |
|  | $F_R = F(\text{right}) + F(\text{left})$ $F_R = 30 + 10 + (-15) + (-20)$ $= 5\text{N (to the right)}$ |
|  | <p>Vertical components</p> $F_R = F(\text{upward}) + F(\text{downward})$ $F_R = 20 + 17 + (-10)$ $= 27\text{N (upward)}$ <p>Horizontal components</p> $F_R = F(\text{right}) + F(\text{left})$ $F_R = 15 + 25 + (-10)$ $= 30\text{N (to the right)}$ |

3.1.7 Calculate resultant force by using resolution method

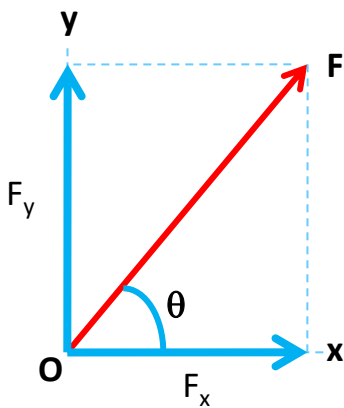

Resultant force is a single force that can be resolved into two perpendicular components

F_x = Horizontal vector component

F_y = Vertical vector component

F = Resultant Force (The force, F at the angle of θ)

| | |
|----------------------------|-------------------------|
| $F_x = F \cdot \cos\theta$ | $\cos \theta = F_x / F$ |
| $F_y = F \cdot \sin\theta$ | $\sin \theta = F_y / F$ |

| | |
|--|----------------------|
| | Horizontal component |
| | Vertical component |

Horizontal component

$$F_x = F \cdot \cos\theta$$

Vertical component

$$F_y = F \cdot \sin\theta$$

EXAMPLE

Find the components of force.

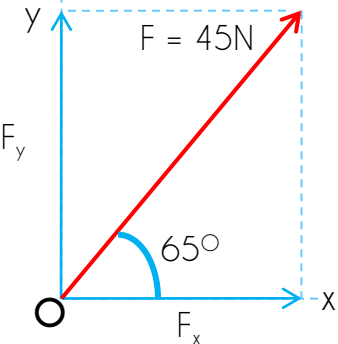
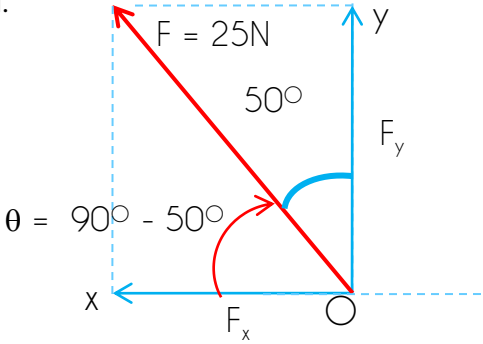
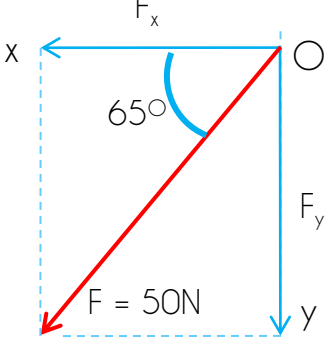
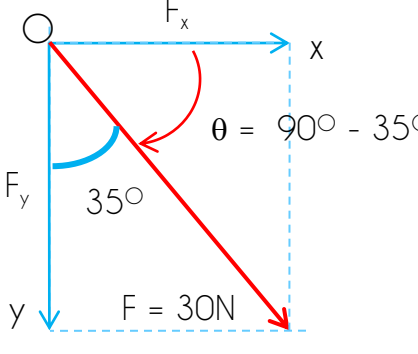
| | |
|--|---|
| i.  | Horizontal component $F_x = F \cdot \cos\theta$ $= (45) \times \cos 65$ $= 19.02 \text{ N}$ Vertical component $F_y = F \cdot \sin\theta$ $= (45) \times \sin 65$ $= 40.78 \text{ N}$ |
| ii.  | Horizontal component $-F_x = F \cdot \cos\theta$ $= -(25) \times \cos (90 - 50)$ $= -19.2 \text{ N}$ Vertical component $F_y = F \cdot \sin\theta$ $= (25) \times \sin (90 - 50)$ $= 16.06 \text{ N}$ |
| iii.  | Horizontal component $-F_x = F \cdot \cos\theta$ $= -(50) \times \cos (65)$ $= -21.1 \text{ N}$ Vertical component $-F_y = F \cdot \sin\theta$ $= -(50) \times \sin (65)$ $= -45.3 \text{ N}$ |
| iv.  | Horizontal component $F_x = F \cdot \cos\theta$ $= (30) \times \cos (90 - 35)$ $= 17.21 \text{ N}$ Vertical component $-F_y = F \cdot \sin\theta$ $= -(30) \times \sin (90 - 35)$ $= -24.57 \text{ N}$ |



PRACTICE QUESTIONS

Find the components of force.

i.

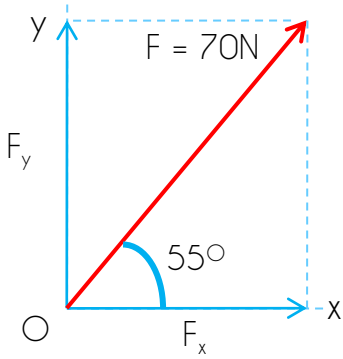

Answer: $F_x = 40.15\text{N}$
 $F_y = 57.34\text{N}$

ii.

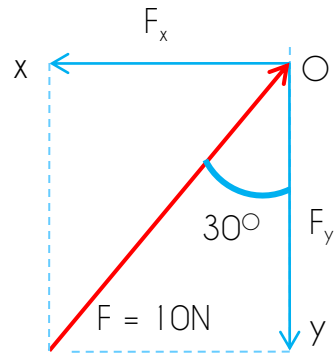

Answer: $F_x = 5\text{N}$
 $F_y = 8.66\text{N}$

iii.

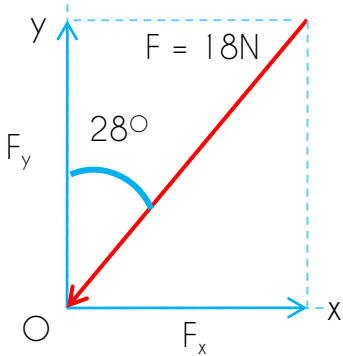

Answer: $F_x = - 8.45\text{N}$
 $F_y = -15.89\text{N}$

iv.

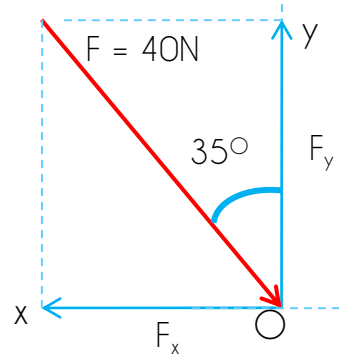

Answer: $F_x = 22.94\text{N}$
 $F_y = 32.77\text{N}$

3.1.8 Apply the concept of force in solving problems related to equilibrium of forces

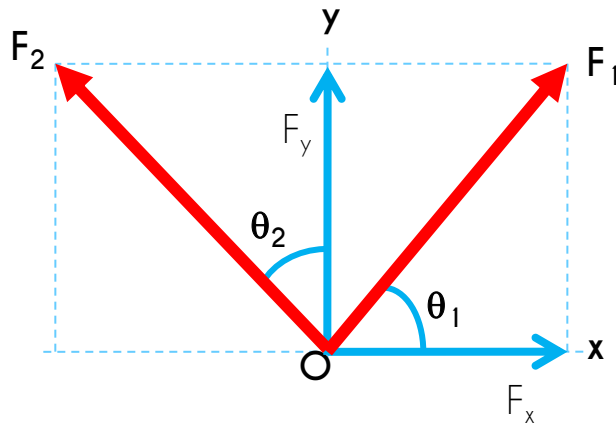

Resultant force is a single force that represents the combination of two or more force by taking into account both magnitude and direction of each particular forces.

F_{x1} = Horizontal vector component 1

F_{x2} = Horizontal vector component 2

F_{y1} = Vertical vector component 1

F_{y2} = Vertical vector component 2

F_1 = Resultant Force for component 1

F_2 = Resultant Force for component 2

F_R is the symbol representing the resultant force.

To find the resultant force and the direction,

| | |
|--|---|
| $F_R = \sqrt{\Sigma F_x^2 + \Sigma F_y^2}$ | $\tan \theta = \frac{\Sigma F_y}{\Sigma F_x}$ |
|--|---|

To find the angle θ

TIPS

0° is measured from x-axis (reference angle)

Important Information

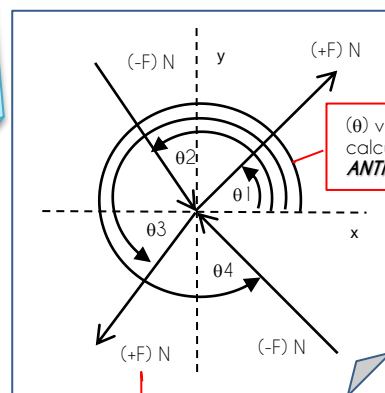

(θ) value calculated against X-axis **ANTICLOCKWISE**

Sum of F_x and F_y

TIPS

$\Sigma F_x = F_{x1} + F_{x2} + \dots + F_n$

$\Sigma F_y = F_{y1} + F_{y2} + \dots + F_n$

(F) value
Inward (\leftarrow): -ve
Outward (\rightarrow): +ve



EXAMPLE 1

Find the magnitude and direction of the resultant force.

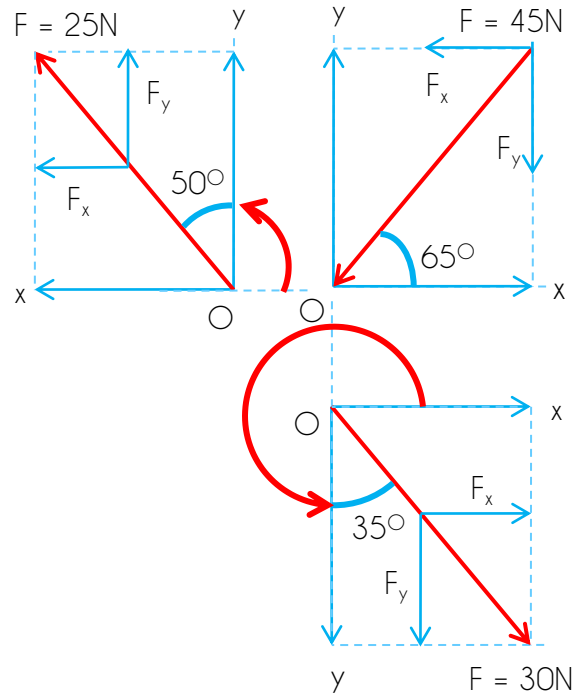
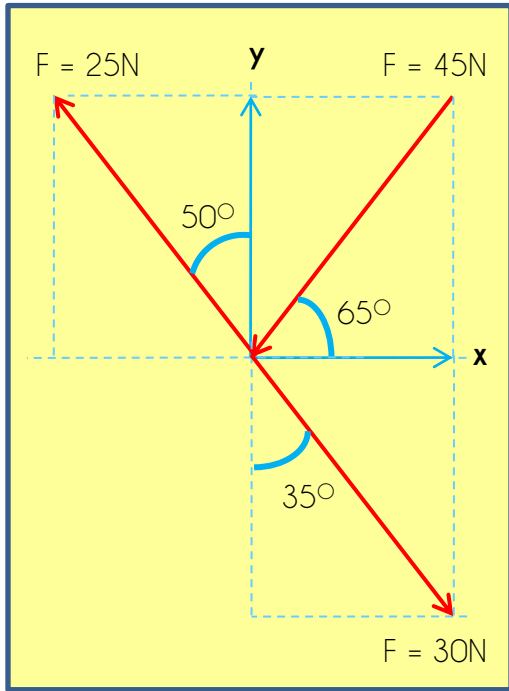

Answer :

| F | θ | $F_x = F \cdot \cos \theta$ | $F_y = F \cdot \sin \theta$ |
|------|------------------|-----------------------------|-----------------------------|
| - 45 | 65 | -19.02N | -40.78N |
| 25 | $50 + 90 = 140$ | -19.15N | 16.07N |
| 30 | $270 + 35 = 305$ | 17.21N | -24.57N |
| | | $\Sigma F_x = -20.96N$ | $\Sigma F_y = -49.28N$ |

$$F_R = \sqrt{(-20.96)^2 + (-49.28)^2}$$

$$= 53.55 \text{ N}$$

$$\theta = \tan^{-1} \frac{(-49.28)}{(-20.96)}$$

$$= 66.96^\circ$$



EXAMPLE 2

Find the magnitude and direction of the resultant force.

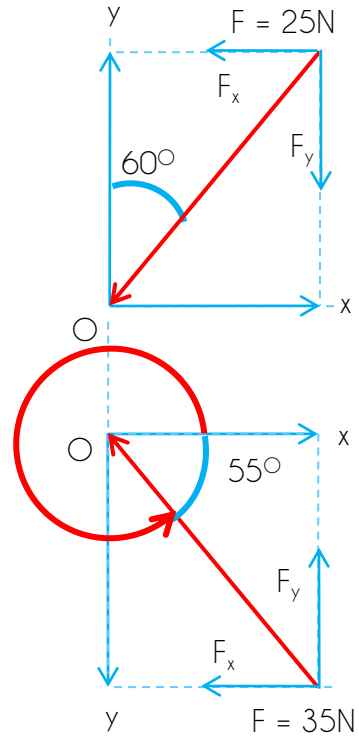
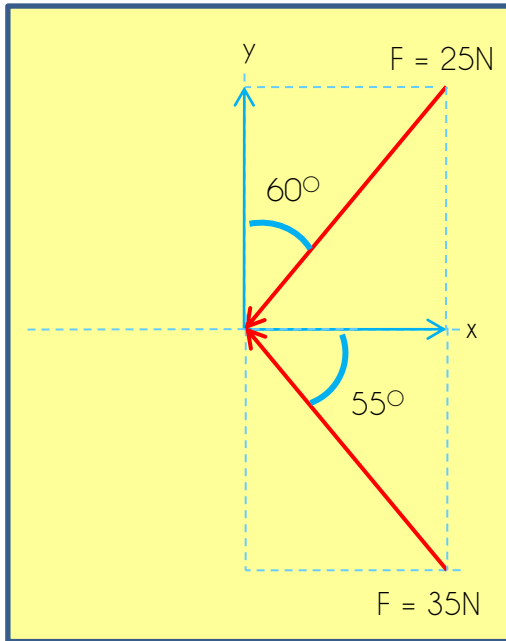

Answer :

| F | θ | $F_x = F \cdot \cos \theta$ | $F_y = F \cdot \sin \theta$ |
|------|------------------|--------------------------------|------------------------------|
| - 25 | $90 - 60 = 30$ | -21.65N | -12.5N |
| - 35 | $360 - 55 = 305$ | -20.08N | 28.67N |
| | | $\Sigma F_x = - 41.73\text{N}$ | $\Sigma F_y = 16.17\text{N}$ |

$$F_R = \sqrt{(-41.73)^2 + (16.17)^2}$$

$$= 44.75 \text{ N}$$

$$\theta = \tan^{-1} \frac{(16.17)}{(-41.73)}$$

$$= -21.18^\circ$$



EXAMPLE 3

Find the magnitude and direction of the resultant force.

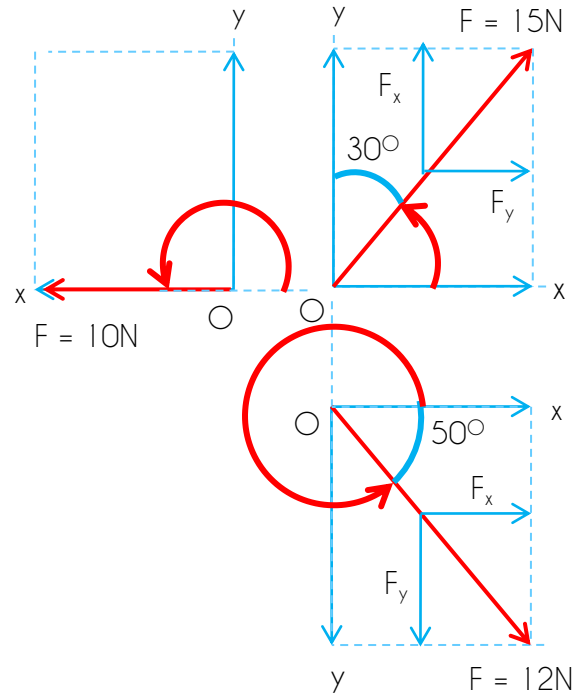
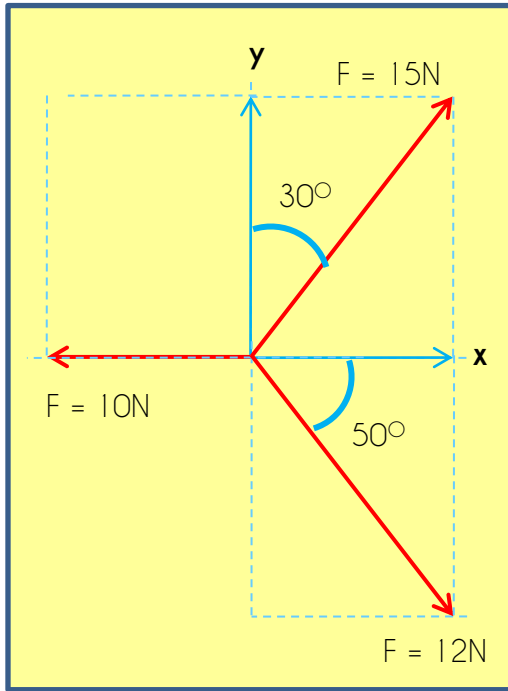

Answer :

| F | θ | $F_x = F \cdot \cos \theta$ | $F_y = F \cdot \sin \theta$ |
|----|------------------|-----------------------------|-----------------------------|
| 15 | $90 - 30 = 60$ | 7.5N | 12.99N |
| 10 | 180 | -10N | 0 |
| 12 | $360 - 50 = 310$ | 7.71N | -9.19N |
| | | $\Sigma F_x = 5.21\text{N}$ | $\Sigma F_y = 3.8\text{N}$ |

$$F_R = \sqrt{(5.21)^2 + (3.8)^2}$$
$$= 6.45\text{N}$$

$$\theta = \tan^{-1} \frac{(3.8)}{(5.21)}$$
$$= 36.12^\circ$$



PRACTICE QUESTION 1

Find the magnitude and direction of the resultant force.

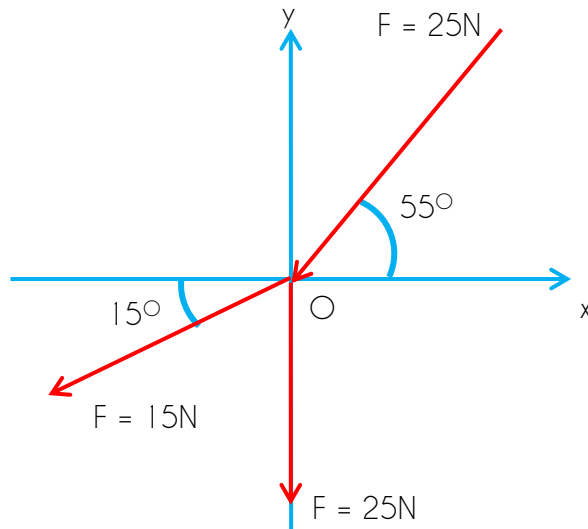

Answer: $F_R = 57.16\text{ N}$
 $\theta = 59.71^\circ$



PRACTICE QUESTION 2

Determine the resultant force and its direction.

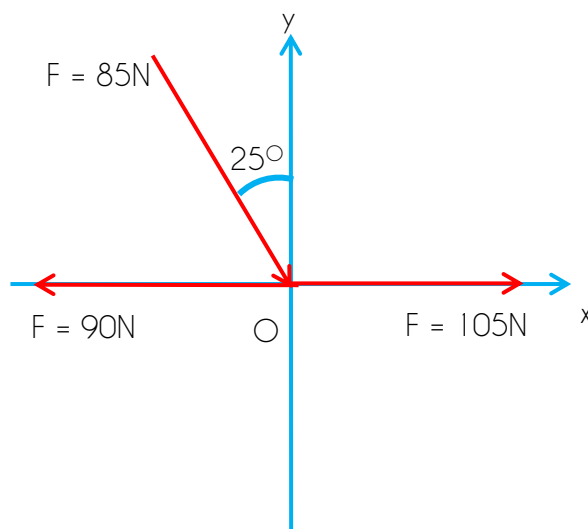

Answer: $F_R = 92.35\text{ N}$
 $\theta = -56.54^\circ$

3.2 Apply the concept of moment of force

3.2.1 Define moment of force and its unit

MOMENT

- a turning effect produced by a force acting at a distance on an object
- can be expressed as the product of the force and the distance from its line of action to a given point.

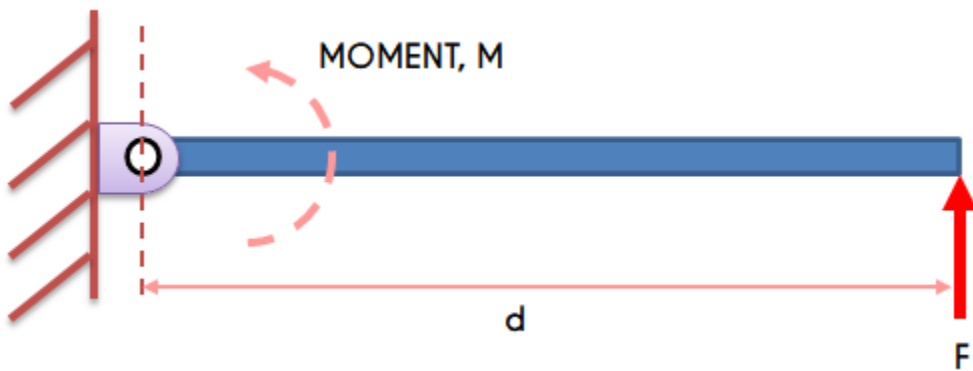

The magnitude of a moment can be calculated using the equation:

$$M(\text{Moment}) = F(\text{Force}) \times d(\text{distance})$$

This is when:

- moment (M) is measured in **Newton-metres (Nm)**
- force (F) is measured in **Newtons (N)**
- distance (d) is measured in **metres (m)**

NOTE

It is important to remember that the distance (d) is the perpendicular distance from the pivot to the line of action of the force

EXAMPLE 1

Calculate the moment acting on the pivot.

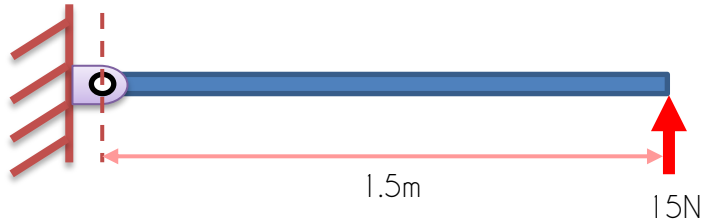

Answer:

The force acting on the beam causing the moment COUNTER-CLOCKWISE:

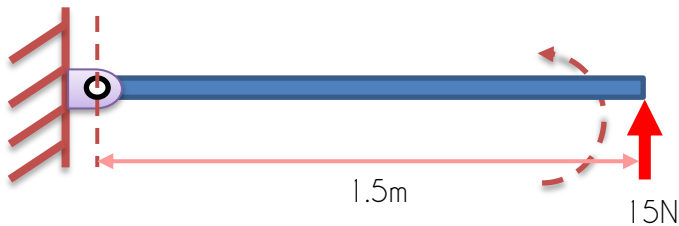

$$F = 15\text{N}$$

$$d = 1.5\text{m}$$

$$\text{Moment, } M = F \times d$$

$$= 15 \times 1.5 = \mathbf{22.5\text{Nm}} \text{ COUNTER-CLOCKWISE}$$

EXAMPLE 2

Calculate the moment acting on the pivot.

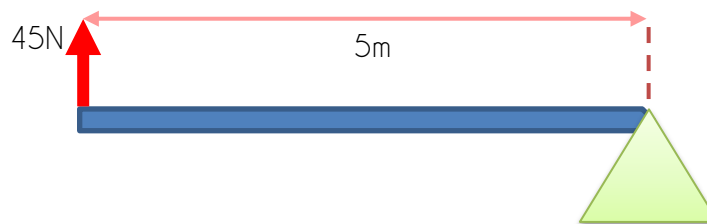

Answer:

The force acting on the beam causing the moment CLOCKWISE:

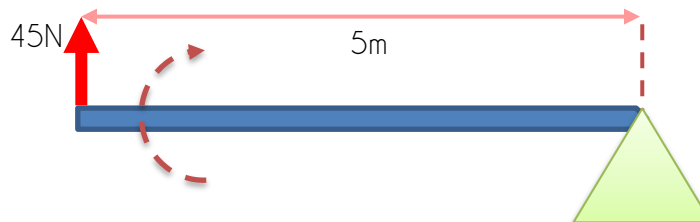

$$F = 45\text{N}$$

$$d = 5\text{m}$$

$$\text{Moment, } M = F \times d$$

$$= 45 \times 5 = \mathbf{225\text{Nm}} \text{ CLOCKWISE}$$



EXAMPLE 3

Calculate the moment acting on the pivot.

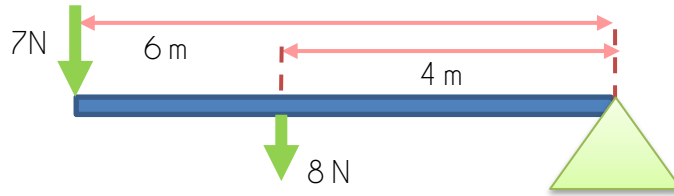

Answer:

The overall force acting on the beam causing the moment COUNTER-CLOCKWISE:

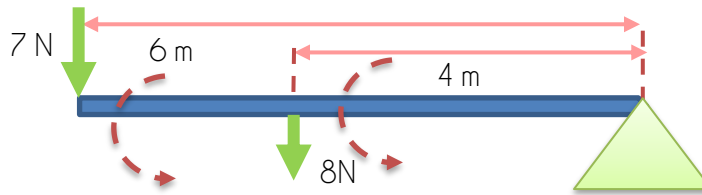

$$\begin{aligned} \text{Moment, } M &= (F_1 \times d_1) + (F_2 \times d_2) \\ &= (7 \times 6) + (8 \times 4) = \mathbf{74Nm \text{ COUNTERCLOCKWISE}} \end{aligned}$$



EXAMPLE 4

Calculate the moment acting on the pivot.

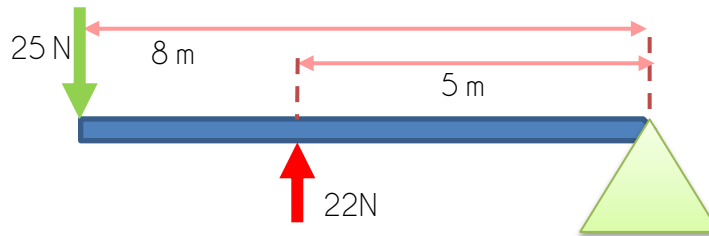

Answer:

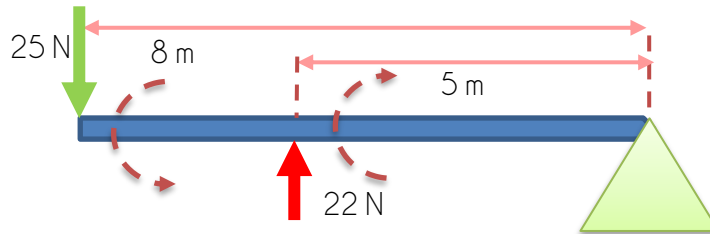

$$\begin{aligned} \text{Moment, } M &= (F_1 \times d_1) + (F_2 \times d_2) \\ \text{Moment, } M &= M_{\text{CCW}} + M_{\text{CW}} \\ &= 25 \times 8 - 22 \times 5 = \mathbf{90 Nm} \end{aligned}$$

3.2.2 Describe principle of moment of force

MOMENT OF FORCE is a measure of its tendency to cause a body to rotate about a specific point or pivot.

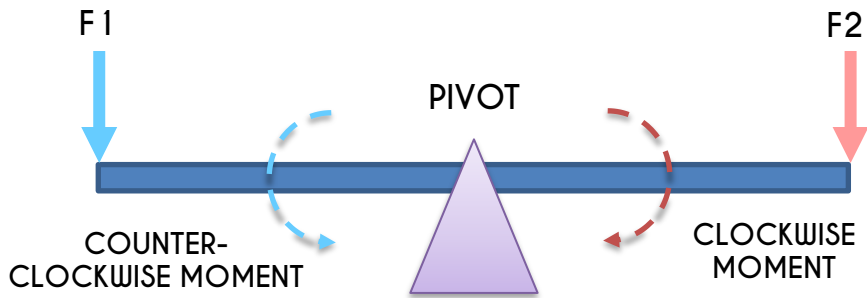

| COUNTER-CLOCKWISE MOMENT | CLOCKWISE MOMENT |
|---|--|
| <p>The diagram shows a horizontal green bar on a brown triangular pivot. A blue arrow labeled 'F (downward)' is on the left. A red double-headed arrow labeled 'distance' extends from the force to a vertical dashed line through the pivot. Below, the bar is shown tilted upwards to the right, with a blue curved arrow labeled 'M (moment)' indicating counter-clockwise rotation. A second diagram shows the bar tilted further upwards, with another blue curved arrow labeled 'M (moment)'.</p> | <p>The diagram shows a horizontal green bar on a brown triangular pivot. A red arrow labeled 'F (upward)' is on the left. A red double-headed arrow labeled 'distance' extends from the force to a vertical dashed line through the pivot. Below, the bar is shown tilted downwards to the right, with a red curved arrow labeled 'M (moment)' indicating clockwise rotation. A second diagram shows the bar tilted further downwards, with another red curved arrow labeled 'M (moment)'.</p> |

PRINCIPLE MOMENT OF FORCE states that the moment of any force is equal to the sum of the moments of the components of that force

$$\text{Total applied force, } F \uparrow \text{ (upward force)} = \text{Total reaction force, } F \downarrow \text{ (downward force)}$$

Furthermore, if a body is in equilibrium, the sum of the clockwise moments is equal to the sum of the anticlockwise moments

$$\text{Sum of moment counter-clockwise, } M_{CCW} = \text{Sum of moment clockwise, } M_{CW}$$

NOTE

The principle of moment of force is used to solve :

- Determining the centre of gravity
- Finding the reaction force
- Determining the distance of the reaction force

3.2.3 Apply the concept and formula of moment of force in solving the related problem

There are **TWO (2)** methods of solving problems:

1. Moment of force (Force moment)
2. Resultant moment of force

Moment of force (Force moment)

For an object to be in equilibrium,

Sum of moment counter-clockwise, M_{CCW} = Sum of moment clockwise, M_{CW}

To solve the problems :

1. Identify the forces that will cause the clockwise and counter-clockwise moments
2. Find the clockwise and counter-clockwise moments
3. Placed any point on the beam as the pivot of the system (if it is not given)
4. Equate the clockwise and counter-clockwise moments to solve the problems

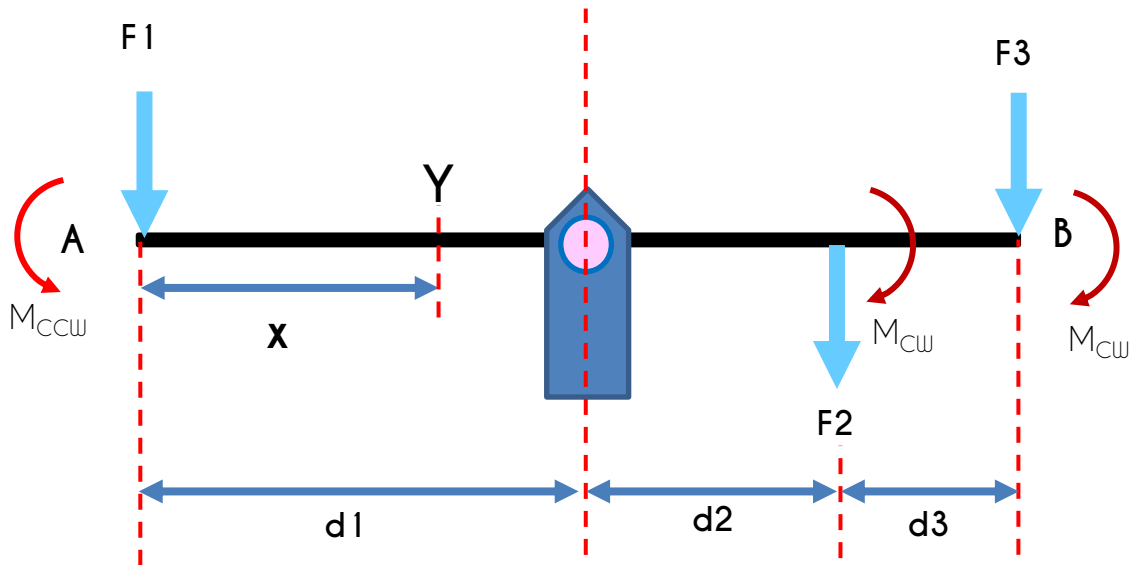

Assume the position of the centre of gravity is at Y from end A with length of x.

SUM OF MOMENT CLOCKWISE = SUM OF MOMENT COUNTER-CLOCKWISE

$$F_2((d_1 + d_2) - x) + F_3((d_1 + d_2 + d_3) - x) = (F_1)(x)$$

$$(F_2)(d_1) + (F_2)(d_2) - (F_2)(x) + (F_3)(d_1) + (F_3)(d_2) + (F_3)(d_3) - (F_3)(x) = (F_1)(x)$$

$$(F_2)(x) + (F_3)(x) + (F_1)(x) = (F_2)(d_1) + (F_2)(d_2) + (F_3)(d_1) + (F_3)(d_2) + (F_3)(d_3)$$

$$x = \frac{[(F_2)(d_1) + (F_2)(d_2) + (F_3)(d_1) + (F_3)(d_2) + (F_3)(d_3)]}{F_2 + F_3 + F_1}$$

Resultant moment of force

For an object to be in equilibrium,

Resultant moment of force = sum of moment of a force action

To solve the problems :

1. Placed any point on the beam as the centre of gravity (if it is not given) and assume any end of the beam as the pivot
2. Identify upward and downward forces applied
3. Identify the forces that will cause the clockwise and anticlockwise moments
4. Find the resultant moment of force
5. Find the sum of moment of force action
6. Equate the resultant moment of force and the sum of moment of force to solve for the centre of gravity.

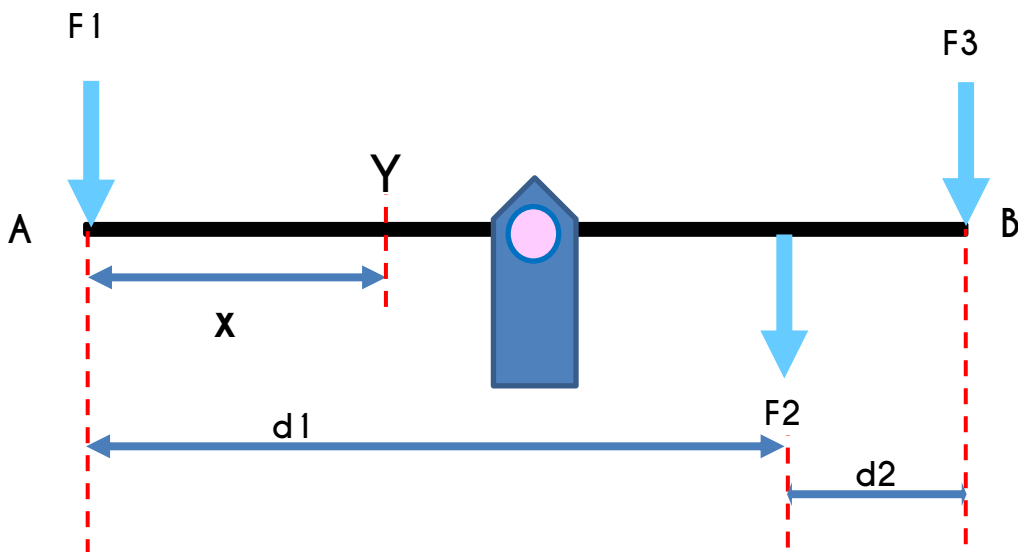

Assume the position of the centre of gravity is at Y from end A with length of x (A as the pivot).

$$\text{RESULTANT MOMENT, } M_R = (F_1 + F_2 + F_3)(x)$$

$$\text{SUM OF MOMENT OF FORCE, } \sum M = (F_1)(d_0) + (F_2)(d_0 + d_1) + F_3)(d_0 + d_1 + d_2)$$

$$\text{RESULTANT MOMENT, } M_R = \text{SUM OF MOMENT OF FORCE, } \sum M$$

$$(F_1 + F_2 + F_3)(x) = (F_1)(d_0) + (F_2)(d_0 + d_1) + F_3)(d_0 + d_1 + d_2)$$

$$x = \frac{[(F_1)(d_0) + (F_2)(d_0 + d_1) + F_3)(d_0 + d_1 + d_2)]}{(F_1 + F_2 + F_3)}$$

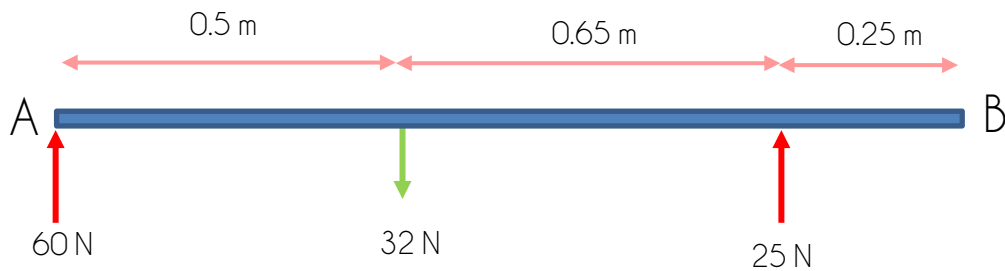

EXAMPLE 1

Find the centre of gravity of the bar, to make sure it is in equilibrium by using *moment of force*.

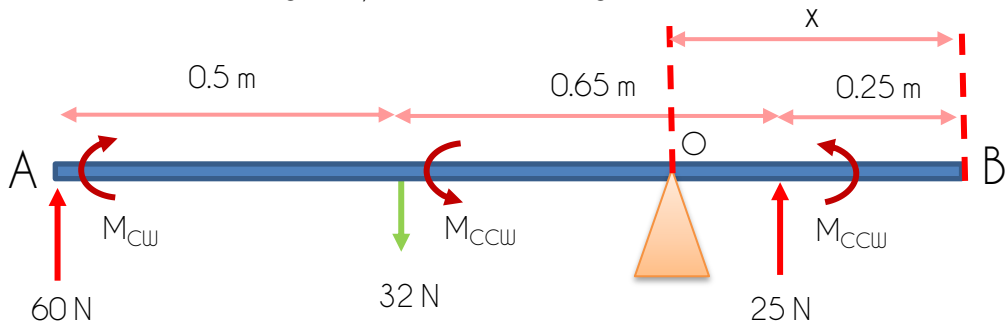

Answer:

Assume the centre of gravity is at O, with length of 'x' from B



Moment of force (Force moment)

SUM OF MOMENT CLOCKWISE = SUM OF MOMENT COUNTER-CLOCKWISE

$$60((0.5 + 0.65 + 0.25) - x) = 32((0.65 + 0.25) - x) + (25(x - 0.25))$$

$$84 - 60x = 28.8 - 32x + 25x - 6.25$$

$$32x - 60x - 25x = 28.8 - 84 - 6.25$$

$$x = \frac{-61.45}{-53} = 1.16 \text{ m from B}$$

TIPS

Centre of gravity of a beam.

If you calculate from end A, and calculate from end B. You can add both lengths from the end A and B, to get the total length of a beam.

EXAMPLE 2

Find the centre of gravity of the bar, to make sure it is in equilibrium by using *moment of force* and *resultant moment of force*.

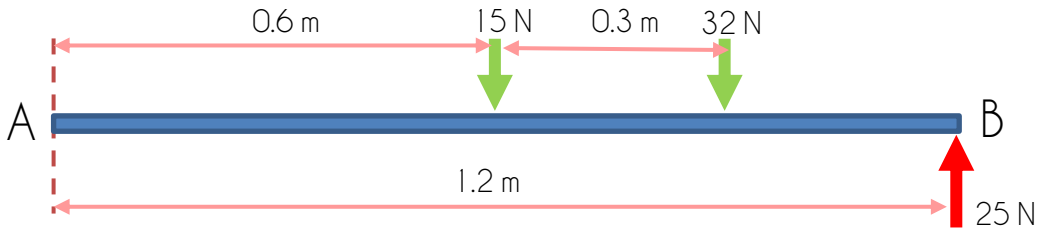

Answer:

Moment of force (Force moment)

Assume the centre of gravity is at O, with length of 'x' from A

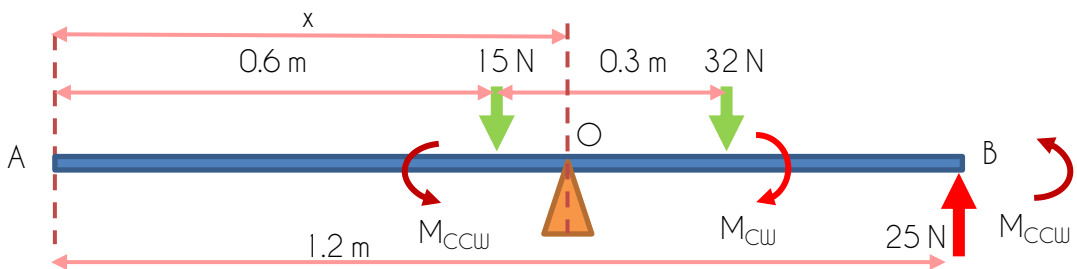

SUM OF MOMENT CLOCKWISE = SUM OF MOMENT COUNTER-CLOCKWISE

$$32((0.3 + 0.6) - x) = (15(x - 0.6)) + (25(1.2 - x))$$

$$28.8 - 32x = 15x - 9 + 30 - 25x$$

$$-32x - 15x + 25x = -28.8 - 9 + 30$$

$$x = \frac{-7.8}{-22} = 0.35 \text{ m from A}$$

Resultant moment of force

Assume the centre of gravity is at O, from A

$$\text{RESULTANT MOMENT, } M_R = (15 + 32 + (-25))(x)$$

$$\text{SUM OF MOMENT OF FORCE, } \Sigma M = (15)(0.6) + (32)(0.6 + 0.3) + (25)(1.2)$$

$$\text{RESULTANT MOMENT, } M_R = \text{SUM OF MOMENT OF FORCE, } \Sigma M$$

$$(15 + 32 + (-25))(x) = (15)(0.6) + (32)(0.6 + 0.3) + (-25)(1.2)$$

$$x = \frac{7.8}{22} = 0.35 \text{ m from A}$$

EXAMPLE 3

Find the centre of gravity of the bar, to make sure it is in equilibrium by using *moment of force* and *resultant moment of force*.

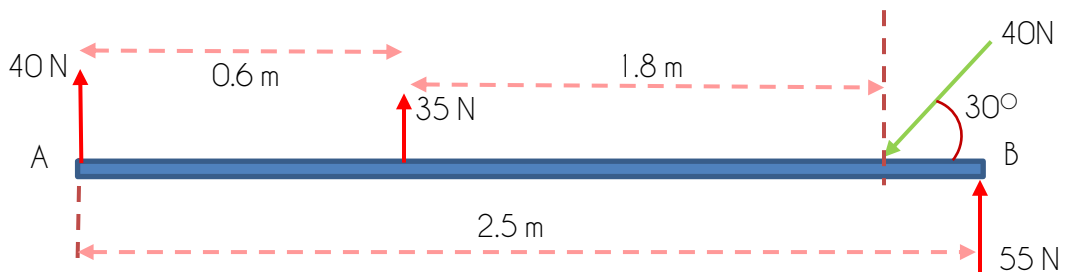

Answer:

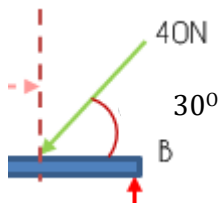

$$F_y = F \cdot \sin\theta$$

$$= (40) \cdot \sin 30^\circ = 20 \text{ N}$$

Assume the centre of gravity is at O, with length of 'x' from A

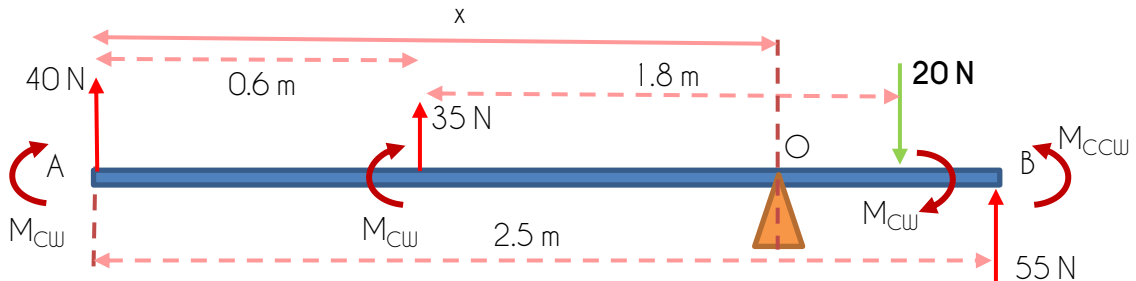

Moment of force (Force moment)

SUM OF MOMENT CLOCKWISE = SUM OF MOMENT COUNTER-CLOCKWISE

$$40(x) + 35(x - 0.6) + 20((1.8 + 0.6) - x) = 55(2.5 - x)$$

$$40(x) + 35x - 21 + 48 - 20x = 137.5 - 55x$$

$$40x + 35x - 20x + 55x = 21 + 48 + 137.5$$

$$x = \frac{110.5}{110} = 1.00 \text{ m from A}$$



Assume the centre of gravity is at O, with length of 'x' from A

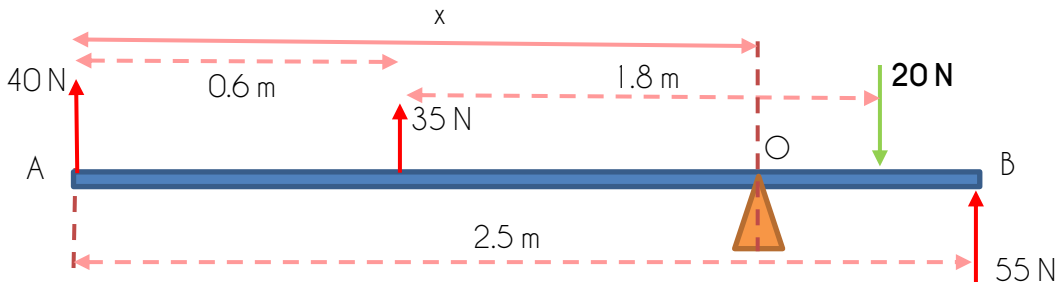

Resultant moment of force

$$\text{RESULTANT MOMENT, } M_R = (-40 + 35 + (-20) + 55)(x)$$

$$\text{SUM OF MOMENT OF FORCE, } \Sigma M = (40)(0) + (35)(0.6) + (-20)(1.8 + 0.6) + (55)(2.5)$$

$$\text{RESULTANT MOMENT, } M_R = \text{SUM OF MOMENT OF FORCE, } \Sigma M$$

$$(40 + 35 + (-20) + 55)(x) = (40)(0) + (35)(0.6) + (-20)(1.8 + 0.6) + (55)(2.5)$$

$$x = \frac{110.5}{110} = 1.00 \text{ m from A}$$



EXAMPLE 4

Given the length of the beam is 13 m. Calculate the reaction forces in both of the supporter.

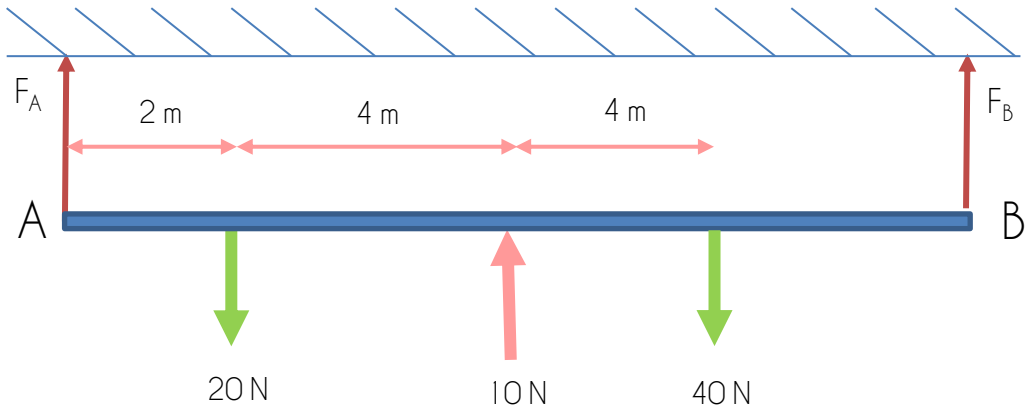

Answer:

From the Principle Moment of force, $\sum F(\text{upward}) \uparrow = \sum F(\text{downward}) \downarrow$

$$F_A + F_B + 10 = 20 + 40$$

$$F_A + F_B = 20 + 40 - 10 = 50 \text{ N}$$

Let one of the supporters as the pivot, for example point F_A at A.

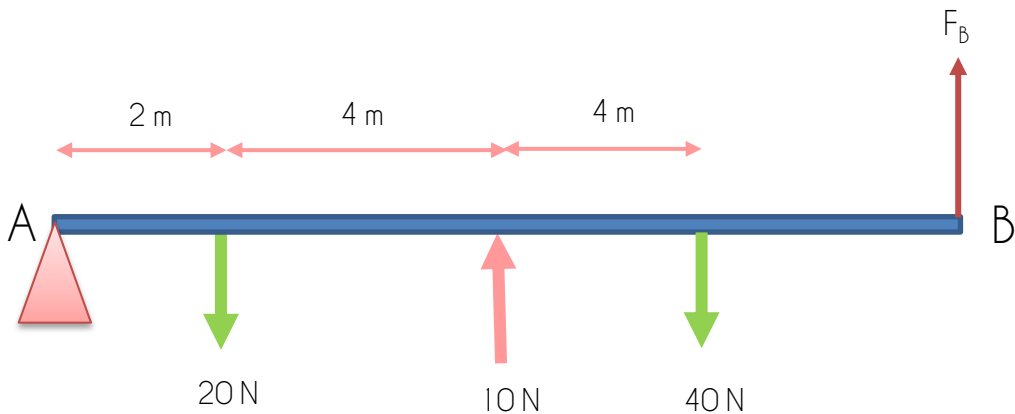

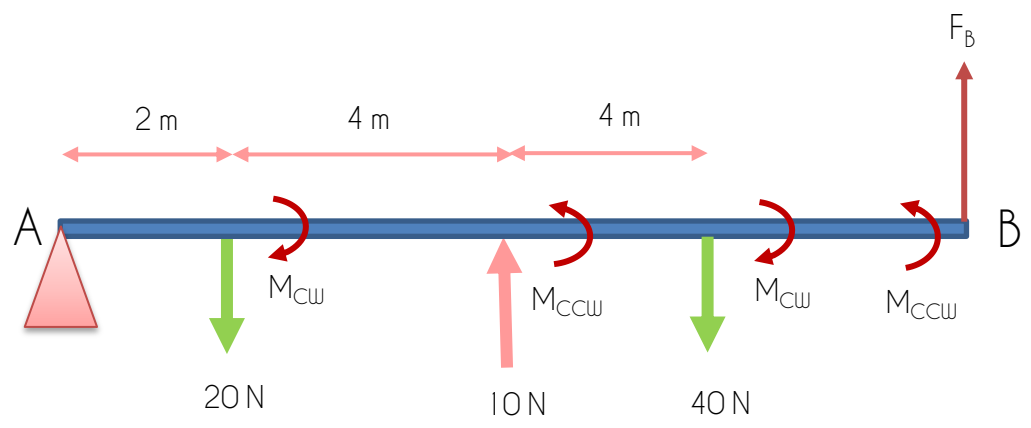

SUM OF MOMENT CLOCKWISE = SUM OF MOMENT COUNTER-CLOCKWISE

$$20(2) + 40(4 + 4 + 2) = 10(4 + 2) + F_B(13)$$

$$F_B = \frac{380}{13} = 29.23 \text{ N}$$

Answer:

From the Principle Moment of force, $\sum F(\text{upward}) \uparrow = \sum F(\text{downward}) \downarrow$

$$F_A + F_B = 50 \text{ N}$$

Let $F_B = 29.23 \text{ N}$

$$F_A + 29.23 = 50 \text{ N}$$

$$F_A = 50 - 29.23 = 20.77 \text{ N}$$

$$F_A = 20.77 \text{ N}$$

$$F_B = 29.23 \text{ N}$$



PRACTICE QUESTION 1

Find the centre of gravity from end B, by assuming the bar is in equilibrium state by using *moment of force* and *resultant moment of force*.

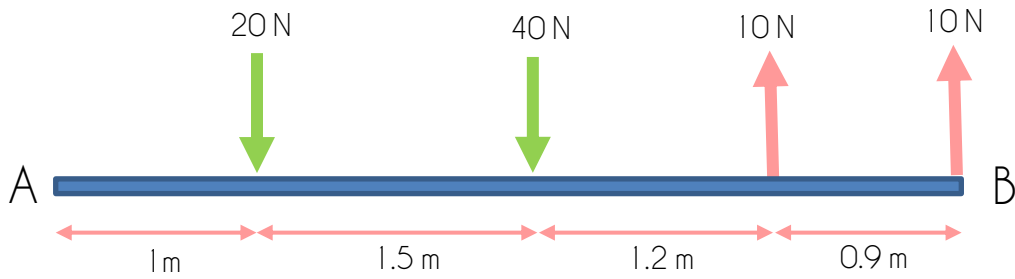

Answer: $x = 0.925 \text{ m}$ from left



PRACTICE QUESTION 2

Find the centre of gravity of the bar, to make sure it is in equilibrium by using *moment of force* and *resultant moment of force*. Given the total length of the bar is 8.5 m.

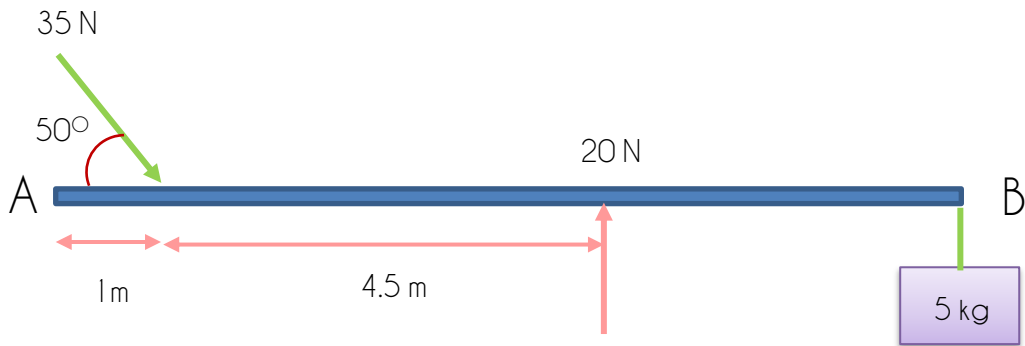

Answer: $x = 6.39 \text{ m}$ from left



PRACTICE QUESTION 3

Calculate the centre of gravity, 'x', so that the beam is in equilibrium by using *moment of force* method.

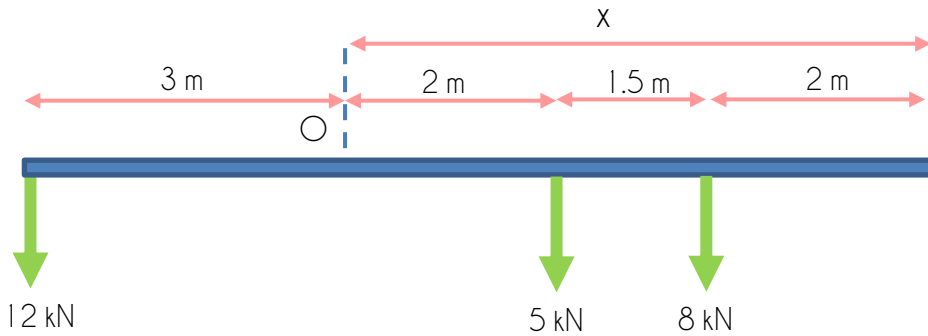

Answer: $x = 5.42 \text{ m}$



PRACTICE QUESTION 4

Find the value of force at point A and B for the beam, if the system is in equilibrium.

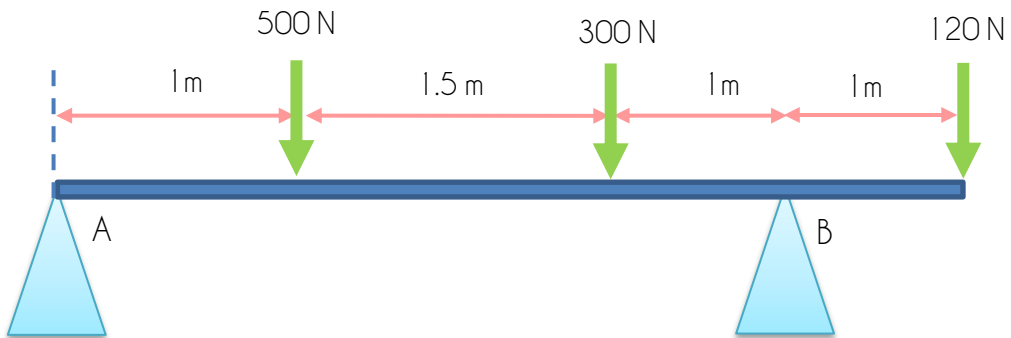

Answer: $F_A = 408.57 \text{ N}$
 $F_B = 511.43 \text{ N}$

Reference

- 1-D Kinematics: Describing the Motion of Objects. (n.d.). <https://www.physicsclassroom.com>. Retrieved 2021, from <https://www.physicsclassroom.com/Physics-Tutorial/1-D-Kinematics>
- Azizul Izham Abdul Rahim, Fara Nur Asma Mohd Basri, Nur Maisarah Abdullah, Shamsul Mazalan, Siti Morni Ab Rahman, Zamzarina Daud@Bukhari (2018). *Engineering Science For Polytechnic*. Politeknik Port Dickson.
- Caroline L. (n.d.). What is moment and how do you calculate it? <http://blog.cambridgecoaching.com>. Retrieved 2021, from <http://blog.cambridgecoaching.com/physics-tutor-what-is-moment-and-how-do-you-calculate-it>
- Electrical Force. (2021, March 22). <https://byjus.com>. <https://byjus.com/physics/electrical-force/>
- Equations of motion. (n.d.). <https://isaacphysics.org>. Retrieved 2021, from https://isaacphysics.org/concepts/cp_eq_of_motion
- Free High School Science Texts (FHSST) Authors. (2008). *The Free High School Science Texts: Textbooks for High School Students Studying the Sciences Physics Grades 10 - 12*. [www.fhsst.org](http://ftp.igh.cnrs.fr/pub/nongnu/fhsst/Physics_Grade_10-12.pdf). http://ftp.igh.cnrs.fr/pub/nongnu/fhsst/Physics_Grade_10-12.pdf
- Freefall review (article). (n.d.). Khan Academy. Retrieved 2021, from <https://www.khanacademy.org/science/high-school-physics/one-dimensional-motion-2/objects-in-freefall/a/freefall-ap1>
- Geno, H. (2018, August 29). CHAPTER 3. <https://fliphtml5.com>. <https://fliphtml5.com/iasw/sdsu/basic>
- Luebkeman, C. H., & Peting, D. (1995). What is a Moment? <https://web.mit.edu>. https://web.mit.edu/4.441/1_lectures/1_lecture5/1_lecture5.html
- Magnetic Force | Definition, Formula, Examples, & Facts. (n.d.). Encyclopedia Britannica. Retrieved 2021, from <https://www.britannica.com/science/magnetic-force>
- Meenng. (2007, September 17). Turning Effect of Forces. Slideshare. <https://www.slideshare.net/meenng/turning-effect-of-forces>

Reference

More, H. (2019, October 22). Forces: The concept, their definition, types, characteristics, effects. The Fact Factor.

https://thefactfactor.com/facts/pure_science/physics/forces/4200/

Muniandy, L. (n.d.). NOTES FOR ENGINEERING SCIENCE (SEM 1). Scribd. Retrieved 2021, from <https://www.scribd.com/document/194373321/NOTES-FOR-ENGINEERING-SCIENCE-SEM-1>

Nave, R. (2000). Mass, Weight, Density. <https://Ef.Engr.Utk.Edu>.

<https://ef.engr.utk.edu/hyperphysics/hbase/mass.html>

Nelson, J. (n.d.). Moments - Moments, levers and gears - AQA - GCSE Physics (Single Science) Revision - AQA. BBC Bitesize. Retrieved 2021, from

<https://www.bbc.co.uk/bitesize/guides/ztjpb82/revision/1>

Oxford University Press (OUP). (n.d.). Moment. Lexico.Com. Retrieved 2021, from

<https://www.lexico.com/definition/moment>

Rick Turner. (2010, October 10). Balanced and Unbalanced Forces. Slideshare.

<https://www.slideshare.net/rickaturner/balanced-and-unbalanced-forces-5408256>

SI Units. (2021, February 8). NIST. <https://www.nist.gov/pml/weights-and-measures/metric-si/si-units#:~:text=The%20International%20System%20of%20Units,globe%20as%20World%20Metrology%20Day%20>.

Termimi Hidayat Mahyan, Mohd Izwan Shaharuddin, Noorain Ithnin, Yap Tek Chuan, Falinah Misol, Nursahizalina Mohd Sa'at, & Matieu Ah Kim (2017). *Engineering Science Polytechnic Edition*. Politeknik Kuching Sarawak.

Types of Forces. (n.d.). The Physics Classroom. Retrieved 2021, from

<https://www.physicsclassroom.com/class/newtlaws/Lesson-2/Types-of-Forces>

What are the kinematic formulas? (article). (n.d.). Khan Academy. Retrieved 2021, from

<https://www.khanacademy.org/science/physics/one-dimensional-motion/kinematic-formulas/a/what-are-the-kinematic-formulas>

Reference

What is buoyant force? (article) | Fluids. (n.d.). Khan Academy. Retrieved 2021, from <https://www.khanacademy.org/science/physics/fluids/buoyant-force-and-archimedes-principle/a/buoyant-force-and-archimedes-principle-article>

What is normal force? (article). (n.d.). Khan Academy. Retrieved 2021, from <https://www.khanacademy.org/science/physics/forces-newtons-laws/normal-contact-force/a/what-is-normal-force>

e ISBN 978-967-2897-11-8



9 7 8 9 6 7 2 8 9 7 1 1 8