

FOR ELECTRICAL ENGINEERING



# AC MOTOR CONTROL

Volume 1

RAHAYU BINTI JONIT

© CETAKAN 2024



# AC MOTOR CONTROL Volume 1 (Chapter 1-6)

Chapter 1-6 : Rahayu Binti Jonit

Published By :  
Ministry of Higher Education  
Electrical Engineering Department,  
Politeknik Port Dickson,  
<https://www.polipd.edu.my>

MOTOR CONTROL Volume1 (Chapter 1 – 3)/RAHAYU BINTI JONIT  
Mode of access : Internet



Cataloguing-in-Publication Data

Perpustakaan Negara Malaysia

A catalogue record for this book is available  
from the National Library of Malaysia

eISBN 978-629-7643-63-2

Published by:  
Politeknik Port Dickson  
KM14, Jalan Pantai 71050, Si Rusa,  
Port Dickson, Negeri Sembilan.

**COPYRITE** Each part of this publication may not be reproduced  
or distributed in any forms by any means or retrieval system  
without pripi written permission,

# ACKNOWLEDGEMENT

## PATRON

HJ. HASAN BIN MOHD SHARIF  
Director, Politeknik Port Dickson

## ADVISORS

Abdul Rahim bin Ibrahim  
Deputy Director (Academic), Politeknik Port Dickson  
Abdul Razak bin Ismail  
Head of Electrical Department, Politeknik Port Dickson

## EDITORS

xxxx  
Electrical Department, Politeknik Port Dickson

## FACILITATORS

Xxxxx

## WRITERS

Chapter 1-6 : Rahayu binti Jonit

## GRAPHIC DESIGNER

Rahayu Binti Jonit

We would like to convey our utmost gratitude to the Department of Polytechnic and Community Collage Education particularly the E-learning and Instructional Division (BIPD) for funding our e-book project.

We hereby declare that this module is our original work. To the best of our knowledge it contains no materials previously written or published by another person. However, if there is any, due acknowledgement and credit are mentioned accordingly in the e-book.

# PREFACE

The e-book AC Motor Control suitable with real situation in study of electrical, mechanical engineering. The content of this e-book volume 1.0 consist seven chapter are Introduction Motor Control, Component AC Motor Control, Types of Stator, Direct Online Starter, Star Delta starter, Auto Transformer starter and Rotor Resistance starter. Very topic covers a whole range of topic learned by the students and is published based on the curriculum for Course of Industrial Management issued by the Curriculum Division, Department of Polytechnic Education (DPE), ministry of Higher Education of Malaysia.

Student will learn about introduces and approach with minimum theory of the type of component motor control. fundamentals of motor control construction, Types of motor control or stator and sketch the main circuit and the control circuit. The content also covers how to choose the type of motor control based on the load to be used.

# CONTENT

Topic  
1

Introduction Motor  
Control

Page  
7

Topic  
2

Component AC Motor  
Control

Page  
16

Topic  
3

Types of Motor  
Control/Stator

Page  
37

Topic  
4

Direct Online Starter

Page  
43

Topic  
5

Star Delta starter

Page  
54

Topic  
6

Auto Transformer starter

Page  
63

Topic  
7

Rotor Resistance starter

Page  
73

TOPIC 1:  
INTRODUCTION  
MOTOR  
CONTROL



# INTRODUCTION MOTOR CONTROL



Figure 1: Motor control

The controller is a hardware switch that acts as a control switch to start and stop the motor. Controls are operated with certain characteristics according to the requirements of current electricity regulations (example: Electricity Supply Act 1990 And Electricity Regulations 1994, IEE Regulations 16th Edition and so on).

An induction motor, when switched directly to the supply will take a current amounting to between five and seven times the full load current while the torque produced is only about twice that. For motors with large rated capacity, direct switching must be avoided because the resulting high starting current will interfere with the operation of other electrical equipment connected to the same supply line. However, for small motors direct switching is allowed.

BS4941 Part I 1979 defines a starter as a combination of switching means for starting and stopping a motor complete with a suitable overload protection device. The main purpose of the starter is to reduce the starting current of the motor, complete with protection and safety control features.



## IEE Regulations For Motors

### **476-7**

Each motor must provide a isolation switch to decide on the supply to the motor, to the motor starter, to the control circuit and so on. It should be placed in a convenient place.

### **473-2**

protection device can be connected to any circuit along the motor end of the motor with. Condition no branch. It can be installed in beginners.

### **473-6**

short circuit protection should be installed in the event of a decrease in current carrying capacity on the distribution board and in the load section in terms of the distance between the short circuit protection device and the starting point carrying capacity not exceeding 3 meters.

### **552-1**

the rated cable current used to carry the starting current, current acceleration and load current motor at least equal to the full load current motor.

### **552-3**

motors over 0.37 kW should have a control over current (overload) to protect the motor and cable between the control and the motor.



## Definition of Motor Control

Starters commonly used in daily tasks:

i. Manual starter

The manual starter closing the main contact is made with manual energy

ii. Electromagnetic starter (automatic)

The electromagnetic starter closes the main contact using an electromagnetic force. This feature is for automatic operation.

Stater or Control contains several control and protection components and acts in an integrated manner to control and protect the motor according to the required task and function. First able to control:-

- Reverse rotation
- Motor speed
- Protect the motor from overload
- Short circuit
- Provision of motors (such as electric cranes)

### The main purpose of Stater is to

- reduce the starting current of the motor.
- Avoid the danger of the motor starting suddenly.
- For remote control operation
- The motor can be started in stages

### The Purpose Of Life Is Used

In order to turn on a motor, a starting control method called a Motor Starter must be held, for:-

- Protects the motor from the danger of current when it is started.
- Protect the motor from the danger of overload.
- Can prevent the motor from starting on its own after a power outage is reconnected

### Starters commonly used in daily tasks:

- Manual starter
  - The manual starter closing the main contact is made with manual energy
  - self-control the "switch" whether a circuit needs to be turned on or off.
  - This control requires special observation for changes in this system.
- semi-automatic control
  - Using a magnetic starter and one or more manual controls such as push buttons, toggle switches or spindle switches.
  - This system is called semi-automatic control because all the driving tools are operated manually while the motor starter uses a magnetic type.
  - This system is also a form of protection control without no voltage or undervoltage protection.
  - The starter will stop when a voltage failure occurs but will not restart automatically when the voltage flow returns.
- Electromagnetic starter (automatic)
  - work automatically without the need for manual assistance. This control does not require our direct observation unless it is damaged.
  - The electromagnetic starter closes the main contact using an electromagnetic force. This feature is for automatic operation
  - A system involving a magnetic starter or contact whose operation is controlled by one or more automatic drives. Functions as a no-voltage release control or low-voltage protector also called a two-wire control. The starter will stop when a voltage failure occurs and work again as soon as the voltage flow is resumed.





## Conditions for Electric motor control (DC/AC)

### i. ON the motor (stator)

For large motors(>0.5hp) switched on directly from the supply is extremely dangerous because the current is high, so a starter is required. Induction motors when driven directly to the supply take five to seven times the full load current.

Is the process of giving power to a motor so that the motor operates. It can be done electrically by controlling the starter current so that the motor speed is proportional.

### ii. Controls motor speed

Controls speed, reverse advance and circuit sequence control.

can control the movement of the motor whether speed, slow, forward reverse and so on. Additional controls are required to remotely control, such as a drive, float switch, foot switch, flow switch, switch, etc.

The control of motor speed is accomplished by controlling the current or voltage to the motor. That means controlling the power delivered to the motor. Remember that:

$$\text{power} = \text{volts} \times \text{amperes}$$

If you decrease the voltage of current, the power will also naturally decrease. A study of motor control then involves the study of methods to control power delivered to the motor.

### iii. OFF the motor

Can prevent the motor from starting on its own after a power outage is reconnected.

Able to stop the motor or disconnect the circuit manually @ automatically, avoiding short circuit current damage and overload.

Is the process of producing zero torque for a motor that is operating. It is controlled electromechanically (stopping the rotation mechanically) and electrically (giving a reverse current to the actuator so that the current can prevent the flow of the existing current)



## Motor Installation & Schematic circuit

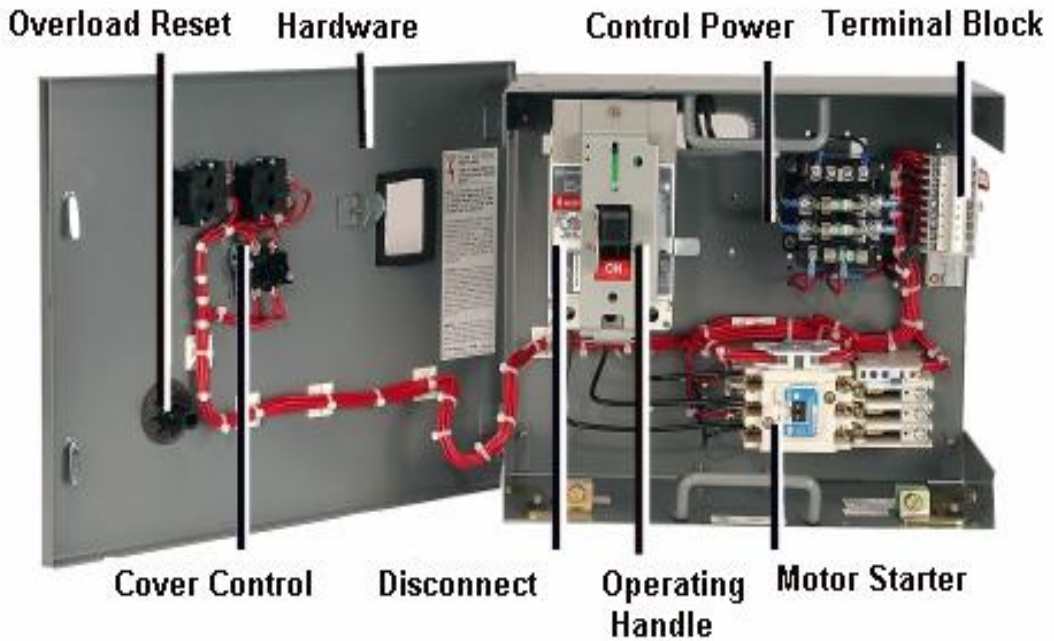

Figure 2: Motor Starter schematic diagram

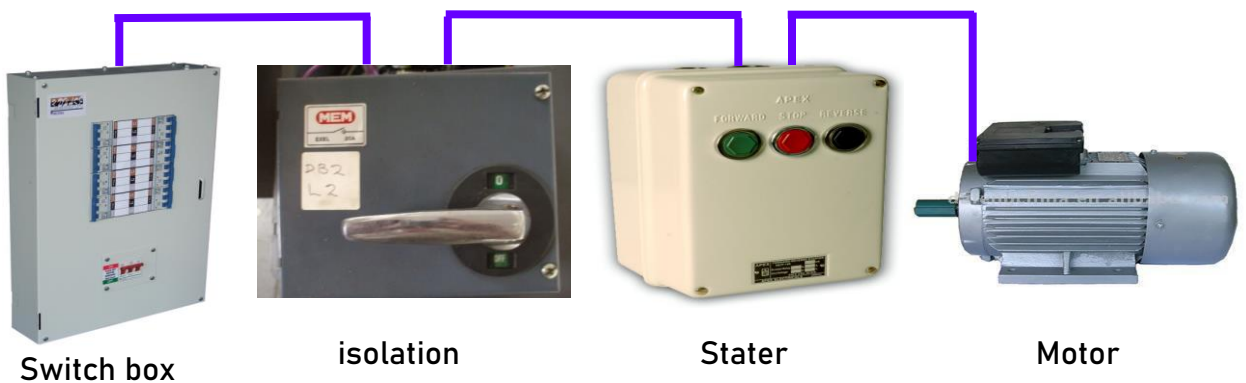

Figure 3: Motor Installation A.C More Than 0.5HP

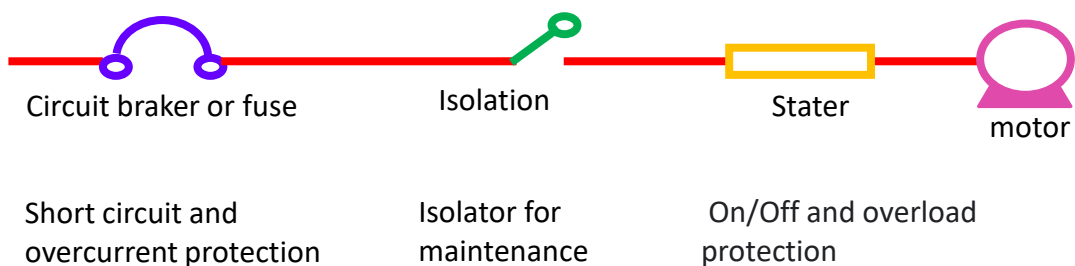

Figure 4: Schematic circuit of an electric motor installation over 0.375KW



## QUESTION 1

State **TWO (2)** IEE rules each related to the Basic motor control and Motor protection

## SOLUTION 1

Basic motor control	Motor protection
Every electric motor must have a control device for turning the motor on and off that is installed in a place that is easily operated by the person using the motor	The cable current rating of the motor circuit must be at least equal to the full load current rating of the motor.
Can prevent the motor from starting automatically after being stopped or after receiving a voltage failure except for use that can cause danger if it does not start automatically. If this is required appropriate control equipment must be in place	The fuse rating that controls the motor circuit must not exceed the circuit cable rating.
When there is more than one method of turning off the motor, should be held a way so that the motor cannot be restarted before all the breakers are reset.	When a starter is provided with overcurrent control, the rating of the fuse or circuit breaker protecting the motor circuit can be up to twice the rating of the cable between the fuse and the starter.
An isolator must be provided to disconnect the supply to the motor. Let it be the isolator is located far from the motor, additional control equipment must be provided near the motor. If necessary, the isolator should be lockable in the OFF state.	The cable size for the motor circuit must be able to carry the starting current and full load current of the motor.
Every electric motor with a rating of more than 0.37KW must have an overcurrent control device to control the motor circuit and the current to the motor.	

Choose only 2 answer.



## QUESTION 2

Define motor control in terms of Turn ON and turn OFF

## SOLUTION 2

Turn ON	Turn OFF
<ul style="list-style-type: none"><li>• Controls speed, reverse advance and circuit sequence control.</li><li>• Is the process of giving power to a motor so that the motor operates. It can be done electrically by controlling the starter current so that the motor speed is proportional.</li></ul>	<ul style="list-style-type: none"><li>• Able to stop the motor or disconnect the circuit manually @ automatically, avoiding short circuit current damage and overload.</li><li>• Is the process of producing zero torque for a motor that is operating. It is controlled electromechanically (stopping the rotation mechanically) and electrically (giving a reverse current to the actuator so that the current can prevent the flow of the existing current)</li></ul>

## QUESTION 3

State **TWO (2)** reasons why protection should be given to electric motors

## SOLUTION 3

- Avoiding mechanical damage to the motor
- Avoiding the occurrence of unwanted things such as electric shocks due to short circuits

## QUESTION 4

What is meant by electric motor control.

## SOLUTION 4

Electric motor control means current or voltage control that affects the speed and torque of the motor.



## QUESTION 5

Give the advantages and disadvantages of semi-automatic and fully automatic control.

## SOLUTION 5

TYPE	ADVANTAGES	DISADVANTAGES
semi-automatic control	<ul style="list-style-type: none"><li>• safe</li><li>• easy to operate controls.</li><li>• Can control many circuits.</li><li>• No need for skilled workers.</li><li>• Safe.</li><li>• Fits in a small space (the circuit is not so complex).</li></ul>	<ul style="list-style-type: none"><li>• Expensive</li><li>• Need human help to start it.</li><li>• Damage is difficult to repair.</li><li>• Requires touchpad to work.</li></ul>
fully automatic control	<ul style="list-style-type: none"><li>• Does not require human assistance.</li><li>• Can control continuously.</li><li>• Save control time.</li><li>• Can control many circuits by itself.</li></ul>	<ul style="list-style-type: none"><li>• Expensive</li><li>• Difficult to repair</li><li>• The circuit is complicated and difficult to assemble.</li><li>• Needs special maintenance</li><li>• Many drive devices.</li></ul>



## QUESTION 6

What is meant by electric motor control.

## SOLUTION 6

Electric motor control means current or voltage control that affects the speed and torque of the motor.

TOPIC 2:  
COMPONENT AC  
MOTOR  
CONTROL



# COMPONENT AC MOTOR CONTROL

## Push Button

A push-button or simply button is a simple switch mechanism for controlling some aspect of a machine or a process. Buttons are typically made of hard material, usually plastic or metal. The surface is usually flat or shaped to accommodate the human finger or hand, to be easily depressed or pushed. Buttons are most often biased switches, although many un-biased buttons (due to their physical nature) still require a spring to return to their un-pushed state. Terms for the "pushing" of a button include pressing, depressing, mashing, slapping, hitting, and punching.

In industrial and commercial applications, push buttons can be connected by a mechanical linkage so that the act of pushing one button causes the other button to be released. In this way, a stop button can "force" a start button to be released. This method of linkage is used in simple manual operations in which the machine or process has no electrical circuits for control.



Figure 5: push button switch

## Main function

A push button is a component used to turn on and off the operation of an electrical circuit.

There are 2 types of buttons:

### Push Button ON

Contains a pair of normally open contacts that will close when the button is pressed. When a normally open contact is closed, current will flow in the circuit.

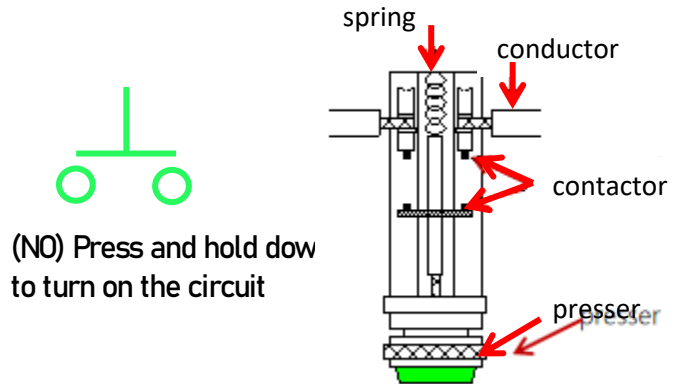

(NO) Press and hold down to turn on the circuit

Figure 6: symbol for push button ON

### Push Button OFF

Contains a pair of normally closed contacts that will open when the button is pressed. When the normally closed contact is open no current will flow in the circuit.

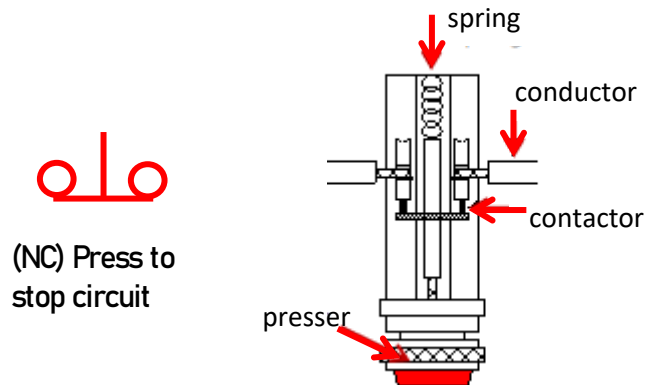

(NC) Press to stop circuit

Figure 7: symbol for push button OFF

### Push Button ON OFF

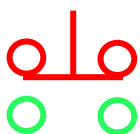

Press buttons that can be used to turn on and stop the circuit

Figure 8: symbol for push button ON OFF





## Contactors

An automatically operated switch that is contact between a fixed contact and a moving contact by an electromagnet. Contactor is a switch operated by an electromagnet. An electromagnet has a loop where the circuit is equipped with a push button.

The current flows into the loop, producing a magnetic force that attracts the magnet to move from opening to closing. The contactor are mechanically connected to the armature so that, when the armature closed, it also closes the contactor.

In semiconductor testing, contactor can also refer to the specialized socket that connects the device under test. In process industries, a contactor is a vessel where two streams interact, for example, air and liquid. See Gas-liquid contactor. A contactor is an electrically-controlled switch used for switching an electrical power circuit. A contactor is typically controlled by a circuit which has a much lower power level than the switched circuit, such as a 24-volt coil electromagnet controlling a 230-volt motor switch.

Unlike general-purpose relays, contactors are designed to be directly connected to high-current load devices. Relays tend to be of lower capacity and are usually designed for both normally closed and normally open applications. Devices switching more than 15 amperes or in circuits rated more than a few kilowatts are usually called contactors.

Apart from optional auxiliary low-current contacts, contactors are almost exclusively fitted with normally open ("form A") contacts. Unlike relays, contactors are designed with features to control and suppress the arc produced when interrupting heavy motor currents. Contactors come in many forms with varying capacities and features.

Unlike a circuit breaker, a contactor is not intended to interrupt a short circuit current. Contactors range from those having a breaking current of several amperes to thousands of amperes and 24 V DC to many kilovolts.

The physical size of contactors ranges from a device small enough to pick up with one hand, to large devices approximately a meter (yard) on a side.

A contactor is a switch operated by an electromagnet. An electromagnet has a loop in which the circuit is completed by a push button. Current will flow into the loop, creating a magnetic field which pulls the armature to move from open to close.

The switch contacts are mechanically connected to the armature so that, when the armature moves to the closed state, it will also close the contact. An automatically operated switch that is contact between a fixed contact and a moving contact by an electromagnet.

- Normally open (NO) are usually installed on the **Main** circuit only.
- Normally open (NO) and Normally close (NC) are usually installed on the **control** circuit.

### Main function

Contactors are used to control electric motors, lighting, heating, capacitor banks, thermal evaporators, and other electrical loads. The contactor is a component whose function is almost the same as the relay function. the difference is, the contactor has a large load so that a large current can pass through it.

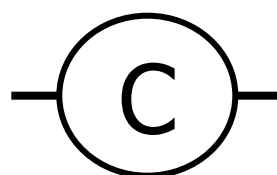
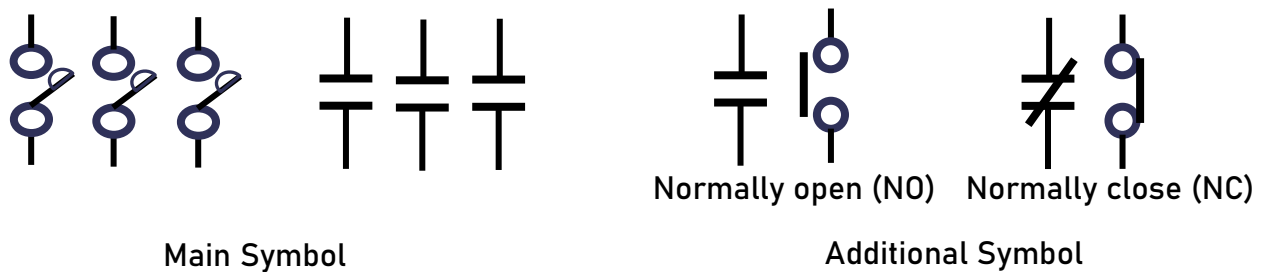
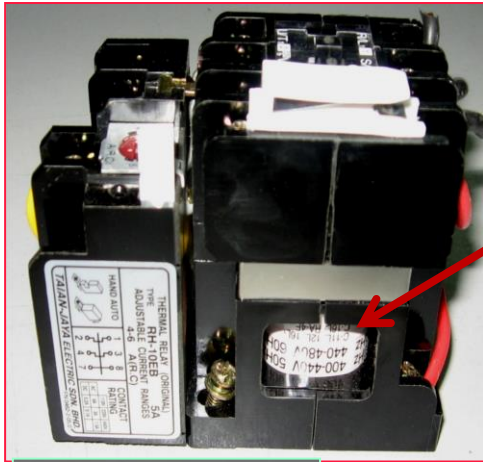

Figure 9: symbol Contactor





400-440V 50 Hz  
440- 480V 60Hz

220-240V 50 Hz  
240-260V 60 Hz

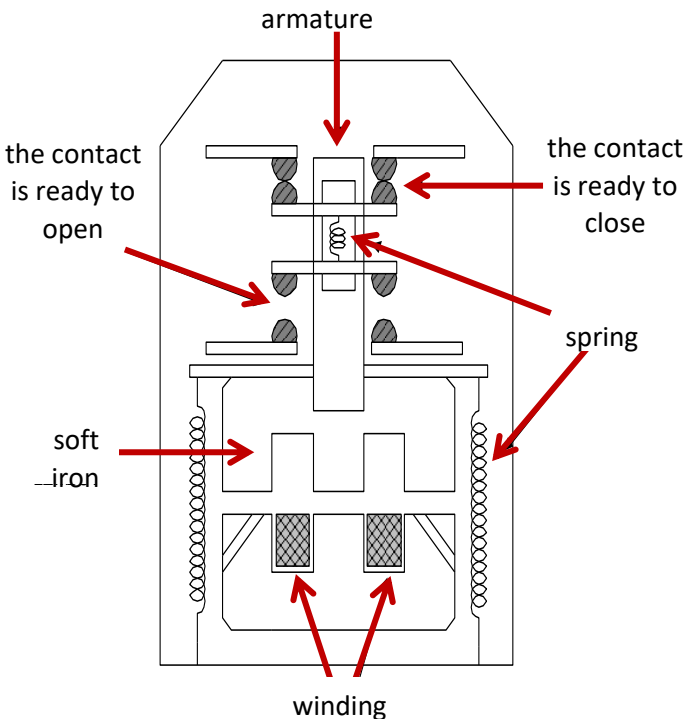
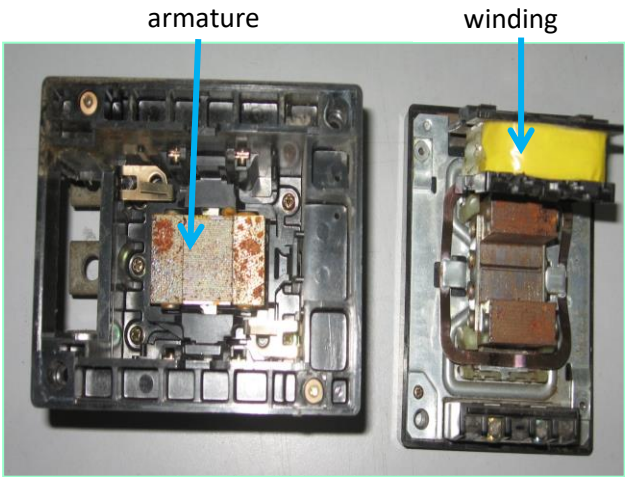

Figure 10: Contactor





## Miniature Circuit Breaker (MCB)

MCB is a type of fuse used in the motor control circuit. it is also called as an isolator that serves to isolate or disconnect the supply circuit with the circuit connected to the load. there are several types of MCBs that are commonly used, namely single-phase MCBs, three-phases and so on and they have different current.

Disconnects the supply to the motor when an overload current occurs. Consists of bimetal joined to one contact as a switch connection point. Disconnects the supply when a short circuit occurs automatically. The nominal current found in MCB is 1A, 2A, 4A, 6A, 10A, 16A, 20A, 25A, 32A and so on. If the incoming current does not exceed the limited amount, the bimetal will not have any effect. But when the current exceeds the limit into the circuit, the bimetal will heat up and then warp and break the circuit.

Operation – when overflow, the heater unit becomes heated, thus switching the switch unit from normally close(NC) to normally open (NO). A circuit breaker is another component used to protect electrical equipment. Unlike the fuse, a circuit breaker will open an overloaded circuit without damaging itself. The circuit heat will cause it to open. Then as soon as the temperature is back to a normal operating range the circuit may be reclosed. Circuit breakers protect our homes. Most circuit breakers work by being thermally overloaded, but some use magnetic overload.

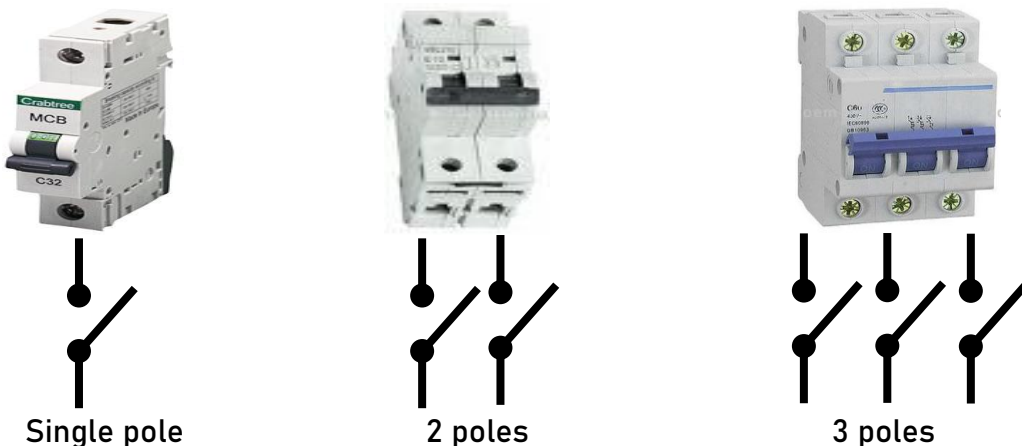



Figure 11: symbol Circuit Breaker



divided into two

- i. heating unit - three-phase supply connected to the motor
- ii. switch unit- using a 240v voltage and plugged into the Pilot Lamp

operation – when overflow, the heater unit becomes heated, thus switching the switch unit from normally close (NC) to normally open (NO).

There are two metals that have different thermal expansion in them. when excessive current passes through it will cause the metal to expand and push the bar further pushing the armature, therefore the normally closed contact will open, and the motor will stop operating.

Then as soon as the temperature is back to a normal operating range the circuit may be reclosed. Circuit breakers protect our homes. Most circuit breakers work by being thermally overloaded, but some use magnetic overload.

### **Main function**

A circuit breaker is another component used to protect electrical equipment automatically. Unlike the fuse, a circuit breaker will open an overloaded circuit without damaging itself. The circuit heat will cause it to open.





Figure 12: position MCCB, RCCB, CT, ELR in Circuit Breaker





Shunt trip coil



Figure 14: shunt trip coil





## Thermal Over Relay (TOR)/ Overload Relay

### Main function

This component is a safety component that works automatically to protect a load such as a motor, from being damaged when excessive current flows through it. its construction consists of two metals that have different thermal expansion. when the current passes through this metal will expand and push the bar and then push the armature / while the normally closed contact will open, the motor will stop.

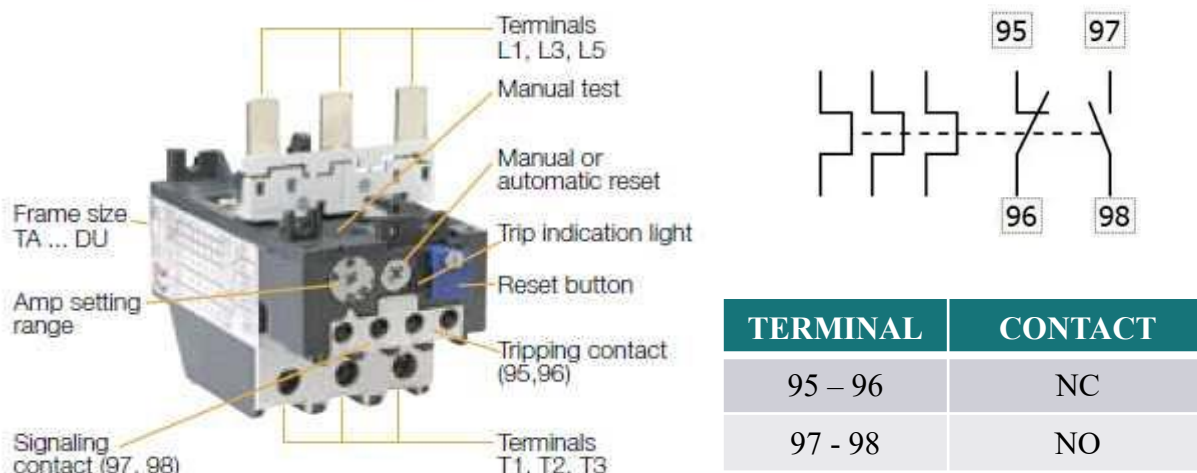

Figure 15: TOR schematic diagram

Table 1: table description of TOR

Press blue button	Contacts	Relay tripped		Relay not tripped	
		Manual	Automatic	Manual	Automatic
	NC 95-96 NO 97-98	open closed	open Closed	closed open	closed open
Button R		Reset	-	-	-
	NC 95-96	Closes when Button's pressed	-	-	-
	NO 97-98	Opens when Button's pressed	-	-	-
Button R/O		Reset	-	-	-
	NC 95-96	Closes when Button's released	-	Opens when Button's pressed	Opens when Button's pressed
	NO 97-98	Opens when Button's pressed	-	Closes when Button's released	Closes when Button's released

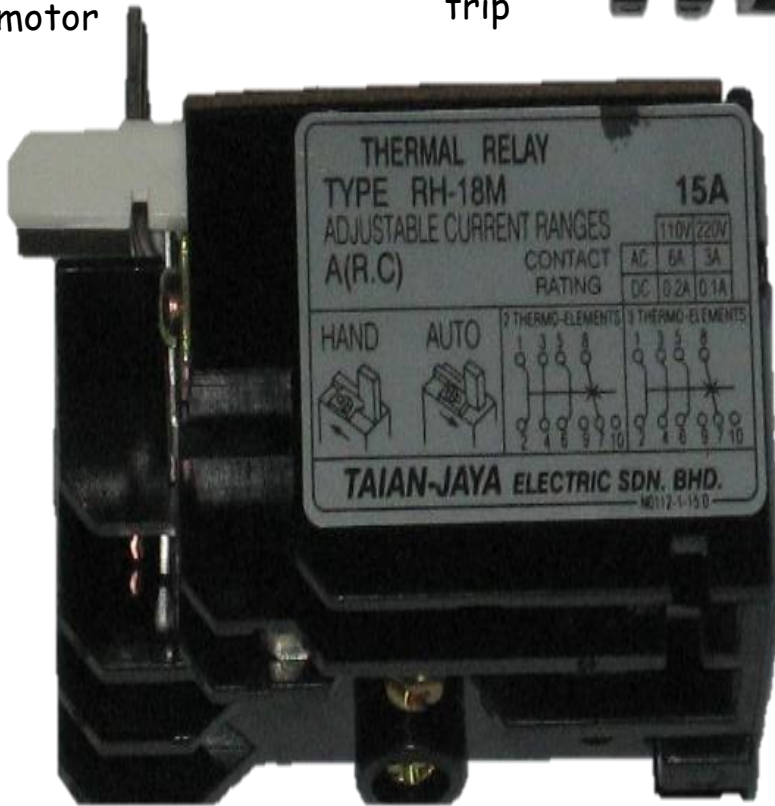
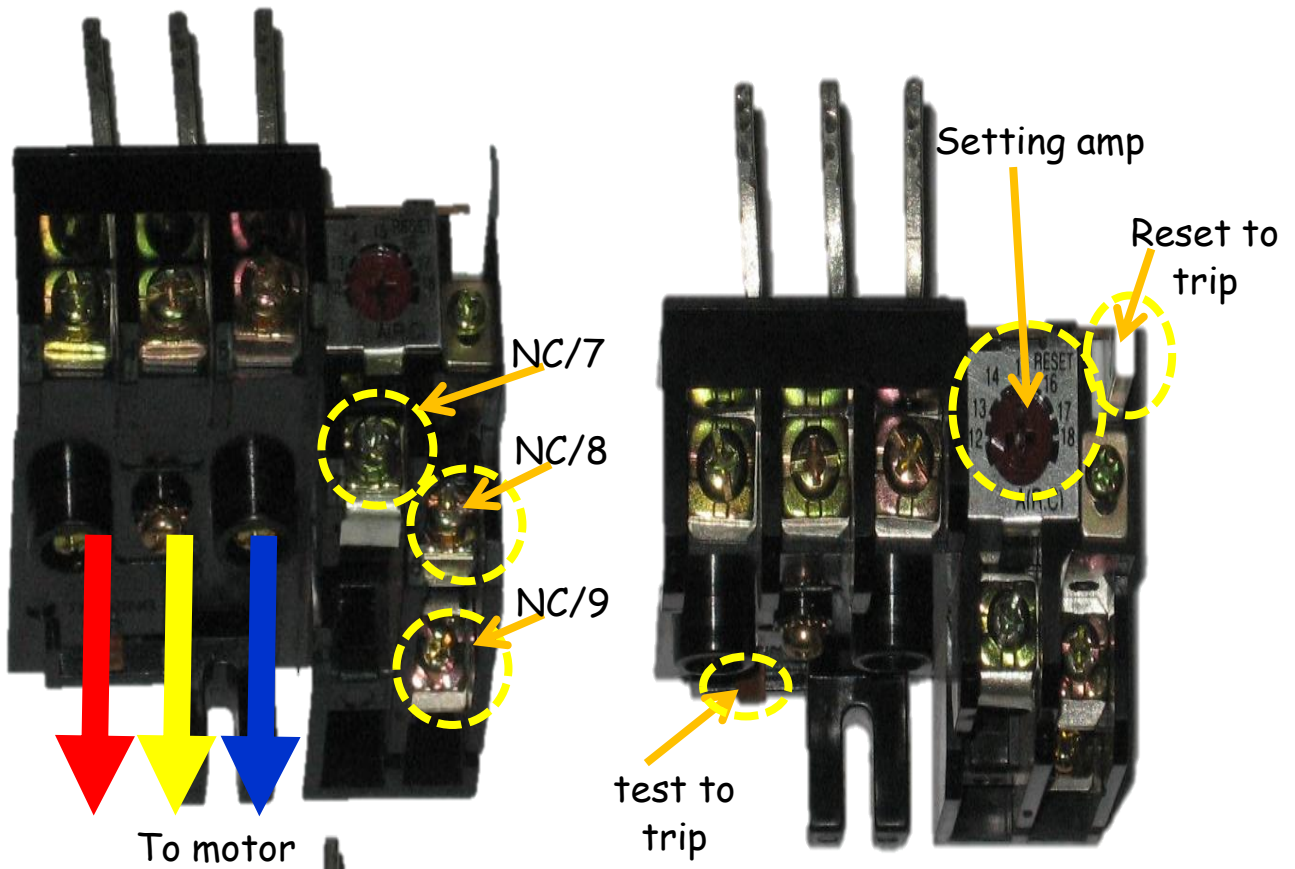
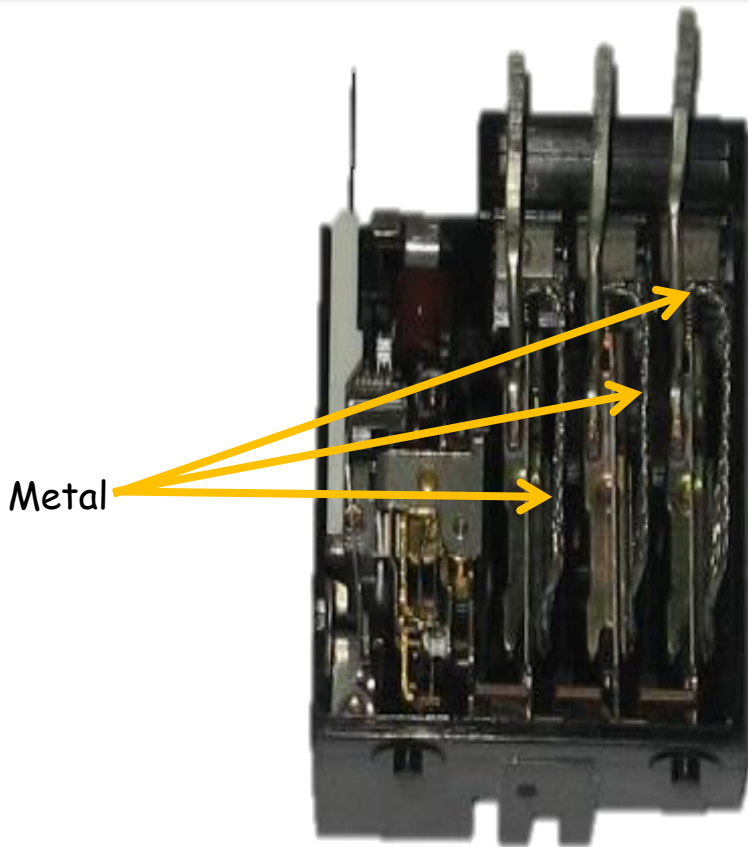
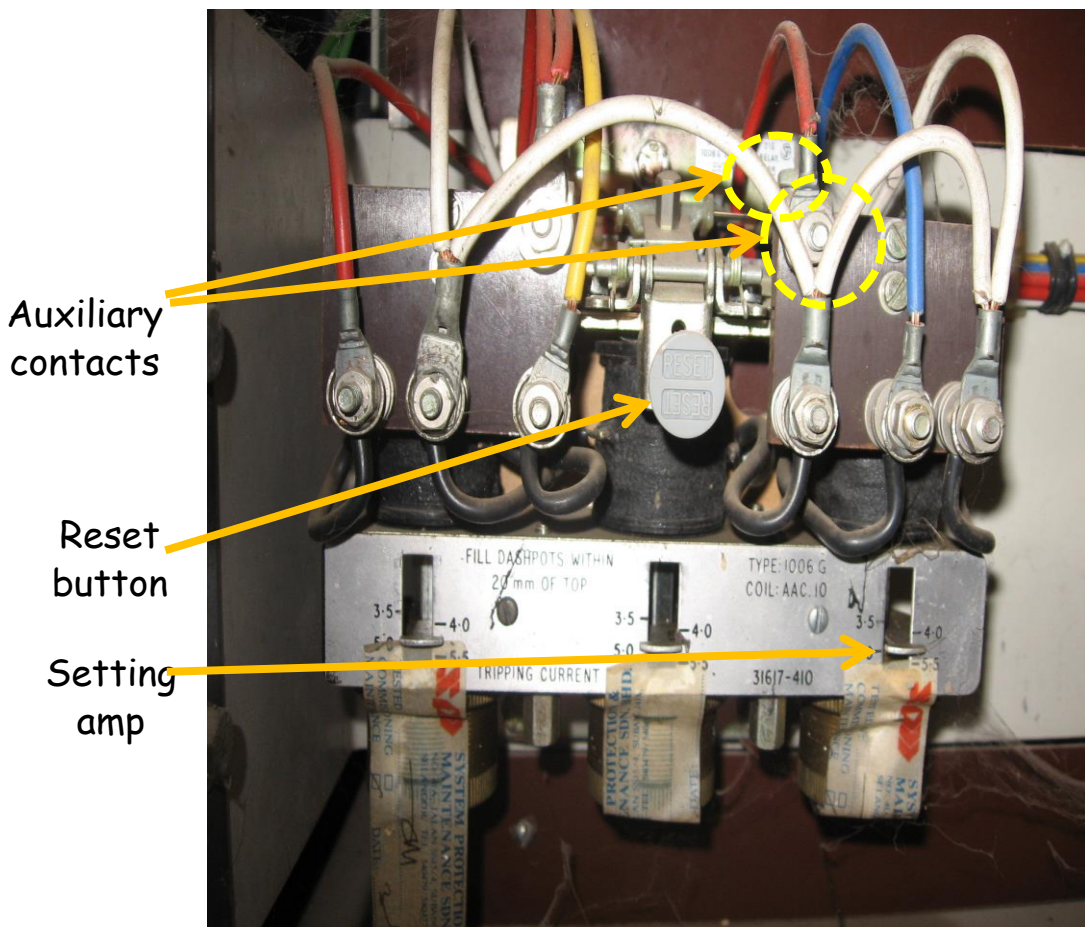

Figure 16: TOR





Metal



Auxiliary contacts

Reset button

Setting amp

Figure 17: construction of TOR





## Timer Delay Relay (TDR)

### Main function

timer delay relay (TDR) or timer is an electronic component in the control circuit that allows and stops the flow of electric current at a specific time. the time can be determined can be determined by adjusting the adjuster.

Some or all industrial control systems need timing operations. Timing devices are used to cut on or off pilot devices at a preset time. Time delay relays and solid-state timers similar and are used to provide the desired delay and timing functions.

Timers are constructed with dials, displays, or some type of operator interface used to set the time and contact state to normally open or normally closed on the device. Though there are many types of timers and different functions they can perform they all come from two basic types timing functions which are the ON Delay Timer and OFF Delay Timer.

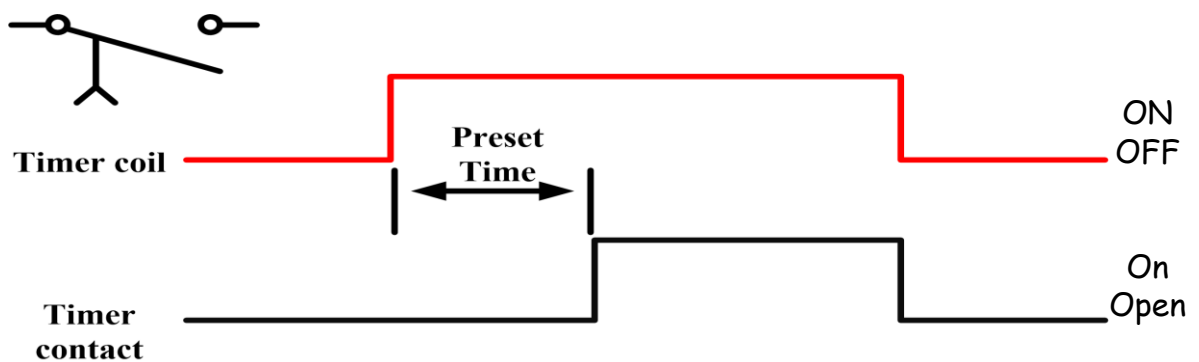

Figure 18: Normally Open Timed Closed (NOTC)

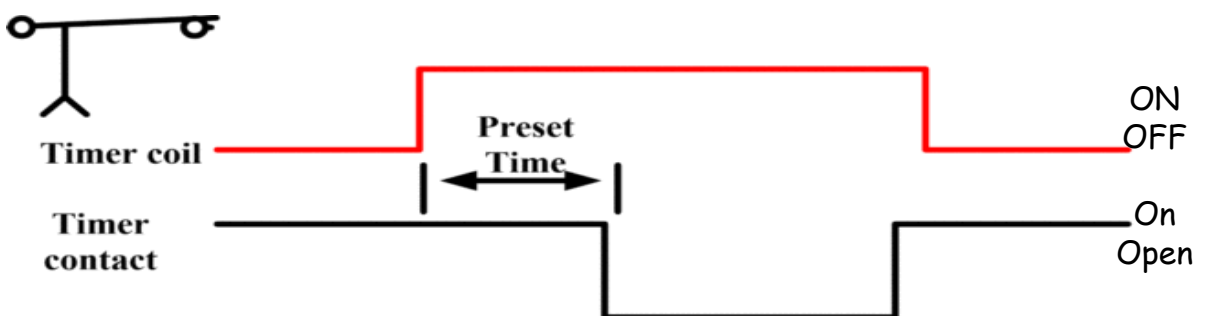

Figure 19 :Normally Close Timed Open (NCTO)

Table 2: table description of TDR

Features:	
Types: AH3-1, AH3-2, AH3-3	Contact capacity: 5A, 250V AC
Coil voltage: - DC: 12, 24V - AC: 12, 24, 48, 110, 220, 240, 380V	Time range: - Second: 1, 3, 6, 10, 12, 30, 60 - Minute: 3, 6, 10, 12, 30, 60 - Hour: 3, 6, 10, 12, 30
Electrical life: 100, 000 times	Mechanical life: 5, 000, 000 times
Coil power: 2VA	

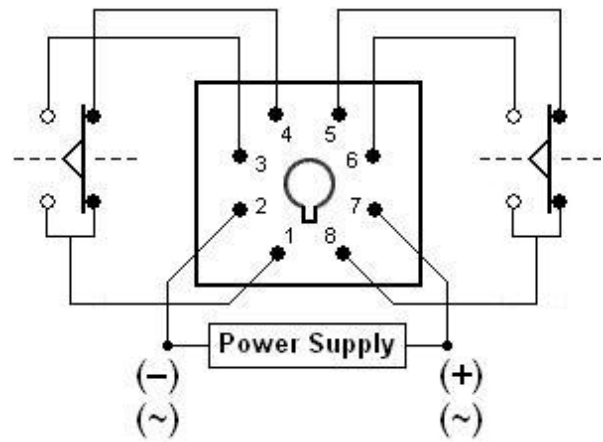
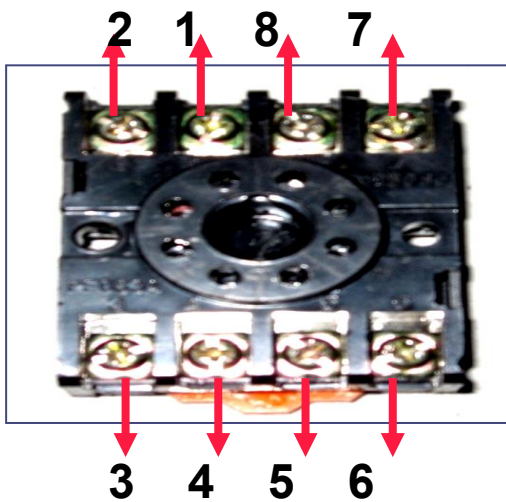

Figure 20: construction of TDR

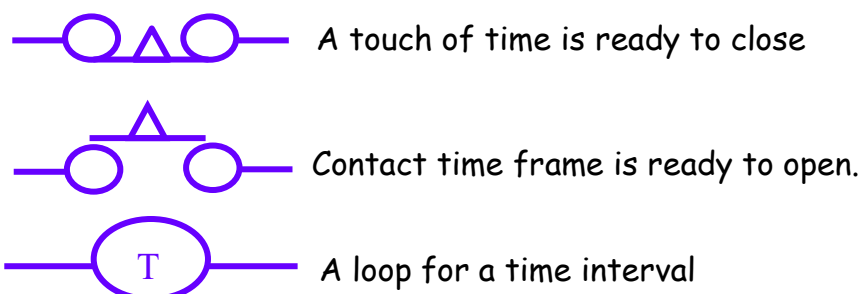

Figure 21: Symbol Timer Delay Relay (TDR)





## Pilot Lamp

### Main function

A pilot light is a small gas flame, usually natural gas or liquefied petroleum gas, which serves as an ignition source for a more powerful gas burner. Originally, a pilot light was kept permanently alight; however, this is wasteful of gas. Now it is more common to light a burner electrically, but gas pilot lights are still used when a high energy ignition source is necessary, as in when lighting a large burner.

The term "pilot light" is also used occasionally for an electrical indicator light that illuminates to show that electrical power is available, or that an electrical device is operating. Such indicators were originally incandescent lamps or neon lamps, but now are usually LEDs.

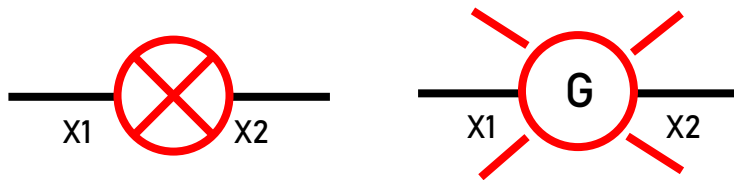

Figure 22: symbol Pilot Lamp



Figure 23: Pilot Lamp



Figure 24: Pilot Lamp at Distribution Board



## Switch Isolator

### **Main function**

The switch isolator is a switch link used to connect and disconnect the supply to the starter contact. the isolator switch must be installed close to the starter so that it is easy to disconnect the supply when repair work for the cooling and air conditioning system is carried out.

if this isolator is installed too far from the starter, this isolator must be locked in the "OFF" position so that this device cannot be turned "ON", especially when maintenance work is done on the starter.



Figure 25: Overload Relay



## Methods of Testing Circuits

After making wiring or troubleshooting, it is necessary to carry out circuit testing before connecting to the supply source. every component used needs to be tested to prevent short circuits from happening as well as to ensure that the components used are in good condition. Usually, the tools used to ensure circuits and components are in good condition is a multimeter.

Before testing the circuit, make sure there is no circuit connection to the supply source. Then the multimeter needs to be adjusted to the range of  $R \times 1\Omega$ . Then the multimeter probe at the source L and N. If the multimeter reading is  $0\Omega$  it means, there is a short circuit in the circuit. If the needle shows a reading of  $2\Omega$ - $5\Omega$ , this means that the circuit is in good condition.

Next is the grounding test, where the multimeter is adjusted to a very high range. one multimeter probe is placed on the L or N source and the other probe is placed on the earth source. meter needle showing infinity reading means the circuit is in good condition.

The tools used to test components are the same as the tools used to test circuits, namely the multimeter. The multimeter is set to the  $R \times 1$  range for all component testing.

### **Miniature Circuit Breaker (MCB)**

Place one probe multimeter on the input source of the MCB and another probe placed on the output source of the MCB. if the multimeter needle rises to 0, it means that the MCB is in good condition. if the multimeter needle does not go up (INFINITI) it means the MCB is faulty. for the control circuit usually the MCB used is MCB 6A



## QUESTION 7

Explain the functions of push button start/on, push button stop/off, pilot lamp, circuit breaker (MCB), magnetic contactor, thermal overload relay and timer delay relay (TDR).

## SOLUTION 7

component	Function
push button start	- switch Contains a pair of normally open contacts that will close when the button is pressed. When a normally open contact is closed, current will flow in the circuit
push button stop	- switch Contains a pair of normally closed contacts that will open when the button is pressed. When the normally closed contact is open no current will flow in the circuit.
pilot lamp	the use of the pilot lamp is to find out if there is a flow of electric current entering the panel, if there is a flow of electric current then the pilot lamp will light up
circuit breaker (MCB)	- as a short circuit protector a protective device used to break the main circuit in the event of excess current caused by overload
magnetic contactor	Is a component whose function is almost the same as a relay. The difference between them is that the Contactor has a large load (large load contact), because it must accommodate the large current that passes through it.  Main contactor - as a contactor circuit connector Auxiliary contactor - as holding and breaking contactor circuit
thermal overload relay (TOR)	- overload protection A safety component that works automatically to protect the load (motor) from being damaged when excessive current flows through it.
timer delay relay (TDR)	Timers are constructed with dials, displays, or some type of operator interface used to set the time and contact state to normally open or normally closed on the device



## QUESTION 8

State and briefly explain the component that will work when it occurs Short circuit and Over-load.

## SOLUTION 8

cause	Component and explanation
Short circuit	Fuse or MCB - A circuit breaker is another component used to protect electrical equipment automatically. Unlike the fuse, a circuit breaker will open an overloaded circuit without damaging itself. The circuit heat will cause it to open.
Overload	<p>Overload Relay – Functions to disconnect the main circuit and the control circuit when there is an excess load.</p> <p>This component is a safety component that works automatically to protect a load such as a motor, from being damaged when excessive current flows through it. its construction consists of two metals that have different thermal expansion. when the current passes through this metal will expand and push the bar and then push the armature / while the normally closed contact will open, the motor will stop.</p>

# TOPIC 3: TYPES OF STATOR



# TYPES OF STARTER

## Direct Current Motor Starter

For direct current motors the starter is of the 3 point or 4 point starter type. Where there are slight differences in terms of components used for series, shunt and compound motors.

## Single Phase Alternating Current Motor Starter

Single-phase motors are usually produced at a small horsepower rate because they are used for small loads such as wind fans and other household appliances, water pumps and compressors for window-type air conditioning. Due to its small capacity this type is usually switched on by connecting a normal switch as a controller (motors of less than 0.5 horsepower). While for motors over 0.5 horsepower, the line starter is still used.

One thing to remember single-phase AC motors require a starter loop that is installed in parallel with the stator coils and needs to be isolated from the circuit once the motor is in motion. However, this process is inside the motor itself using a vortex switch. When the motor has moved and is going to full speed the eddy force from the rotation of the rotor releases the eddy switch contactor and cuts off the supply to the starter coil.

There are two ways to turn on a single-phase induction motor, namely:

- Direct connection to supply without starter
- Using a direct line starter

A small capacity motor can be started directly from the supply. However, this method has high risks such as:-

- Turns on suddenly after power is restored
- No protection in case of overload
- There is no protection in the event of a short circuit



The sudden restart is because the circuit is fully controlled by a mechanical switch that will not release in the event of a power failure. As for damage caused by overloading, it occurs because there is no protection in the circuit that is switched on without a starter. Damage due to short circuit is not properly protected because in practice the fuse found on the usual three-pin plug is 13A. This fuse will break when there is a short circuit, but the state of the current received by the motor before the fuse breaks is higher than the state that the motor can accept.

Single-phase motors are usually produced at a small HP rate because they are used for small loads such as fans and other home appliances, water pumps and compressors for window-type air conditioning. Its small capacity this type is usually turned on by connecting to the line directly using a normal switch as a controller (motors less than 0.37hp). While for motors over 0.37hp starter direct line is used. A single-phase motor requires a starter coil that is installed in parallel with the coil and needs to be isolated from the circuit after the motor moves.

However, this process is inside the motor itself using a rotary switch. by using this switch when the motor has moved and is going to full speed the eddy force from the rotation of the rotor releases the eddy switch contactor and cuts off the supply to the starter coil.

There are two ways a single-phase AC motor can be started:

- i. connect directly to the supply without starter
- ii. using a direct line starter.





## Three phase alternating current motor starter

Meanwhile, starter-type alternating current motors are set according to motor horsepower as required by law 25 LLN board supply rules 1949 revised 1969. according to the law, the types of initiators that can be used are as follows:

The type of starter for a three-phase induction motor has been determined according to the horsepower of the motor as per law 25 LLN Board Supply Rules 1949 revised 1969. According to the law, the types of starters that can be used are as follows:-

- i. Less than 0.5 HP – no starter needed
- ii. 0.5 HP to 3 HP – Direct Line (DOL) starter
- iii. 3 HP to 10 HP – Star Delta starter
- iv. 10 HP to 25HP – Auto Transformer starter
- v. 25HP above - Rotor Resistance starter or Liquid Resistance starter

Note: for motors over 10 Hp. that are submerged in water/ starter liquid, the rotor resistance type is not suitable where the suitable starter is the auto transformer starter type. However, if you want to use a rotor resistance starter, you need to ask for permission from your local electricity supplier.



## Connect Directly To The Supply Without Starter

motors with small capacity can be started without using the starter as described without using the starter as described before. however, it should be noted that starting a motor without a starter as follows:

- i. comes back on suddenly after the supply is restored
- ii. no protection in case of overload
- iii. no protection in the event of a short circuit

For the motor to restart suddenly it can clearly be seen that without a starter the holding circuit is fully controlled by a mechanical switch that will not be released when there is no supply. For damage caused by overload is unavoidable because there is no protection in the life circuit without a starter.

### **using a direct online starter**

while damage caused by a short circuit is not properly protected, because the plug used is a 13A fuse. even if there is a short circuit, but the state of current received by the motor before the fuse is cut is higher than the state of current that can be accepted by the motor.



## QUESTION 9

A 0.5Hp , full load current of 1.3A while the fuse is rated at 13A and this fuse will break at a fuse factor of 1.5. Calculate the maximum value of the current that can pass through this fuse and give the reason.

## SOLUTION 9

$$13A \times 1.5 = 19.5A$$

where for a 0.5HP motor the current value of 19.5A is too high. This can be avoided by using a suitable fuse between 2A and 3A, but in practice, especially for ordinary users, this does not happen.

## QUESTION 10

One of the alternating current (AC) motor controls is Direct Online (DOL). State the advantages and disadvantages of this control.

## SOLUTION 10

advantages	disadvantages
high initial torque and also reach the maximum speed rate in a short time.	the initial current is high which causes the current in the system to be too high and interfere with other supply systems
the construction is simple, and the price is cheaper, and the maintenance work is easy and cheap.	to withstand the high starting current, conductors and protection devices need to be overrated, thus the protection is less sensitive

TOPIC 4:  
DIRECT ONLINE  
STARTER

0.5HP – 3HP

1 $\Phi$  & 3 $\Phi$   
MOTOR





According to electrical regulations, the direct line starter is used for motors over 0.5 horsepower (373W) up to 3 horsepower (2.238kW) only. Where the current starts between 6 to 8 times, but this current will quickly shrink when the speed increases. While the torque is approximately twice the torque at full load. Line starters continue to use contactors and many motors still use manual starters due to certain circumstances, especially economic factors. This starter connects the motor terminals directly to the supply source and will produce a starting current in the motor. This starter is equipped with thermal overload relay along with under voltage protection as shown in figure

By using a direct online starter of the manual type the closing of the main contact is done mechanically. By pressing the on button mechanically the main contact will close the main power circuit and the supply will flow to the motor. The free loop without voltage (holding loop) receives the supply holding the power circuit in the on state. To stop the motor, press the push button 0, causing the holding loop to lose supply as the loop circuit will open.

Having one power circuit and one control circuit, the operation of the starter is carried out electrically by the control circuit. A small capacity motor can be started directly from the supply. However, this method has high risks such as:-

- i. Turns on suddenly after power is restored
- ii. No protection in case of overload
- iii. There is no protection in the event of a short circuit

**note:** the starter control circuit is a small circuit, containing push button on, stop, holding loop and control circuit cable.



The sudden restart is because the circuit is fully controlled by a mechanical switch that will not release in the event of a power failure. As for damage caused by overloading, it occurs because there is no protection in the circuit that is switched on without a starter. Damage due to short circuit is not properly protected because in practice the fuse found on the usual three-pin plug is 13A. this fuse will break when there is a short circuit, but the state of the current received by the motor before the fuse breaks is higher than the state that the motor can accept.



## Change the direction of rotation motor

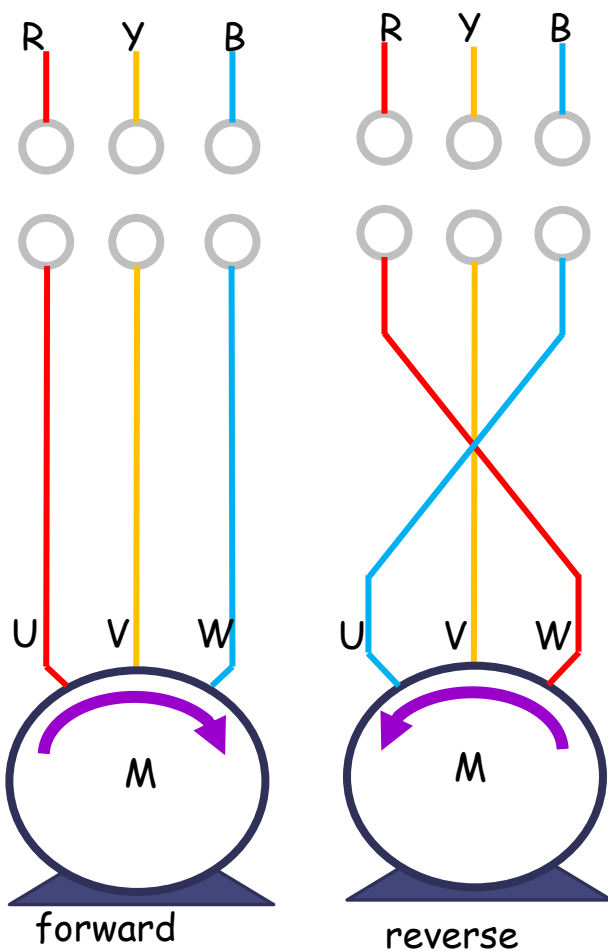

High buildings today no longer use stairs as a tool to go from one floor to another and higher. Most of them, even all of them have already used the lift or elevator as a tool to go up. In addition, electric cars, elevators and similar devices use motors that can change the direction of rotation, that is from the forward direction to the reverse direction.

A three-phase induction motor can be changed in rotation by changing any of the three sources in the motor. Often the motor used for two directions of rotation is supplied with a starter called forward reverse starter. Figure 25 shows the inverted state of motor rotation.

Figure 28: two causes are exchanged



# QUESTION 11

Figure Q11 is a schematic diagram for Direct Online AC motor control. Write what will happen when Start Button is pressed and then Start Button is release, after that Stop Button is pressed, shown in Figure Q11.

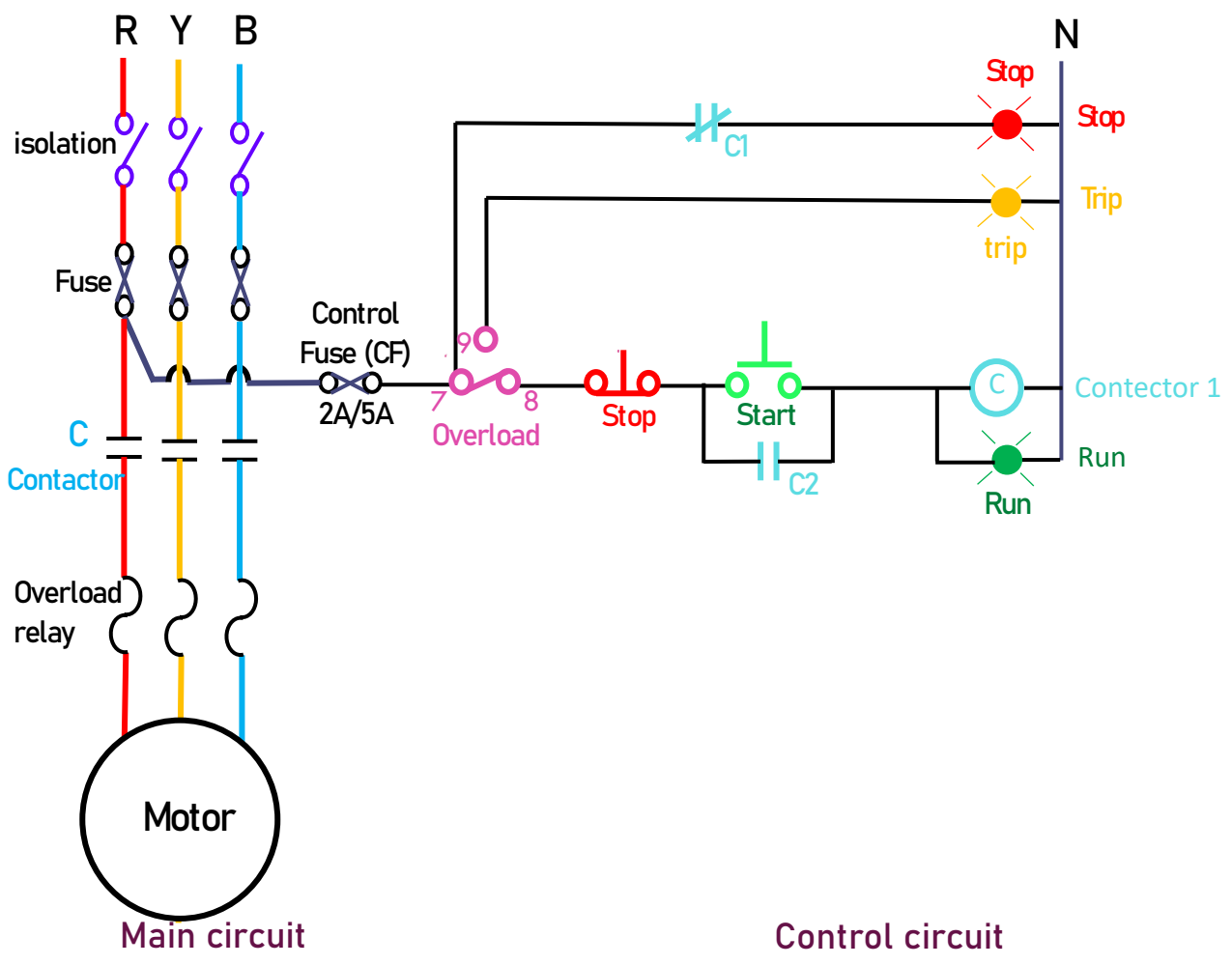

Figure Q11



## SOLUTION 11

### When start button triggered

- It will energize the contactor coil (C) due to electromechanical action
- It will cause All contact to move/change position
- Normally Open (NO) contact will close position – C2
- Normally Close (NC) contact will open position – C1
- Indicator lamp Run will turn ON cause by complete circuit
- Indicator lamp Stop will turn OFF due to contact C1 (NC) in open position.

### Start Button is release

- All contact label C will remain stay at this position.
- Circuit remaining in complete due to contact C2 that parallel with start button react as **Holding Circuit** to the coil contactor C.
- contactor C gets supply even though Start button is released.
- The supply flows and energizes the motor.

### When Stop button triggered

- when the stop push button is pressed or a short circuit occurs the control circuit will open and stop the motor.
- Indicator lamp Stop will turn ON due to contact C1 in close position.



## QUESTION 12

Figure Q12 is a schematic diagram for Direct Online consecutive control. Write what will happen when Start Button is pressed and then Start Button is release, after that Stop Button is pressed.

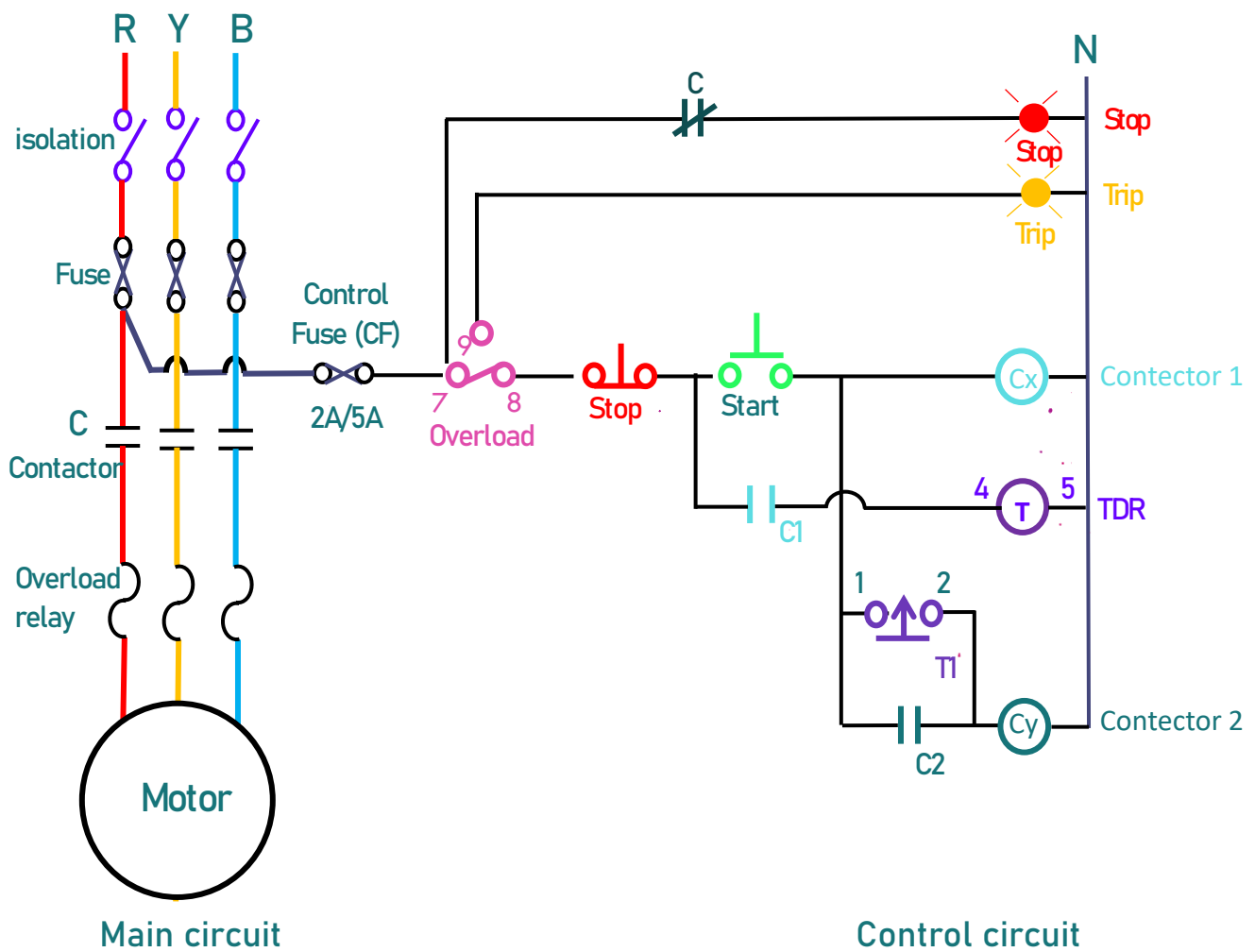

Figure Q12



## SOLUTION 12

### When start button is pressed (triggered)

- It will energize the contactor coil (Cx) due to electromechanical action
- It will cause All contact to move/change position
- Normally Open (NO) contact will close position – C1
- Normally Close (NC) contact will open position – C3
- Indicator lamp Stop will turn OFF due to contact C (NC) in open position

### Start Button is release

- C1 will remain stay at this position.
- Circuit remaining in complete due to contact C1 that parallel with start button react as **Holding Circuit** to the coil contactor Cx.
- contactor Cx gets supply even though Start button is released.
- The supply flows and energizes the motor,
- At the same time the TDR is energized when the circuit is complete through contacts C1.
- when the set period is reached, TDR will be closed and loop T1 will be close
- Normally Close (NC) contact will open position – C1
- Cx will be cut off.
- It will energize the contactor coil (Cy) due to electromechanical action
- Normally Open (NO) contact will close position – C2

### When Stop button is pressed (triggered)

- when the stop push button is pressed or a short circuit occurs the control circuit will open and stop the motor.



# QUESTION 13

Figure Q13 is a schematic diagram for Direct Online Forward Reverse AC motor control. Write what will happen when REVERSE BUTTON shown in Figure Q3 is pressed and what will happen when STOP BUTTON shown in figure S13 is pressed.

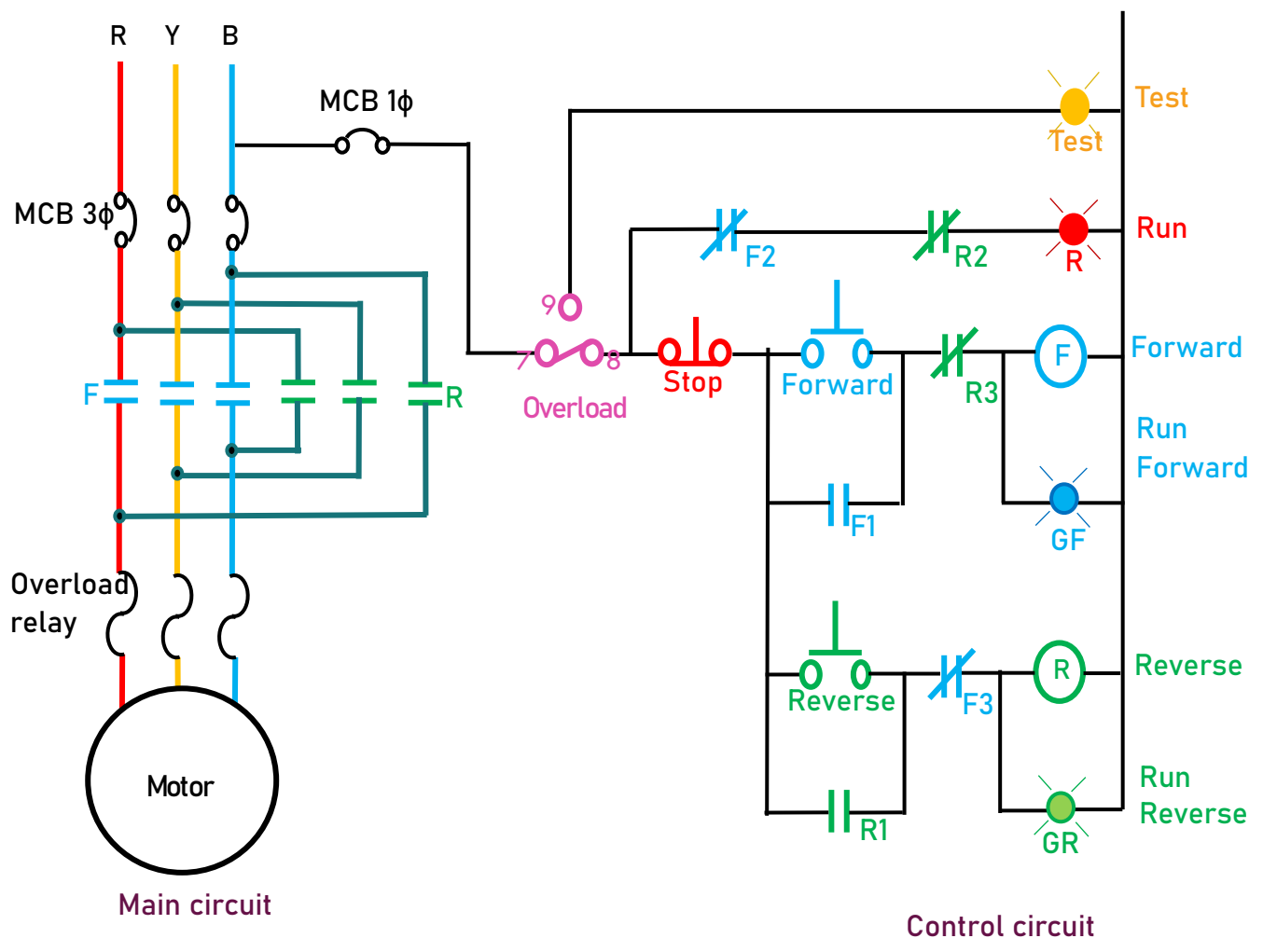

Figure Q13



## SOLUTION 13

### When Reverse button triggered

- It will energize the contactor coil (R) due to electromechanical action
- It will cause All contact to move/change position
- Normally Open (NO) contact will close position – R1
- Normally Close (NC) contact will close position – R2 and R3
- Indicator lamp green (GR) will turn ON cause by complete circuit
- Indicator lamp Red (R) will turn OFF due to contact R2 (NC) in open position

### When Reverse button release

- All contacts label R will remain stay at this position. In other word, there are no action occur currently.
- Circuit remaining in complete due to contact R1 that parallel with Reverse button react as **Holding Circuit** to the coil contactor R. contactor coil gets supply even though we release Reverse button.
- At main circuit, contact label R will Close position. So that 3-phase supply connected to the motor (R-W1, Y-V1 and B-U1). Due to the complete circuit at main circuit then motor start to rotate Reverse Direction.
- Motor Reverse direction because now 2 or 3 phase signal was twist by contactor R at main circuit.

### When Stop button triggered

- It will disconnect power to the both contactor Forward and Reverse. It will no energize both contactor Forward and Reverse.
- It will cause All contactor Forward and Reverse will move to origin position.
- Indicator lamp green (GR) will turn OFF cause by open circuit
- Indicator lamp RED (R) will turn ON due to contact F2(NC) and R2(NC) back to close position.
- Main contact label F at main circuit will back to open position and cause motor to stop rotate.



## QUESTION 14

Sketch the control circuit diagram for the forward-reverse starter connection type. based on the circuit diagram, explain the operating principle of a forward-reverse starter.

## SOLUTION 14

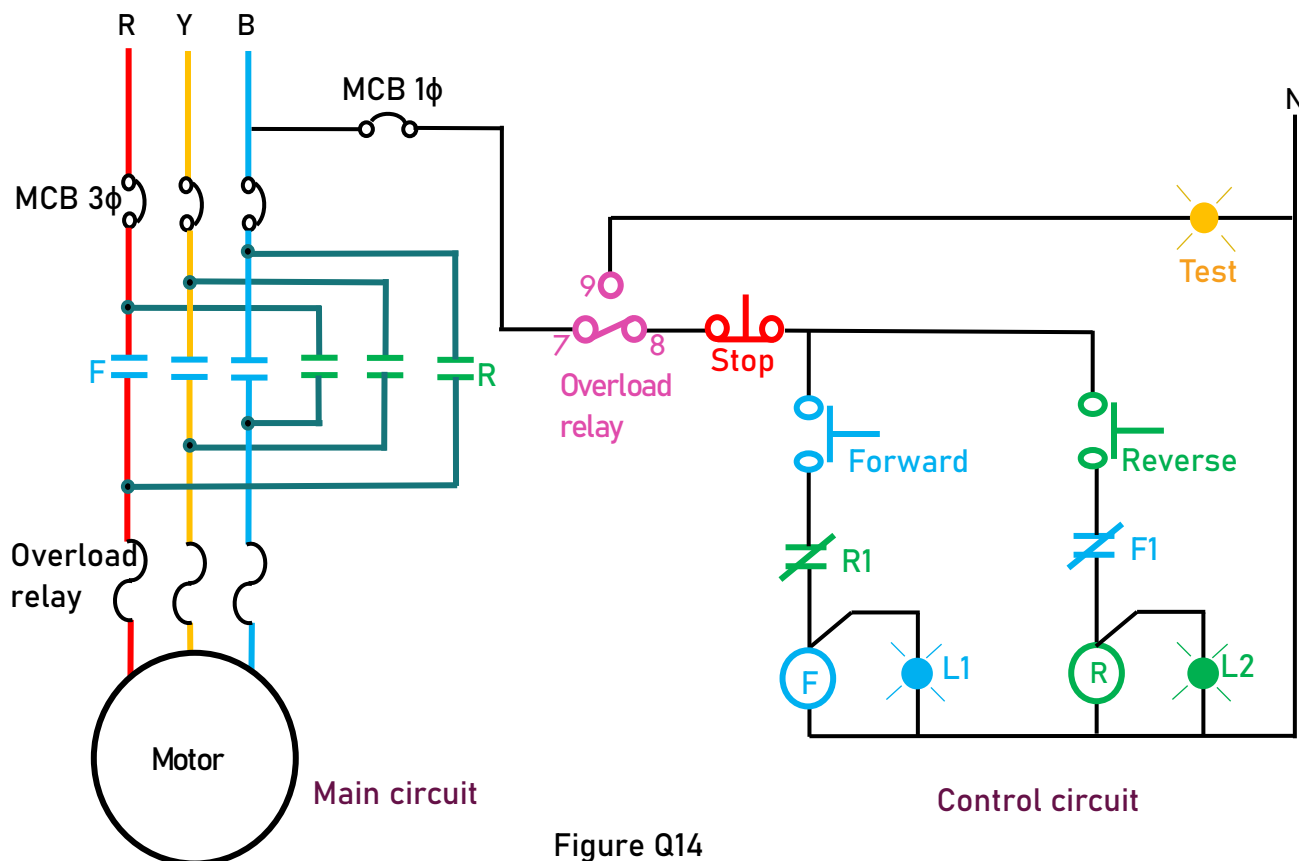

Figure Q14

### When Forward button triggered

- loop F will get electricity.
- A normally closed F1 contact will open
- The motor will get a supply and then rotate Forward (clockwise).
- The pilot light L1 will light up indicating the motor is spinning.

### When Stop button triggered

When the stop button is pressed, coil F will lose electricity and the motor will stop.

### When Reverse button triggered

- loop R will get electricity.
- A normally closed R1 contact will open
- The motor will get a supply and then rotate Forward (counterclockwise).
- The pilot light L2 will light up indicating the motor is spinning.

TOPIC 5:

STAR DELTA  
STARTER

3HP - 10HP

1 $\Phi$  & 3 $\Phi$  MOTOR



# 3HP - 10HP Star Delta starter 1 $\Phi$ & 3 $\Phi$ motor

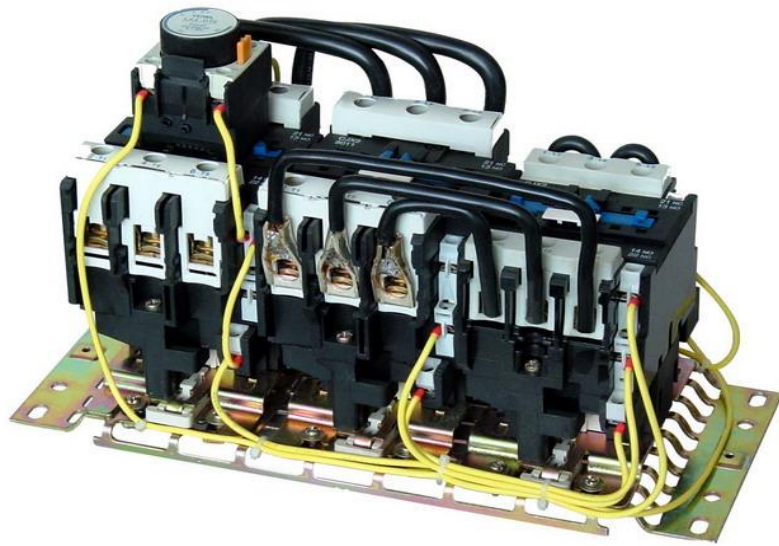

Figure 29: Star-delta Starter 3-10hp

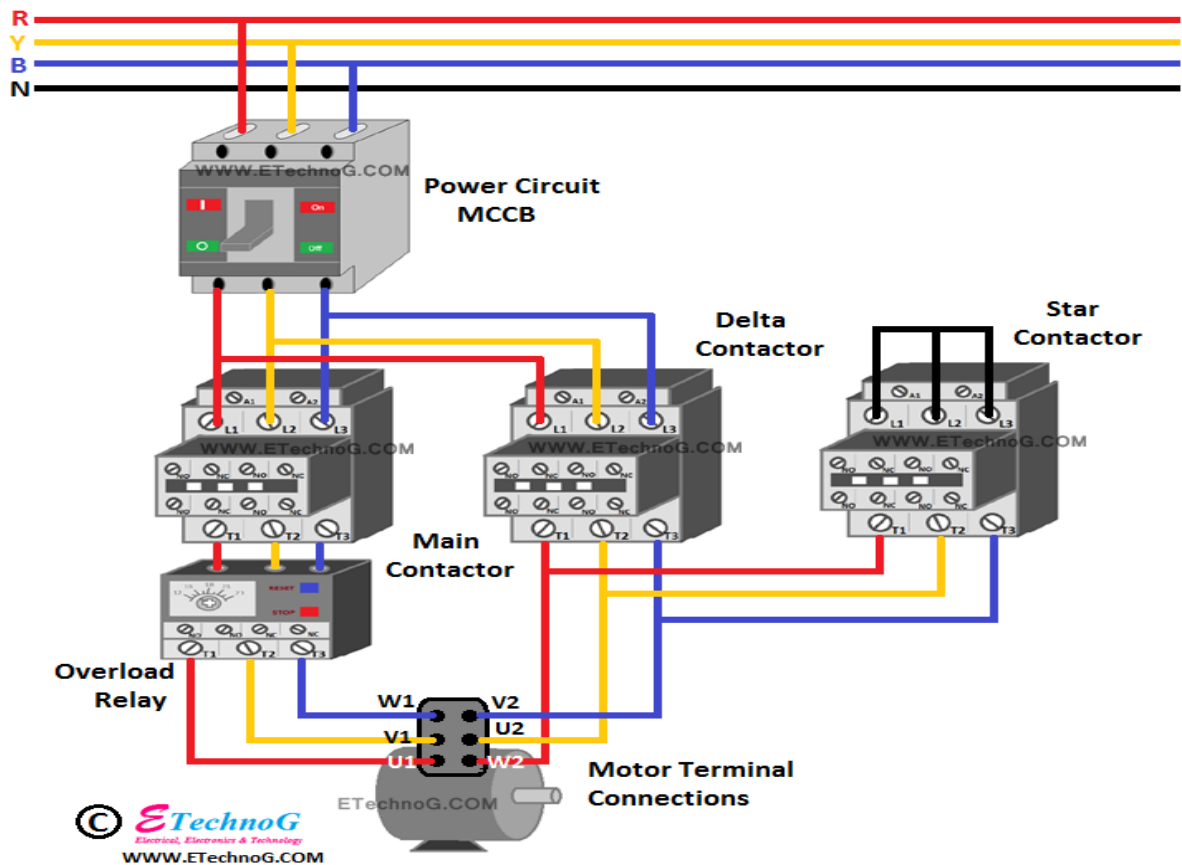

Figure 30: Star-delta Starter wiring diagram



## schematic for Star-delta Starter

This low voltage starter can only be used for squirrel cage motors where all the starter wires (loop terminals) are not connected inside the motor. There are six wire sources in total. The initial stage of the wire source is 3 connected where each phase receives a  $\sqrt{3}$  of the 3 supply sources. The current and reactive power can be reduced in multiples to the voltage ratio which is 30% of the live value in a direct line.

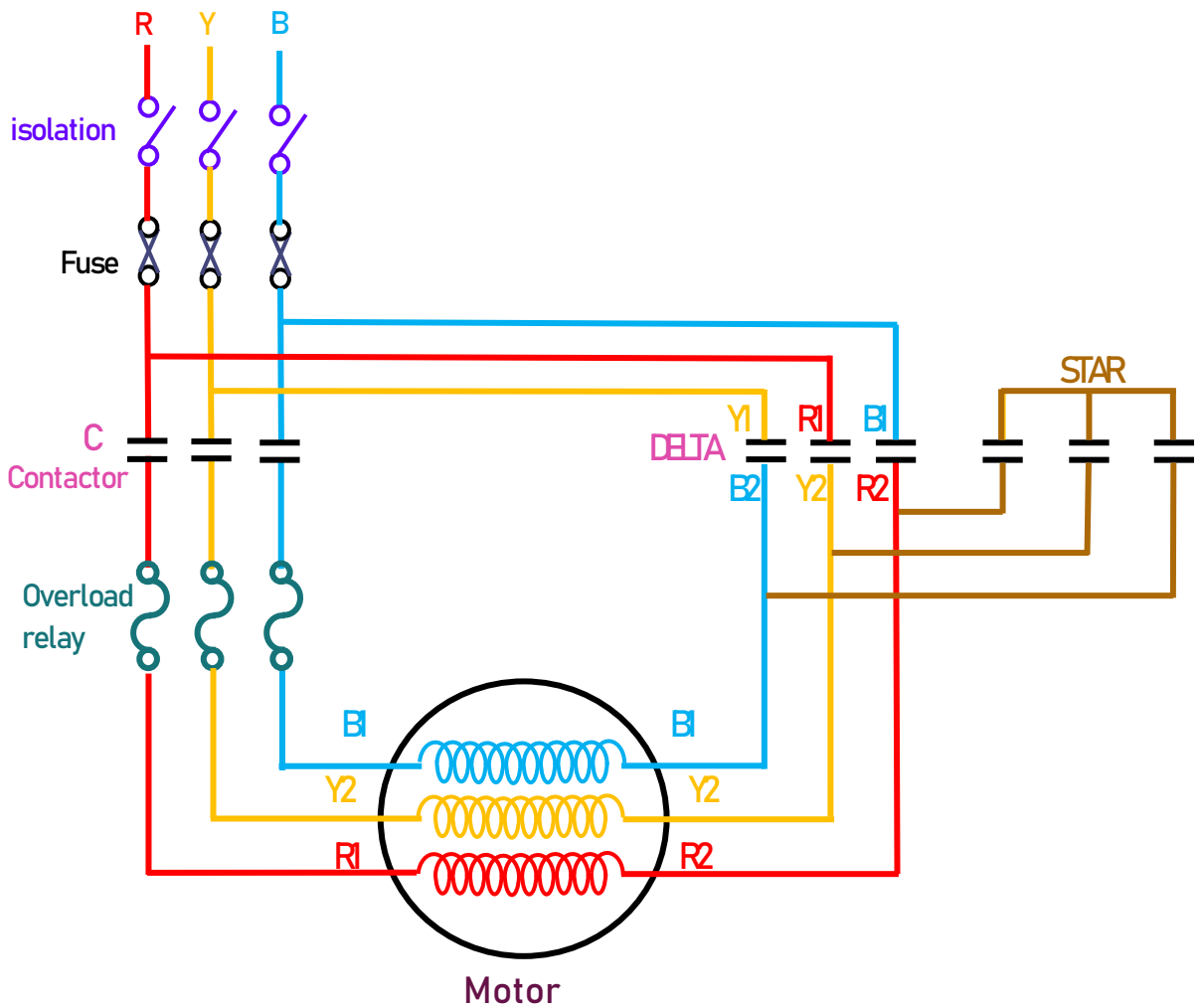

Figure 31: schematic for Star-delta Starter 3-10hp



# schematic for Star-Delta Forward Reverse Starter

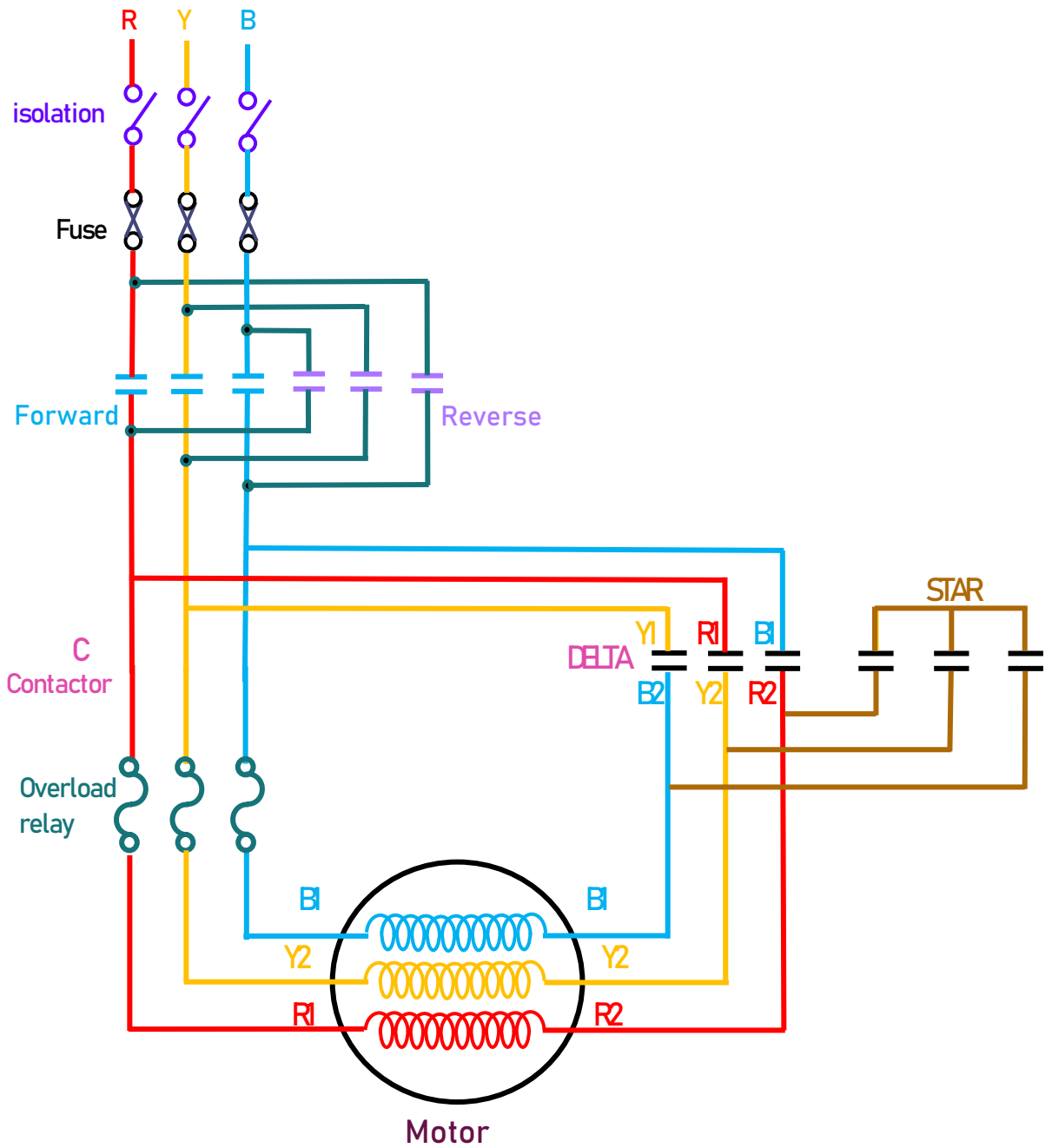

Figure 32: schematic for Star-Delta Forward Reverse Starter



## QUESTION 15

Figure Q15 is a schematic diagram for Star Delta starter operation motor control. Write what will happen when **START BUTTON** shown in Figure Q15 is pressed and then **Start Button** is released, after that **Stop Button** is pressed.

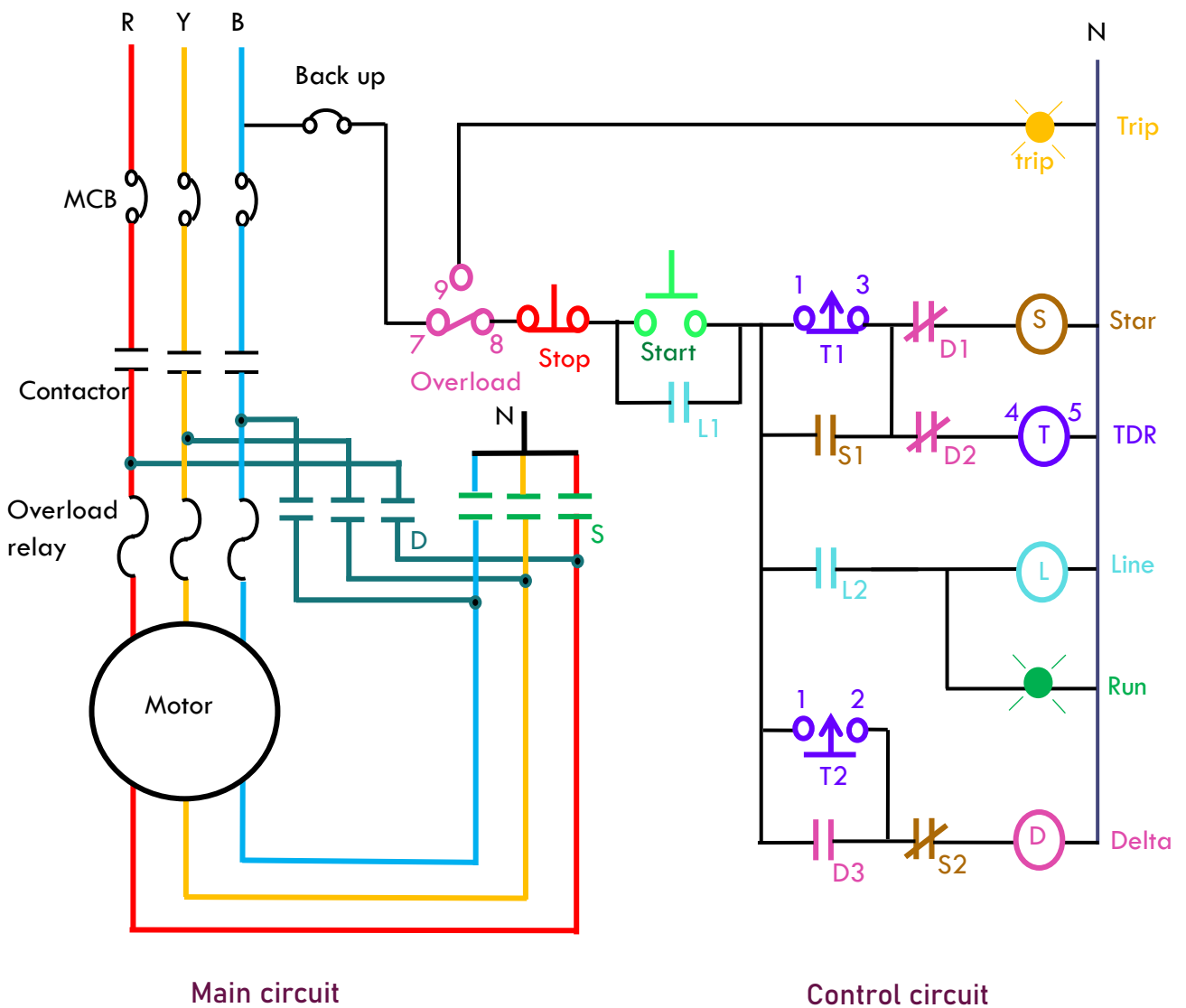

Figure Q15



## SOLUTION 15

### when the start button is pressed

- It will de-energize the Contactor (S) due to electromechanical action.
- It will cause all contact label S and L to move or change position.
- Normally Open (NO) contact will close position – S1, L1 and L2
- Normally Close (NC) contact will Open position – S2
- Indicator lamp run will turn ON cause by complete circuit.
- motor run at STAR connection

### when the Forward Button is release

- Where the free loop without voltage (holding loop, L1) is energized causing the main contact L and S to close,
- at the same time the contact of the L1 handle is closed and the control circuit replaces the Start push button
- The supply flows and energizes the motor,
- At the same time the T is energized when the circuit is complete through contacts L1 and S1 normally close.
- Then flow direct current to the motor in a STAR connection.
- When the time that has been set on the T expires, the TDR1 is open, and contact causes the coil S to open.
- contactor S will return to the original, but connector L still energized.
- At the same time coil D is energized through TDR2 and D3 (NO) to close and S2 still close.
- Now the motor is currently moving in DELTA connection.

### when the Stop button is pressed

- TDR2 and coil D will de-energize.
- Indicator lamp Run will turn OFF cause by open circuit
- At main circuit motor, DELTA contactor will de-activate, from Normally Close (NC) to Open position (NO) and motor stop to rotate.



# QUESTION 16

Figure Q16 below is a schematic for STAR DELTA AC motor control. Write down if the Forward button is press, Forward Button is release and Stop button is pressed.

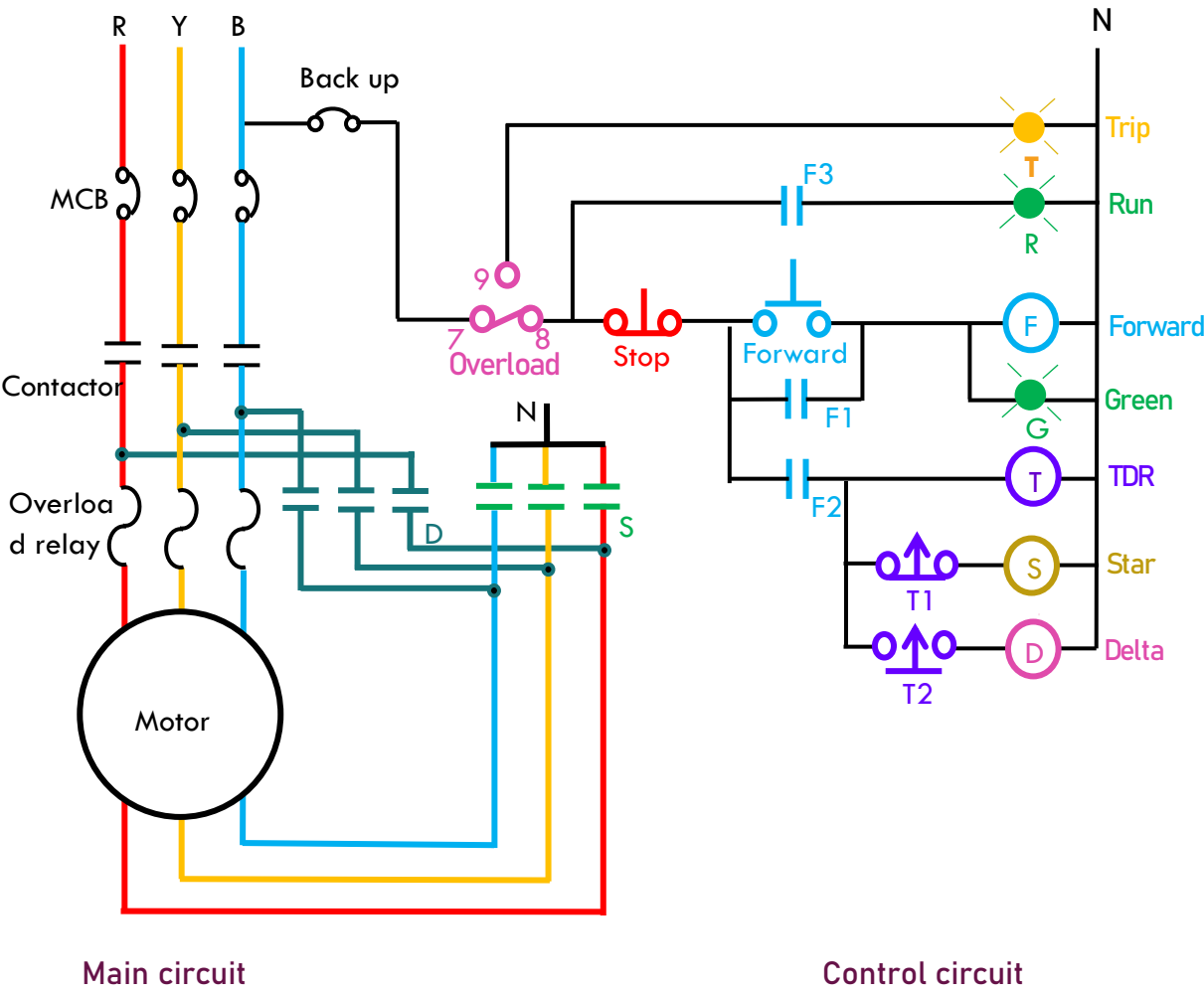

Figure Q16



## SOLUTION 16

### when the Forward button is pressed

- It will de-energize the Contactor (F) due to electromechanical action
- It will cause all contact label F to move/change position
- Normally Open (NO) contact will close position – F1, F2
- Indicator lamp Run and Green will turn ON cause by complete circuit
- motor run at STAR connection

### when the Forward Button is release

- Where the free loop without voltage (holding loop) is energized causing the main contact S to close,
- at the same time the contact of the F1 handle is closed and the control circuit replaces the **Forward** push button
- The supply flows and energizes the motor,
- At the same time the TDR (T) is energized when the circuit is complete through contacts F2 normally close.
- Then flow direct current to the motor in a STAR connection.
- When the time that has been set on the TDR expires, the T1 is open, and contact causes the coil S to open.
- At the same time coil D is energized through T2 (NO) to close and F2.
- The motor is currently moving in DELTA connection.

### when the Stop button is pressed

- T2 and coil D will de-energize.
- Indicator lamp Green (G) will turn OFF cause by open circuit.
- At main circuit motor, DELTA contactor will de-activate, from Normally Close (NC) to Open position (NO) and motor stop to rotate.



## QUESTION 17

A/C installation circuit star delta starter (Star-delta Starter) (4-10hp)



Switch box, 415V/50 Hz supply



3 phase squirrel cage induction motor 10hp, efficiency 92%, power factor 0.83

Figure Q18



## SOLUTION 17

$$\text{Efficiency} = \frac{\text{output power}}{\text{input power}} \times 100\%$$

$$0.92 = \frac{\text{output power}}{1.732 \times 415 \times I_L \times 0.83} \times 100\%$$

$$I_L = \frac{\text{output power}}{1.732 \times 415 \times 0.92 \times 0.83} \times 100\% = 13.2\text{A}$$

$$\text{Starting current} = 1.5 \times 18.2 = 20.38\text{A}$$

$$\text{GBL setting} = 18.2 \times 125\% = 16.5\text{A}$$

$$\text{Rating of overcurrent protection device} = 25\text{A}$$

TOPIC 6:

AUTO  
TRANSFORMER  
STARTER

10HP - 25HP



# 10HP - 25HP AUTO TRANSFORMER STARTER

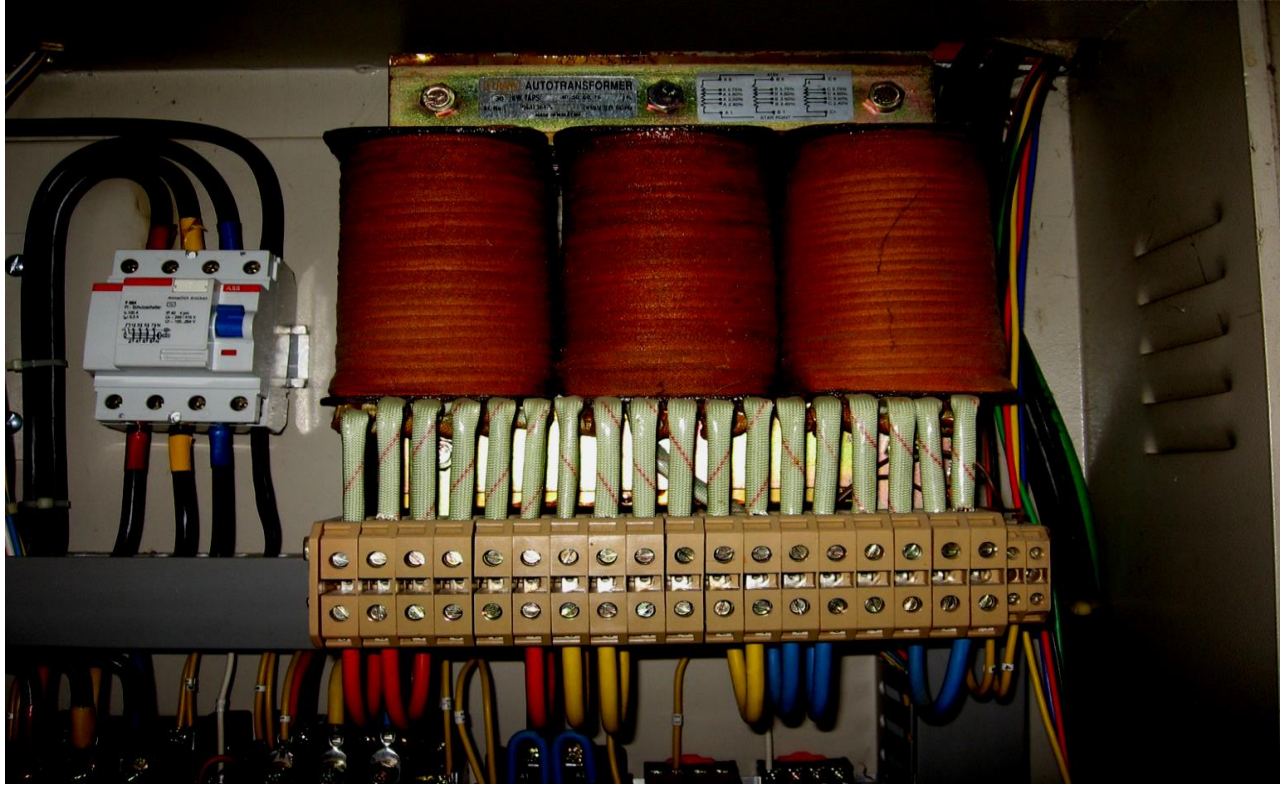
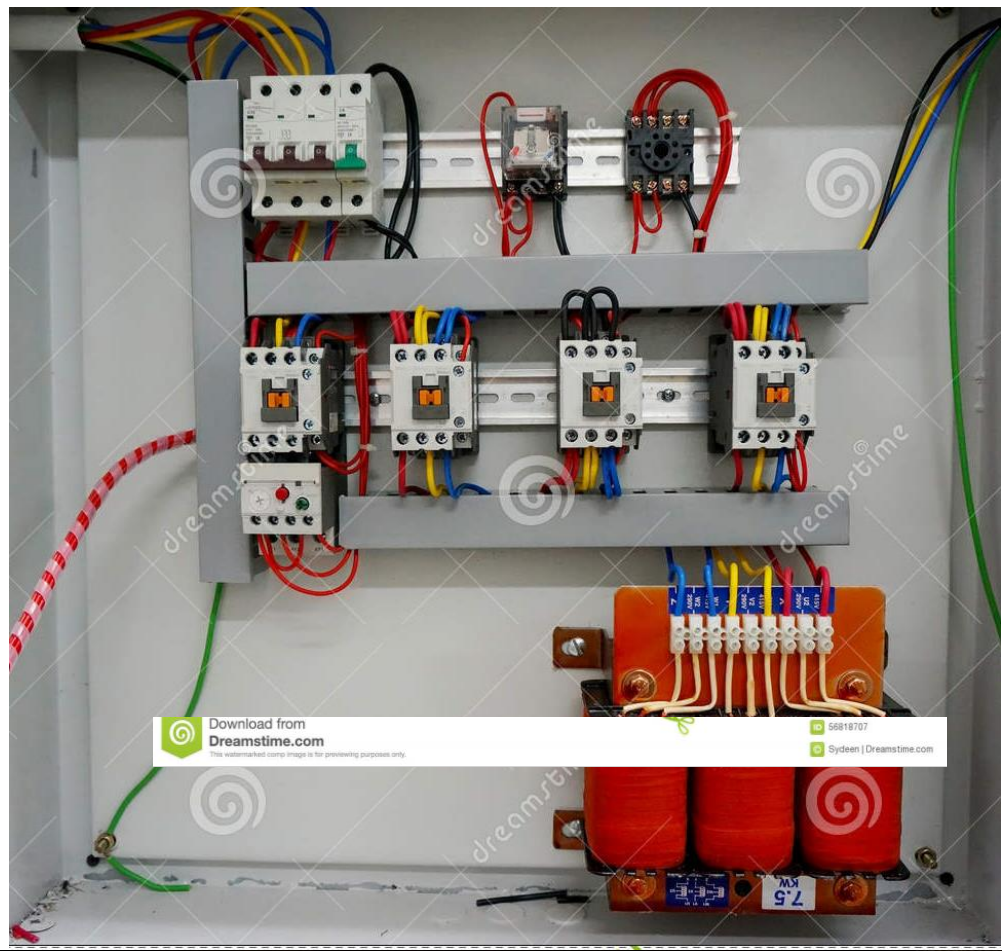

Figure 33: Auto Transformer starter



## Auto Transformer Starter wiring diagram

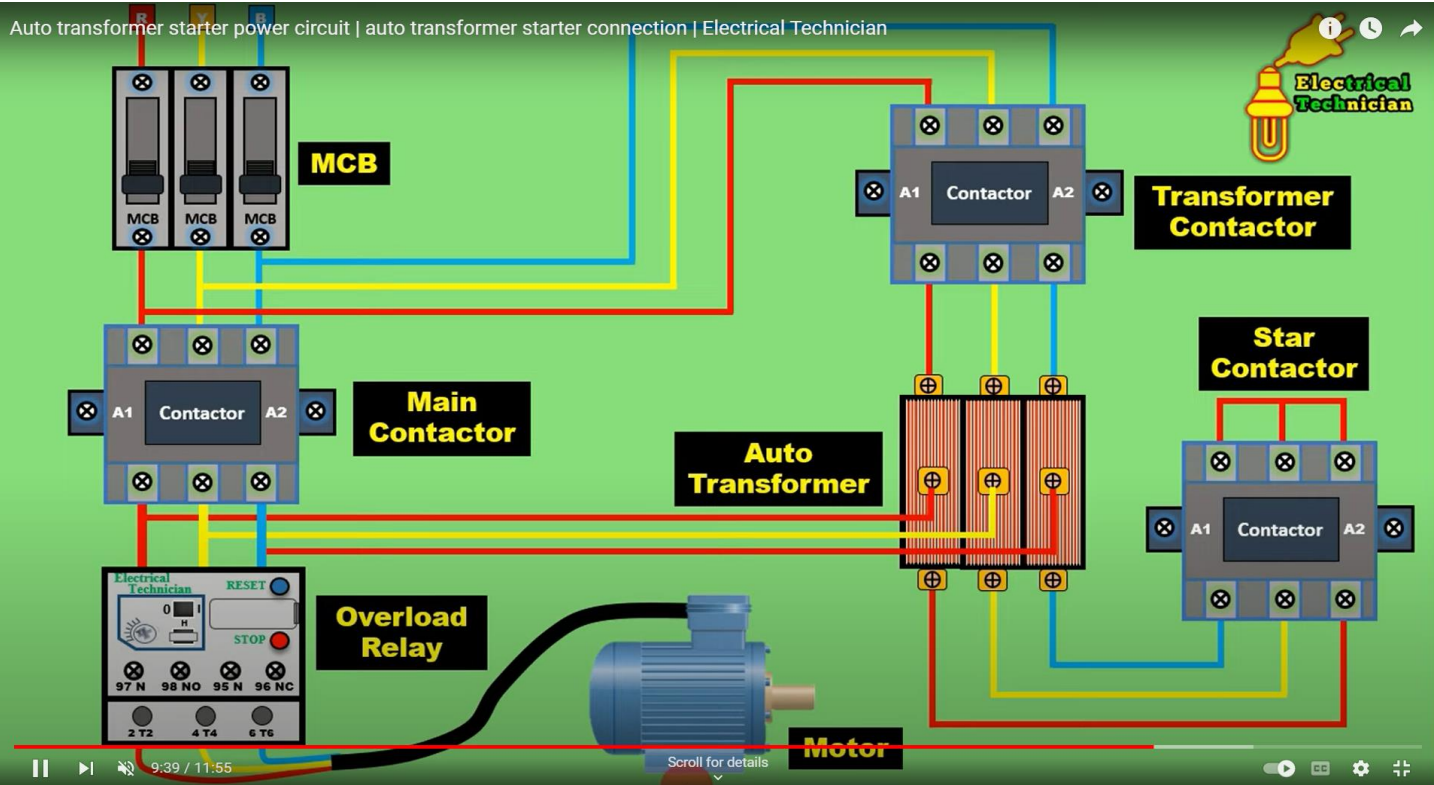
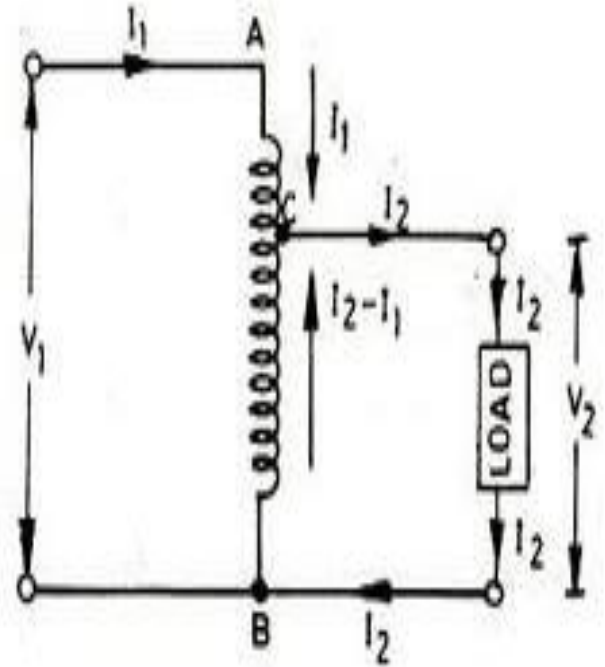
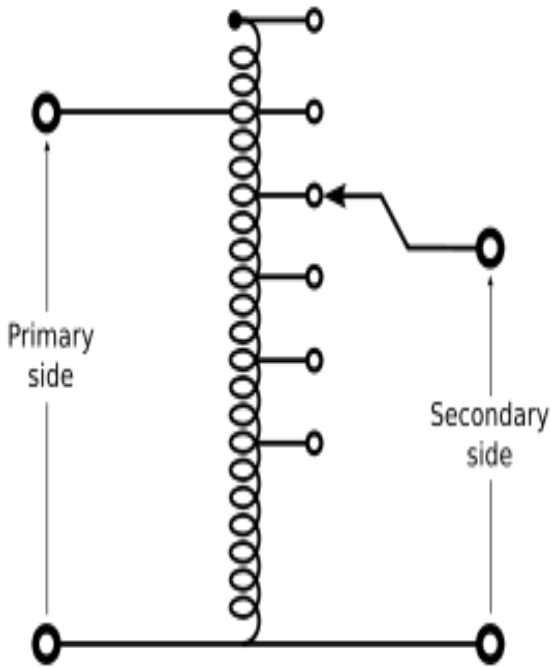

Figure 34: Auto Transformer Starter wiring diagram

- This starter is used when we need to adjust the starting torque for starting a 3-phase motor that carries loads of different capacities.
- This starter is usually used to start a medium-sized motor that usually exceeds 10-25HP or a large motor up to 75kw.
- This initial torque adjustment can be done by reducing the voltage supplied to the motor through the tap-tap of the auto transformer which is matched with the ability of the load to be turned. Indirectly this way can also reduce the starting current of the motor will rotate safely according to the load capacity.
- Once the motor is rotating and its speed is almost at full speed, this auto transformer will be disconnected from the motor and the supply voltage will be supplied to the motor completely.
- The rotation of this connection can be done by using a hand-operated switch or a contact that will operate automatically.
- Usually, this auto transformer tap winding has 3 taps which are 40%, 60% and 75% of the line voltage. There are also some other values according to the desired load.



# Auto Transformer Schematic circuit diagram



Auto transformer main circuit

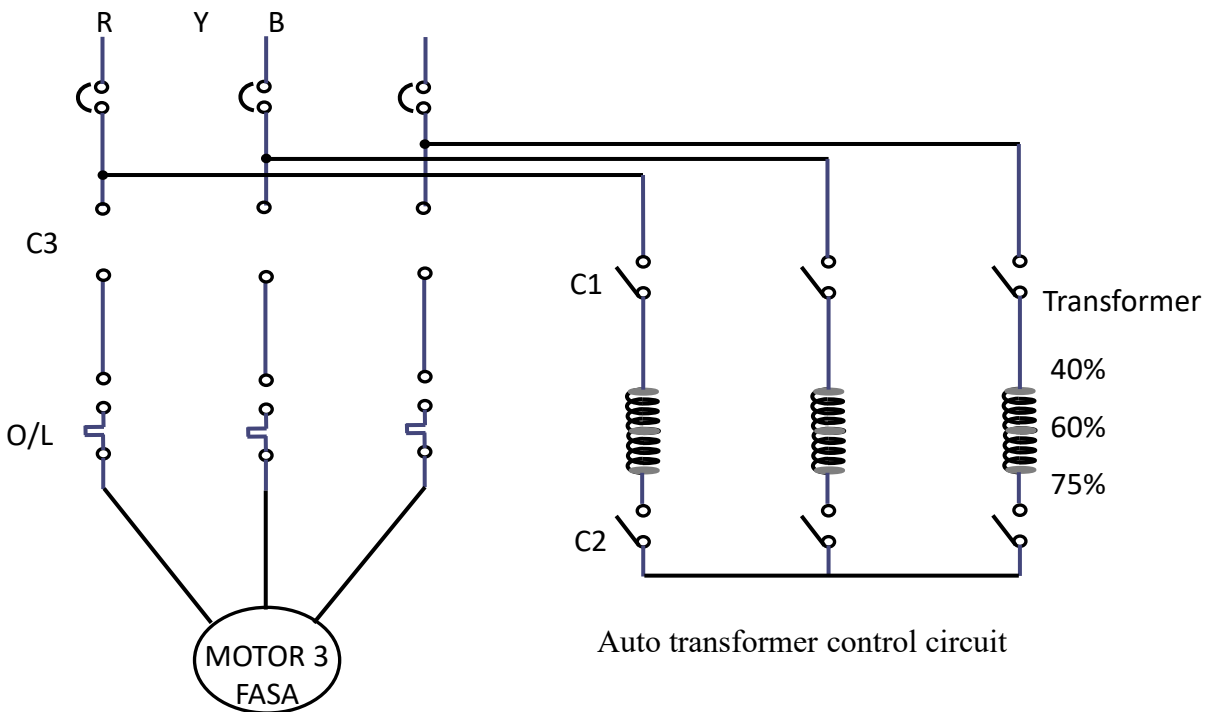

Auto transformer control circuit

Figure 35: Auto transformer Schematic circuit

## Auto Transformer Starter

- This type of starter produces high efficiency and has the option to select the appropriate tap to be used to obtain the required torque and expected life current.
- The main component of this type of starter is a three-phase auto-transformer with three or more taps, usually at 50%, 65%, and 80% of the supply voltage. normally the starter current is limited to 150%, therefore a 50% tap is to meet this requirement.

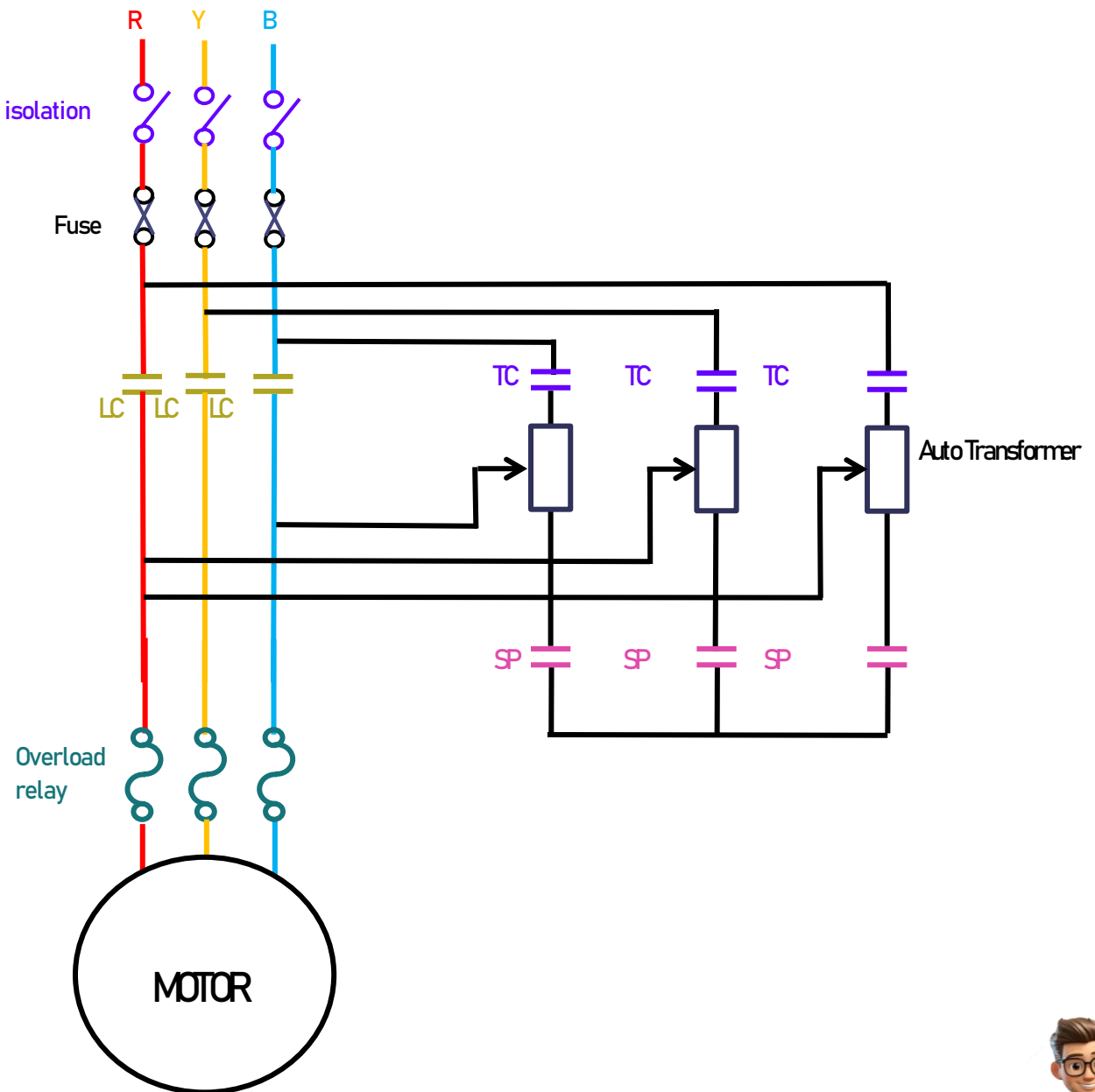

Figure 36: schematic for Auto Transformer





# QUESTION 18

Figure Q18 is a schematic diagram for Auto Transformer starter operation motor control. Write what will happen when START BUTTON shown in Figure Q18 is pressed and then Start Button is release, after that Stop Button is pressed.

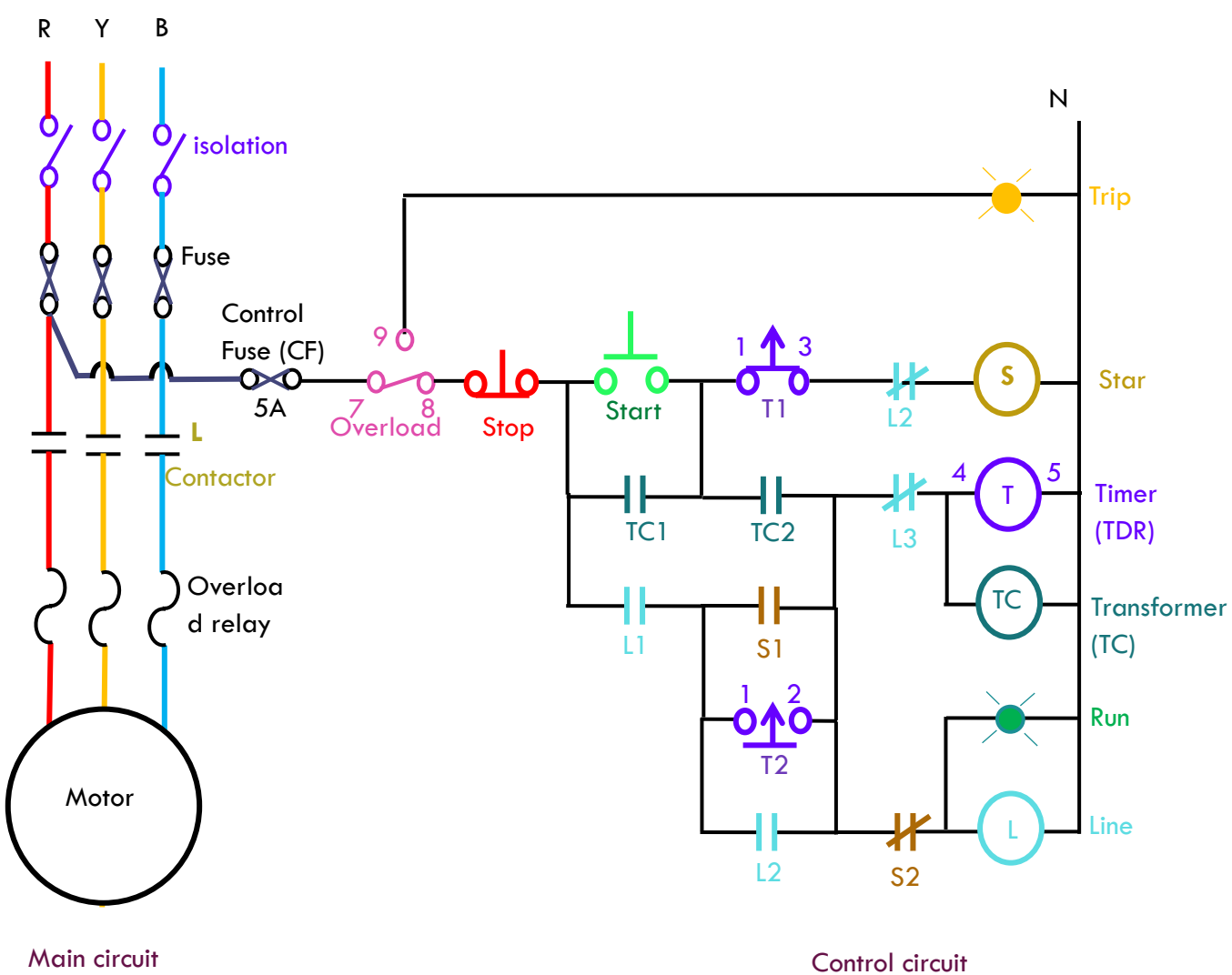

Figure: Q18



## SOLUTION 18

### when the Start button is pressed

- when the Start button is pressed the control circuit becomes complete and energizes the holding loop S in the closed power circuit cause by magnetic field generate.
- at the same time the coils TDR and TC are energized through TC1, TC2, and LC3 (NC) and close the main contactor TC in the power circuit.
- It will cause All contact for to move or change position.
- Normally Open (NO) contact will close position – S1
- Normally Close (NC) contact will open position – S2
- then connect the supply to the motor at low voltage through the auto transformer while the small contacts TC1 and TC2 are closed.

### when the Start Button is release

- TDR and TC still get energy through the holding circuit TC1 and TC2.
- when the time that has been set on TDR ends, T1 will open causing coil S to lose energy.
- subsequently open the main contact of TC in the main circuit
- at this point, the T2 become NC and the LC loop receives supply through contacts LC4 and S2(NC).
- Indicator lamp run will turn ON cause by complete circuit

### when the Stop button is pressed

- LC and Star will de-energize.
- Indicator lamp Run will turn OFF cause by open circuit.
- motor stop to rotate.



# QUESTION 19



HRC fuse ?  
 BS 88  
 Switch box, supply  
 415V / 50 Hz



3 phase squirrel cage induction motor  
 25hp, efficiency 92%, power factor 0.83

# SOLUTION 19

$$\text{efficiency} = \frac{\text{power output}}{\text{input power}} \times 100\%$$

$$0.87 = \frac{\text{output power}}{1.732 \times 415 \times I_L \times 0.82} \times 100\%$$

$$\text{Input current, } I_L = \frac{25 \times 746}{1.732 \times 415 \times 0.83 \times 0.82} = 33.97\text{A}$$

$$\text{Setting GBL} = 33.97 \times 125\% = 42.46\text{A}$$

$$\text{Motor starting current} = 2.5 \times 33.97\text{A} = 84.9\text{A (DOL starter)}$$

$$\text{Starting current to motor using auto trans} = 84.9 \times 70\% = 59.4\text{A}$$

$$\text{(Tapping voltage } 70\% \times 415\text{V} = 290\text{V)}$$

$$\text{Starting current from the supply source} = V_2 I_2 = V_1 I_1$$

$$I_1 = \frac{29 \times 59.4}{415} = 41.5\text{A}$$

$$\text{Rating of overcurrent protection device} = 50 \text{ A}$$

Cable size 10mm PCV current rate 57A



HRC fuse 50A BS 88  
 Source 415V / 50Hz



3 phase squirrel cage induction motor 25hp, efficiency 92%, power factor 0.83

Cable size 10mm  
 PVC wiring conduit

Auto trans Starter

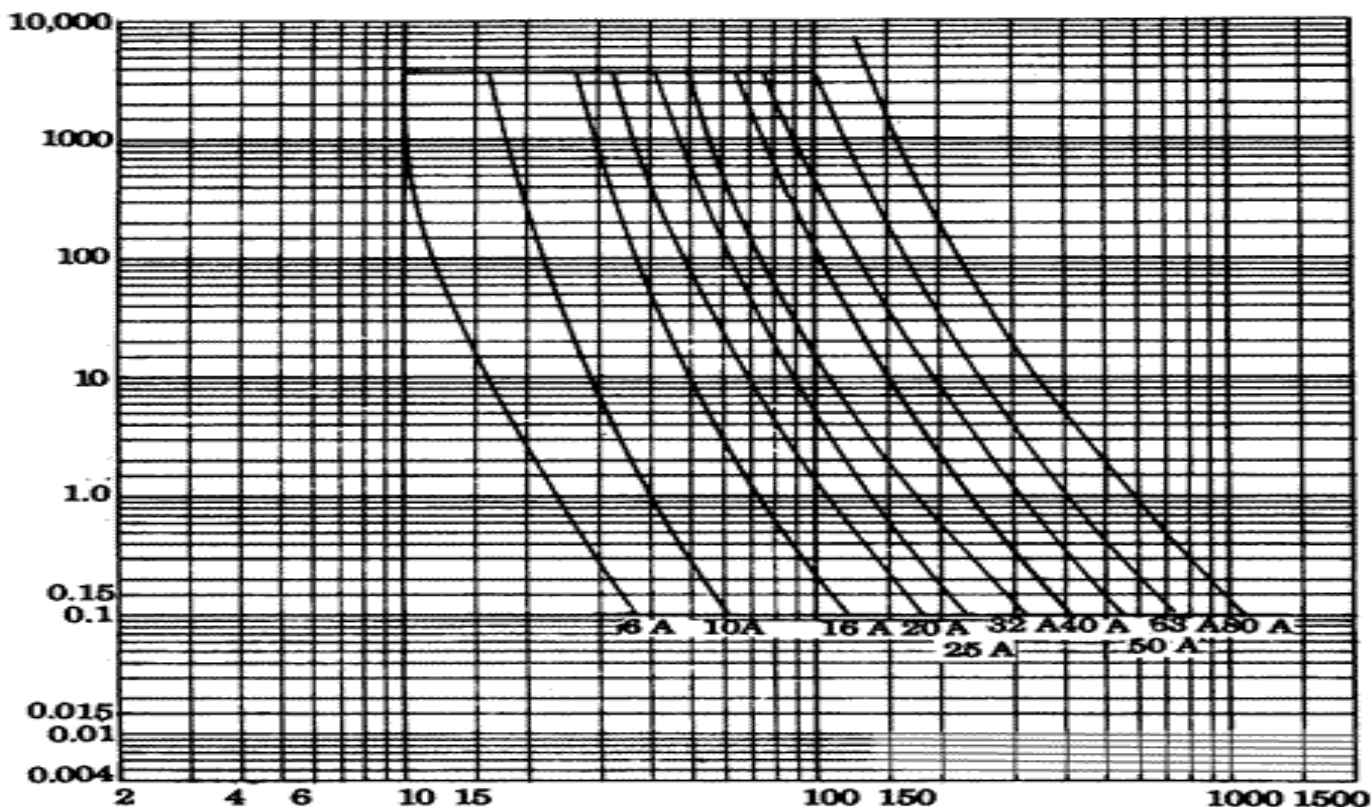

CABLE TABLE 9D1

KEUPAYAAN MEMBAWA-ARUS (AMPERE)

Luas keratan rentas pengalir	Kaedah Rujukan 4 (tertutup dalam konduit pada dinding yang bertebatkan terma)		Kaedah Rujukan 3 (terletak dalam konduit di dinding atau dalam penyaluran)		Kaedah Rujukan 4 (Diklip terus)		Kaedah Rujukan 11 (atas talam kabel berlubang, menegak atau melintang)	
	2 kabel au atau at fasa tunggal	3 atau 4 kabel, au fasa tiga	2 kabel, au atau at fasa tunggal	3 atau 4 kabel, au fasa tiga	2 kabel au atau at fasa tunggal	3 atau 4 kabel, au fasa tiga	2 kabel, au fasa tunggal atau at rata dan bersentuh	3 kabel au fasa tiga rata dan bersentuh atau trefoil
1	2	3	4	5	6	7	8	9
mm <sup>2</sup>	A	A	A	A	A	A	A	A
1	11	10.5	13.5	12	15.5	14	—	—
1.5	14.5	13.5	17.5	15.5	20	18	—	—
2.5	19.5	18	24	21	27	25	—	—
4	26	24	32	28	37	33	—	—
6	34	31	41	36	47	43	—	—
10	46	42	57	50	65	59	—	—
16	61	56	76	68	87	79	—	—
25	80	73	101	89	114	104	126	112
35	99	89	125	110	141	129	156	141
50	119	108	151	134	182	167	191	172

BS 6004



## QUESTION 20

415V, 3 phase induction motor draws 160A connected DOL. If an auto trans with the motor connected to 70% is used to star the motor

- Voltage applied to the motor during starting.
- The starting current taken by the motor.
- The starting current drawn from the supply.



## SOLUTION 20

3 phase 415V motor using DOL starter

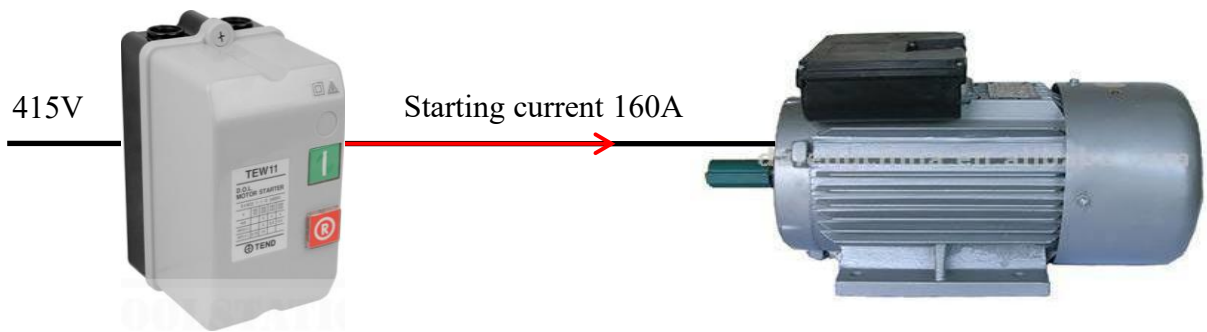

3 phase 415V motor using Auto transformer starter

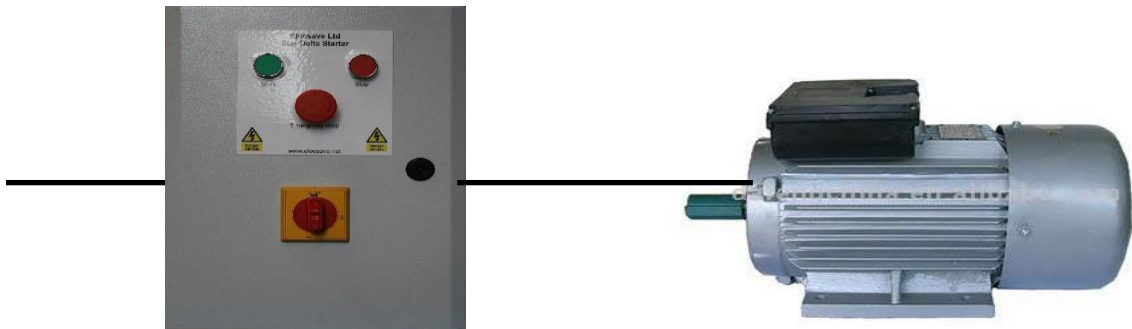

If the motor uses an auto trans starter at 70% tapping  
For 70% tapping motor voltage during starting =  $70\% \times 415V = 290.5V$

TOPIC 7:

ROTOR  
RESISTANCE  
STARTER  
OR  
LIQUID  
RESISTANCE  
STARTER

25HP ABOVE



# 25HP ABOVE ROTOR RESISTANCE STARTER OR LIQUID RESISTANCE STARTER

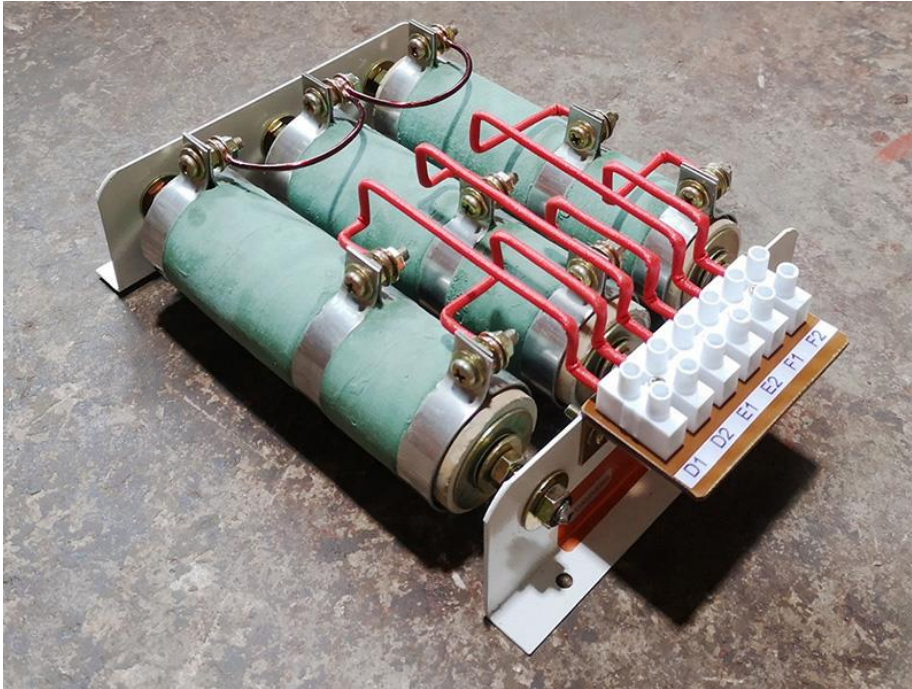
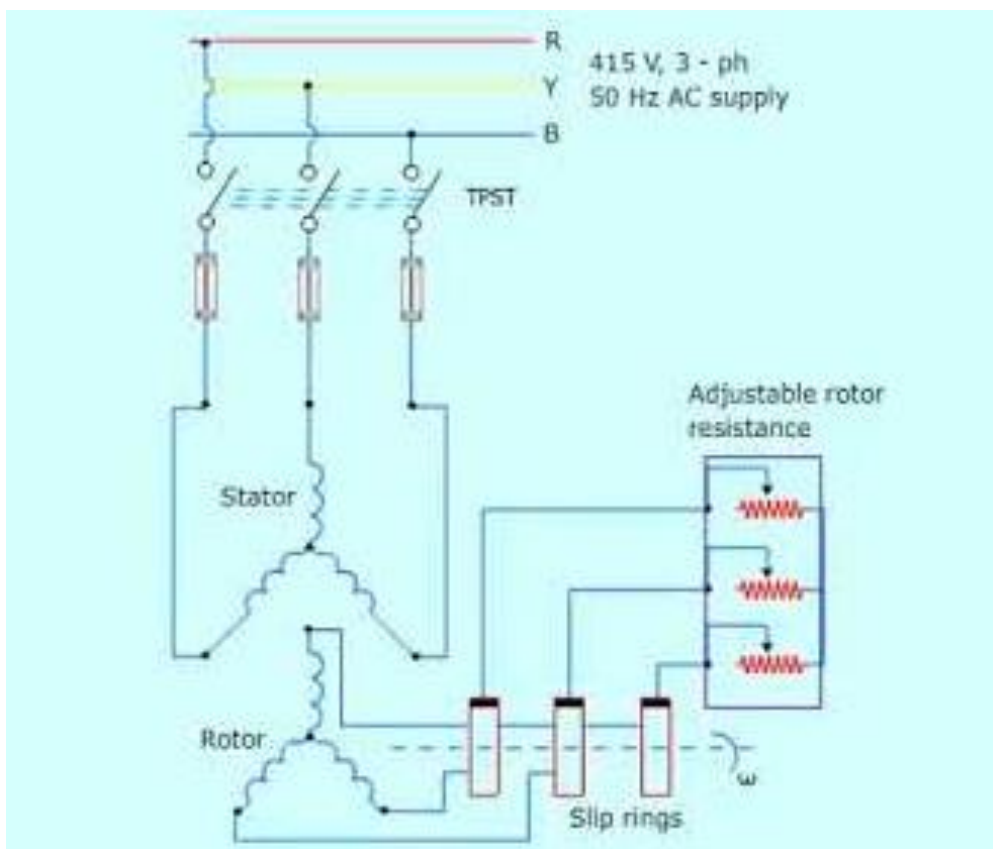

Figure 37: Rotor Resistance Bobbin Type <https://www.eeproent.com/>



<https://www.youtube.com/watch?v=Y7rYv36dAr4>

Figure 38: slip ring induction motor, starting current is controlled by the external rotor resistance



## Slip Ring Motor Starter

Figure 39 shows the schematic circuit of the rotor rheostat type control method used on the slip ring motor.

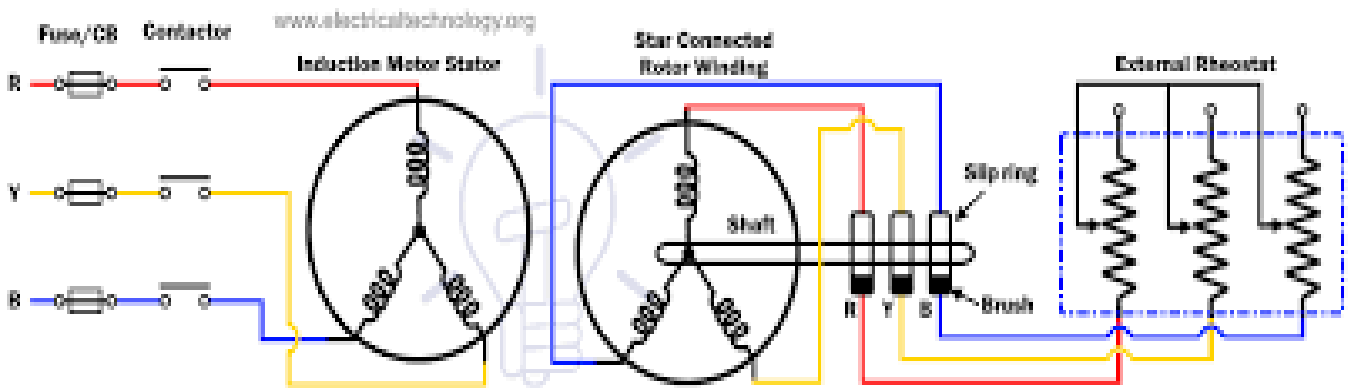

Figure 39: Rotor Resistance of Slip Ring Motor Starter

For the construction of the slip ring type rotor, the conductors of this type of rotor are composed of three-phase windings that resemble the windings in the stator. The star-connected three-phase rotor winding is connected to an external variable resistor (rheostat) through three slip rings. At the time starting the resistance is placed at the maximum value to obtain a low current value and a high starting torque value. When the speed of the motor increases, the value of the resistance will be reduced in stages and then it will be bypassed when the speed of the motor is at full load.

In addition to getting high starting torque, the use of variable resistors can also control the speed of the motor rotor. When the resistance value is high the slip will increase when the slip increases the speed will decrease. The disadvantage of using an external resistor is that it can reduce the efficiency of the motor because there is a loss in resistance.

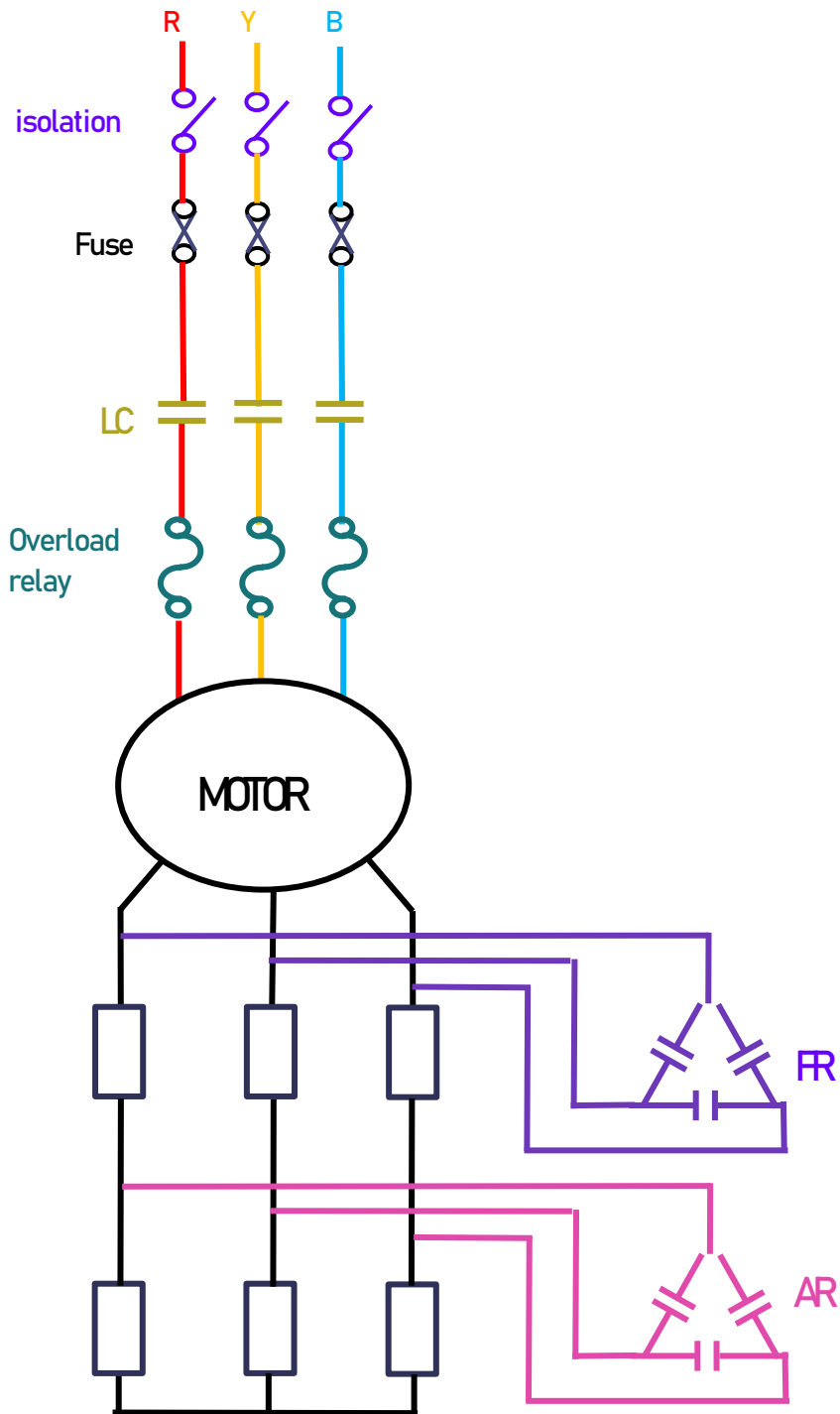

Figure 40: schematic for Rotor Resistance





# QUESTION 21

Figure Q21 is a schematic diagram for Rotor Resistance starter or Liquid Resistance starter operation motor control. Write what will happen when START BUTTON shown in Figure Q21 is pressed and then Start Button is release, after that Stop Button is pressed.

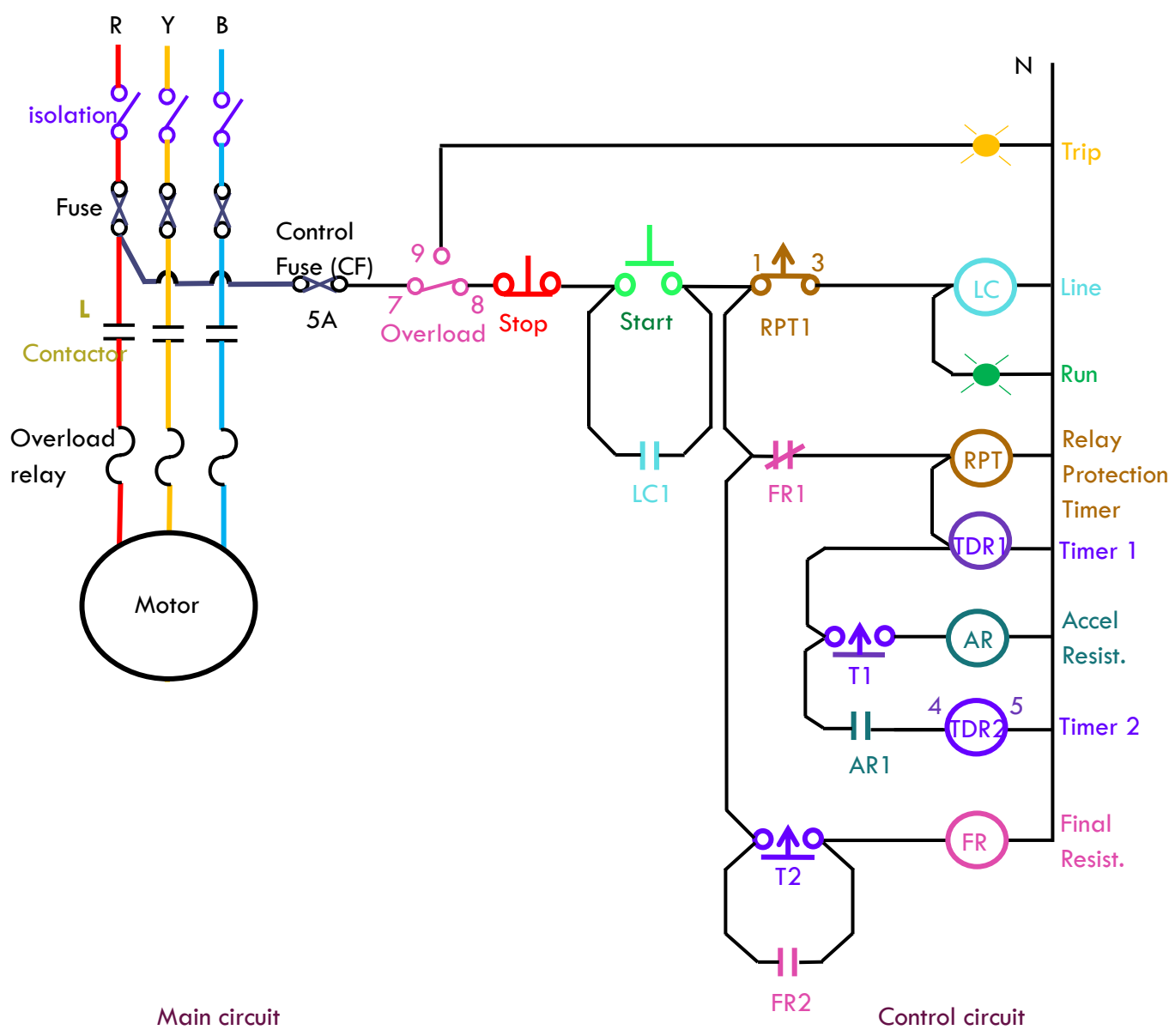

Figure Q21



## SOLUTION 21

### when the Start button is pressed

- When the Start button is pressed the control circuit becomes complete and energizes the holding loop RPT in the closed power circuit.
- It will energize the contactor coil LC caused by magnetic field generate.
- It will cause All contact for to move or change position.
- Normally Open (NO) contact will close position – LC1.
- Indicator lamp Run will turn ON cause by complete circuit.
- at the same time the coils TDR1 and RPT are energized through T1 and FR1.

### when the Start Button is release

- push button start is released LC and RPT still get energy through the RPT1 and holding circuit LC1.
- Where the free loop without voltage (holding loop, LC1) is energized causing the main contact LC and RPT to close.
- The supply flows and energizes the motor,
- at the same time the coils AR are energized through T1.
- when the time that has been set on TDR1 ends, T1 will open causing coil AR to lose energy.
- at the same time the contact of the AR handle is closed, and the control circuit replaces the Start push button
- Normally Open (NO) contact will close position – AR1 and TDR2 energizes.
- at the same time the coils FR are energized through T2 (NO to NC) and holding circuit FR2

# REFERENCE

Herman, S. L. (2016). *Understanding Motor Controls*. Mason, OH, United States: Cengage Learning, Inc.

Chapman, S. J. (2011). *Electric Machinery Fundamentals*. London, United Kingdom: McGraw-Hill Education.

Herman, S. L. (2011). *Electrical Transformers and Rotating Machines*. Clifton Park, United States: Cengage Learning, Inc.

Salam, M. A. (2011). *Fundamentals of Electrical Machines*. Oxford, United Kingdom: Alpha Science International Ltd.

Theraja, B. (2014). *Textbook of Electrical Technology*. New Delhi, India: S Chand & Co Ltd.

AC MOTOR CONTROL

e ISBN 978-629-7643-63-2



9 786297 643632

POLITEKNIK PORT DICKSON  
(online)

FOR ELECTRICAL ENGINEERING

