



BAHAGIAN PEPERIKSAAN DAN PENILAIAN  
JABATAN PENGAJIAN POLITEKNIK  
KEMENTERIAN PENDIDIKAN MALAYSIA

JABATAN KEJURUTERAAN ELEKTRIK

PEPERIKSAAN AKHIR

SESI JUN 2014

EE602: CIRCUIT ANALYSIS

TARIKH : 30 OKTOBER 2014

TEMPOH : 8.30 AM – 10.30 AM ( 2 JAM )

---

Kertas ini mengandungi **SEMBILAN (9)** halaman bercetak.

Bahagian A: Struktur (10 soalan)

Bahagian B: Esei (3 soalan)

Dokumen sokongan yang disertakan : *Laplace Transform Table*

---

**JANGAN BUKA KERTAS SOALAN INI SEHINGGA DIARAHKAN**

(CLO yang tertera hanya sebagai rujukan)



**SECTION A : 40 MARKS****BAHAGIAN A : 40 MARKAH****INSTRUCTION:**

This section consists of **TEN (10)** structured questions. Answer **ALL** questions.

**ARAHAN :**

Bahagian ini mengandungi **SEPULUH (10)** soalan berstruktur. Jawab semua soalan.

CLO1  
C3

**QUESTION 1**

Referring to Figure A1, write the Mesh equations for  $I_1$  and  $I_2$ .

**SOALAN 1**

Merujuk kepada Rajah A1, tuliskan persamaan Mesh bagi  $I_1$  dan  $I_2$ .

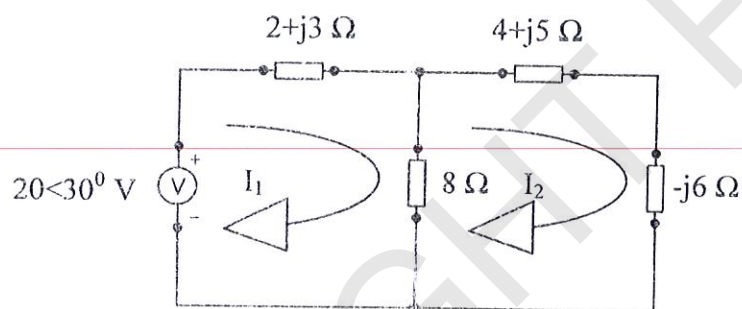

Figure A1/Rajah A1

[4 marks]

[4 markah]

CLO1  
C3

**QUESTION 2**

Calculate the value of  $I_s$  from Figure A2 using the method of source transformation.

**SOALAN 2**

Kirakan nilai  $I_s$  berdasarkan Rajah A2 dengan menggunakan kaedah penukaran punca bekalan.

[4 marks]

[4 markah]

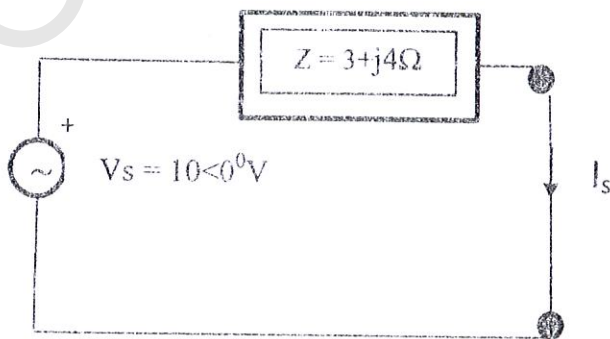

Figure A2/Rajah A2

CLO1

**QUESTION 3**

C1

A Norton equivalent circuit is related to the Thevenin equivalent by the following:

$$R_{Th} = R_{No}$$

$$V_{Th} = I_{No} R_{No}$$

$$I_{No} = V_{Th} / R_{Th}$$

Draw the circuit diagram for Thevenin and Norton equivalent.

**SOALAN 3**

Litar setara Norton dikaitkan dengan litar setara Thevenin adalah seperti berikut:

$$R_{Th} = R_{No}$$

$$V_{Th} = I_{No} R_{No}$$

$$I_{No} = V_{Th} / R_{Th}$$

Lukis gambarajah litar setara Thevenin dan Norton.

[4 marks]

[4 markah]

CLO1

**QUESTION 4**

C3

Referring to Figure 4A, calculate the value of voltage at node A by applying Nodal Analysis method.

**SOALAN 2**

Merujuk kepada Rajah 4A, kirakan nilai voltan pada titik A menggunakan kaedah Analisis Nodal.

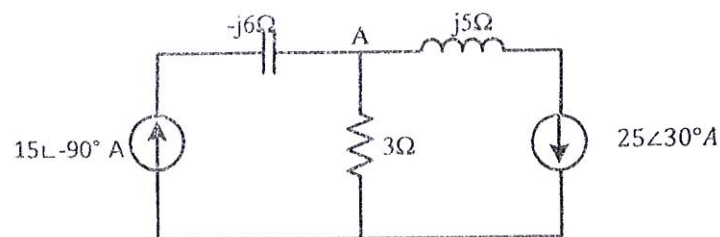

Figure 4A/Rajah 4A

[4 marks]

[4markah]

CLO1  
C3**QUESTION 5**Produce Laplace Transform  $Y(s)$  of first derivatives for the function :

$$y' - 2y = 4, \quad y(0) = 1.$$

**SOALAN 5**Hasilkan pembezaan pertama Jelmaan Laplace  $Y(s)$  bagi fungsi:

$$y' - 2y = 4, \quad y(0) = 1.$$

[4 marks]

[4 markah]

CLO1  
C3**QUESTION 6**Define the Laplace Transform of  $f(t)$  using the definition of the Laplace Transform:

$$f(t) = 5e^{-3t} \sin 4t$$

**SOALAN 6**Tentukan Laplace Transform  $f(t)$  menggunakan takrif Jelmaan Laplace:

$$f(t) = 5e^{-3t} \sin 4t$$

[4marks]

[4 markah]

CLO1  
C3**QUESTION 7**Calculate the circuit impedance in the s-domain,  $Z(s)$  in Figure A7.**SOALAN 7**Kirakan galangan di dalam domain-s,  $Z(s)$  untuk litar dalam Rajah A7.

Figure A7/ Rajah A7

[4marks]

[4 markah]

CLO2  
C1**QUESTION 8**

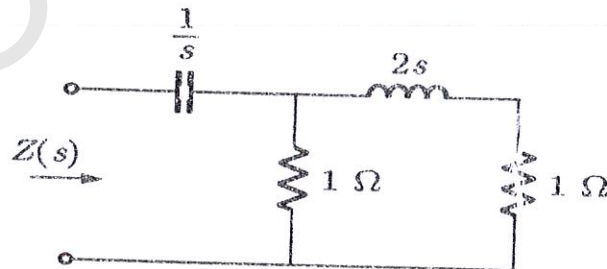
List TWO (2) differences between even and odd waveform.

**SOALAN 8**

Senaraikan DUA (2) perbezaan antara gelombang genap dan gelombang ganjil.

[4 marks]

[4 markah]

CLO2  
C3**QUESTION 9**

Produce Analytic equation for the waveform in Figure A9.

**SOALAN 9**

Hasilkan persamaan analitikal bagi gelombang di Rajah A9.

[4 marks]

[4 markah]

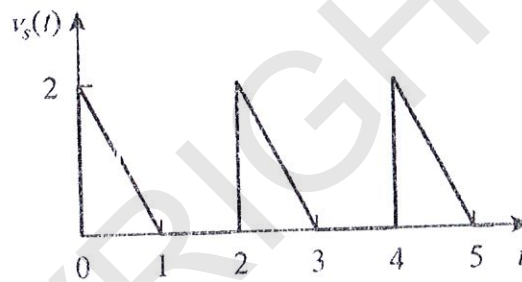

Figure A9/ Rajah A9

CLO2  
C3**QUESTION 10**Construct the Fourier Series equation  $f(t)$  for fourth harmonics if given;

$$a_0 = 0$$

$$a_n = 0$$

$$b_n = \frac{2}{\pi n} [1 - \cos n\pi]$$

**SOALAN 10**Bina persamaan Siri Fourier  $f(t)$  hingga harmonic keempat jika diberi;

$$a_0 = 0$$

$$a_n = 0$$

$$b_n = \frac{2}{\pi n} [1 - \cos n\pi]$$

[4 marks]

[4 markah]

**SECTION B : 60 MARKS**  
**BAHAGIAN B : 60 MARKAH**

**INSTRUCTION:**

This section consists of **THREE (3)** essay questions. Answer **ALL** questions.

**ARAHAN:**

Bahagian ini mengandungi **TIGA (3)** soalan esei. Jawab **SEMUA** soalan.

**QUESTION 1**

**SOALAN 1**

CLO2  
C3

(a) Refer to Figure B1(a), calculate the current to  $Z_3$  by using Thevenin's theorem.

Given  $Z_1 = -j0.5\Omega$ ,  $Z_2 = j0.75\Omega$ ,  $Z_3 = 1k\Omega$  and  $V_s = 50 \angle 0^\circ$

[8 marks]

Berpandukan kepada Rajah B1(a), kirakan nilai arus pada  $Z_3$  dengan menggunakan Teorem Thevenin.

Jika diberi  $Z_1 = -j0.5\Omega$ ,  $Z_2 = j0.75\Omega$ ,  $Z_3 = 1k\Omega$  dan  $V_s = 50 \angle 0^\circ$

[8 markah]

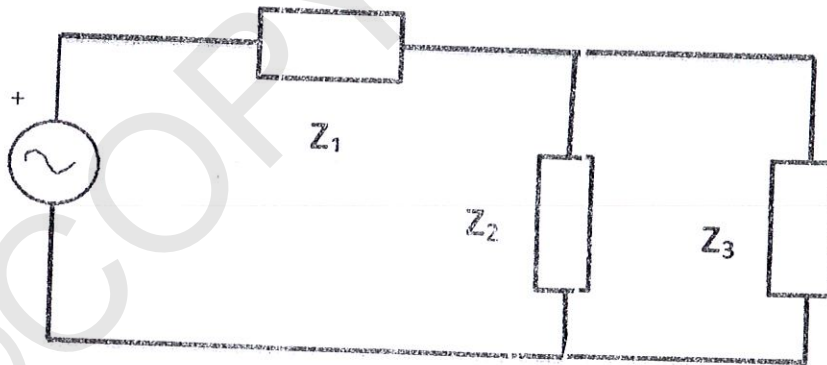

Figure B1 (a) / Rajah B1 (a)

CLO2  
C3(b) Refer to Figure B1(b), calculate the current flow value at  $j5\Omega$  by using Mesh Analysis.

[12 marks]

Berpandukan kepada Rajah B1(b), kirakan nilai arus yang mengalir pada  $j5\Omega$  dengan menggunakan Analisa Mesh.

[12 markah]

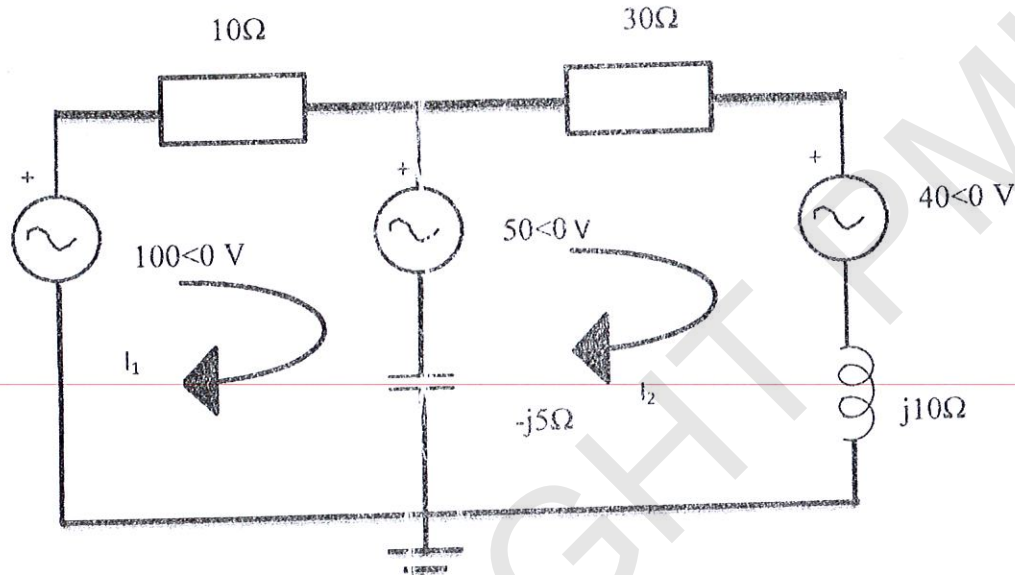

Figure B1(b) / Rajah B1(b)

## QUESTION 2

a. Solve the Laplace Transform of the following function by using Direct Integration Method.

$$f(t) = e^{-5t}$$

[6 marks]

b. Produce the Inverse Laplace Transform of  $F(s)$  given below by using partial fraction.

$$F(s) = \frac{s^3 + 2s + 6i}{s(s+1)^2(s+3)}$$

[14 marks]

CLO3  
C3

## SOALAN 2

- a. Selesaikan Jelmaan Laplace bagi rangkap berikut dengan menggunakan Kaedah Kamilan Terus

$$f(t) = e^{-5t}$$

[6 markah]

- b. Hasilkan Jelmaan Laplace Songsang bagi fungsi  $F(s)$  dengan menggunakan Kaedah pecahan separa.

[14 markah]

$$F(s) = \frac{s^3 + 2s + 6}{s(s+1)^2(s+3)}$$

## QUESTION 3

Referring to Figure B3 (c) below :

Merujuk kepada Rajah B3(c) di bawah :

- a. Write an analytical equation for the waveform  $f(t)$

Tuliskan persamaan analitik bagi fungsi  $f(t)$

[3 Marks]

[3 Markah]

- b. Calculate the Fourier Series coefficients of  $a_0$ ,  $a_n$  and  $b_n$ .

Kirakan pekali Siri Fourier  $a_0$ ,  $a_n$  dan  $b_n$ .

[12 Marks]

[12 Markah]

- c. Produce the Fourier Series equation  $f(t)$  for  $n = 1$  to 3

Dapatkan persamaan Siri Fourier  $f(t)$  bagi  $n = 1$  hingga 3

[5 Marks]

[5Markah]

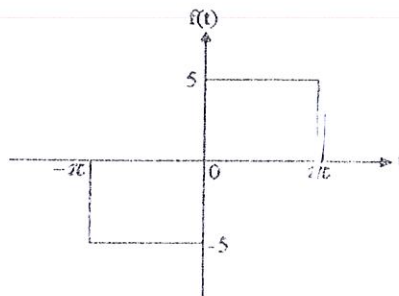

Figure B3(c) / Rajah B3(c)

## SOALAN TAMAT



©COPYRIGHT PMU



	$\mathcal{L}^{-1}\{F(s)\} = f(t)$	$F(s) = \mathcal{L}\{f(t)\}$
i.	1	$\frac{1}{s}$
ii.	k	$\frac{k}{s}$
iii.	$e^{at}$	$\frac{1}{s-a}$
iv.	$\sin at$	$\frac{a}{s^2 + a^2}$
v.	$\cos at$	$\frac{s}{s^2 + a^2}$
vi.	t	$\frac{1}{s^2}$
vii.	$t^2$	$\frac{2!}{s^3}$
viii.	$t^n$	$\frac{n!}{s^{n+1}}$
ix.	$\sinh at$	$\frac{a}{s^2 - a^2}$
x.	$\cosh at$	$\frac{s}{s^2 - a^2}$
xi.	$e^{at} t^n$	$\frac{n!}{(s-a)^{n+1}}$
xii.	$e^{at} \sin \omega t$	$\frac{\omega}{(s-a)^2 + \omega^2}$
xiii.	$e^{at} \cos \omega t$	$\frac{s-a}{(s-a)^2 + \omega^2}$
xiv.	$e^{at} \sinh \omega t$	$\frac{\omega}{(s-a)^2 - \omega^2}$
xv.	$e^{at} \cosh \omega t$	$\frac{s-a}{(s-a)^2 - \omega^2}$

©COPYRIGHT PMU