



ELECTRICAL POWER GENERATION

Yuzrina Md Yunus
Safira Din
Shazila Idayu Manja

ELECTRICAL

POWER GENERATION



First Edition

September 2023

© Perpustakaan Negara Malaysia, 2023

All rights reserved. No part of this publication may be reproduced, stored in a retrieval system, or transmitted in any form or by any means, electronic, mechanical, photocopying, recording or otherwise, without the prior permission of Ketua Pengarah Perpustakaan Negara Malaysia.

EDITOR:

Rahayu Jonit

AUTHOR:

Yuzrina binti Md Yunus

Safira binti Din

Shazila Idayu binti Manja

PUBLISHED BY:

Politeknik Port Dickson

KM 14, Jalan Pantai

Si Rusa

71050 Port Dickson

Negeri Sembilan

Tel : 06-6622023 (Librarian)

06-6622048 (Counter)

E-mail : suzilawati@polipd.edu.my



Cataloguing-in-Publication Data

Perpustakaan Negara Malaysia

A catalogue record for this book is available
from the National Library of Malaysia

eISBN 978-967-2897-95-8

ACKNOWLEDGEMENT

PATRON

Mej (K) Dr. Ishak bin Mohamad
Director, Politeknik Port Dickson

ADVISORS

Abdul Rahim bin Ibrahim
Deputy Director (Academic), Politeknik Port Dickson
Abdul Razak bin Ismail
Head of Electrical Engineering Department, Politeknik Port Dickson

EDITOR

Rahayu binti Jonit
Electrical Engineering Department, Politeknik Port Dickson

FACILITATORS

Che Azlina binti Che Norohoseni
Zuliana binti Zainal Abidin
Yuzrina binti Md Yunus

WRITERS

Yuzrina binti Md Yunus
Safira binti Din
Shazila Idayu binti Manja

We would like to convey our utmost gratitude to the Department of Polytechnic and Community College Education particularly the E-learning and Instructional Division (BIPD) for funding our e-book project.

We hereby declare that this module is our original work. To the best of our knowledge it contains no materials previously written or published by another person. However, if there is any, due acknowledgement and credit are mentioned accordingly in the e-book.

PREFACE

The goal of the Electrical Power Generation book is to serve as a resource for electrical engineering students. It is intended to cover a broad range of electrical power generation in power systems from both renewable and non-renewable sources.

This book is on electrical generation in power system theory. It focuses on power system electric power generation concepts, types of energy, operational and block diagram of power plant, also advantage and disadvantage of renewable energy and non-renewable energy.

The provision of tutorial questions in order to increase the reader's value of the book and encourage a clear knowledge of the material.

This book includes three authors from the DEG and DEQ programs who are lecturers, prominent authorities in their fields, and have extensive understanding of their subjects.

ABSTRACT

The purpose of Electrical Power Generation book is to provide a reference that is useful for electrical engineering students. The concept of this technical ebook used is interactive in the form of infographics elements to attract the interest of the students and certain groups to read this ebook.

The ebook covers a wide range of topics related to electrical power generation in power systems. It provides a thorough understanding of both renewable and non-renewable sources of energy. The three main topics covered in the ebook are:

- 1. Electrical Generation in Power Systems:** This section lays the foundation for understanding power generation in power systems and introduces key concepts and principles.
- 2. Electrical Generation from Renewable Sources:** This section explores various renewable energy, including solar energy, wind energy, hydro energy, biomass energy, biofuel energy, and geothermal energy.
- 3. Electrical Generation from Non-Renewable Sources :** This section focuses on non-renewable energy such as fossil fuels like coal, natural gas, and nuclear energy.

Each topic in this book describes a summary note in addition to some examples that are described in detail for the understanding of the students. The presentation is example questions to enhance the value of the book to the reader and foster a clear understanding of the material and each question posed clearly describes the answer to that question.

TABLE OF CONTENTS

Preface	i
Abstract	ii

01

Electrical Generation in Power System

1.1 Concept of Power System	1
1.2 Concept of Renewable Energy	3
1.3 Concept of Non-Renewable Energy	4
1.4 Advantages & Disadvantages of Renewable Energy	5
1.5 Advantages & Disadvantages of Non-Renewable Energy	6
1.6 Importance of Renewable Energy	7
Question	8

02

Electrical Generation from Renewable Sources

2.1 Source of Renewable Energy	9
2.2 Solar Energy	10
2.3 Wind Energy	16
2.4 Hydro Energy	20
2.5 Biomass Energy	23
2.6 Biofuel Energy	27
2.7 Geothermal Energy	31
Question	36

03

Electrical Generation from Non-Renewable Sources

3.1 Source of Non-Renewable Energy	37
3.2 Fuel	38
3.3 Coal	42
3.4 Natural gas	46
3.5 Nuclear	50
Question	55

Answer	56
References	57





CHAPTER

1

ELECTRICAL GENERATION IN POWER SYSTEM

1.1

CONCEPT OF THE POWER SYSTEM



Power system is a network which consists **generation, distribution and transmission** system. It uses the form of energy (like coal and diesel) and converts it into electrical energy.

COMPONENT OF POWER SYSTEM

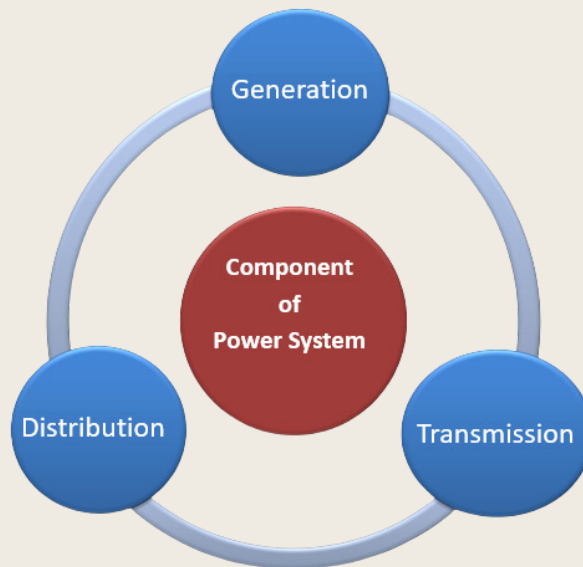

Figure 1.1 : Component of Power Systems

- Electricity is generated at central power stations and then transferred to loads (i.e, Domestic, Commercial and Industrial) through the transmission and distribution system.
- A combination of all these systems is collectively known as an **Electric Power System**.
- **Generating stations, transmission lines and distribution systems** are the main components of an **Electrical Power System**

DIAGRAM OF POWER SYSTEM

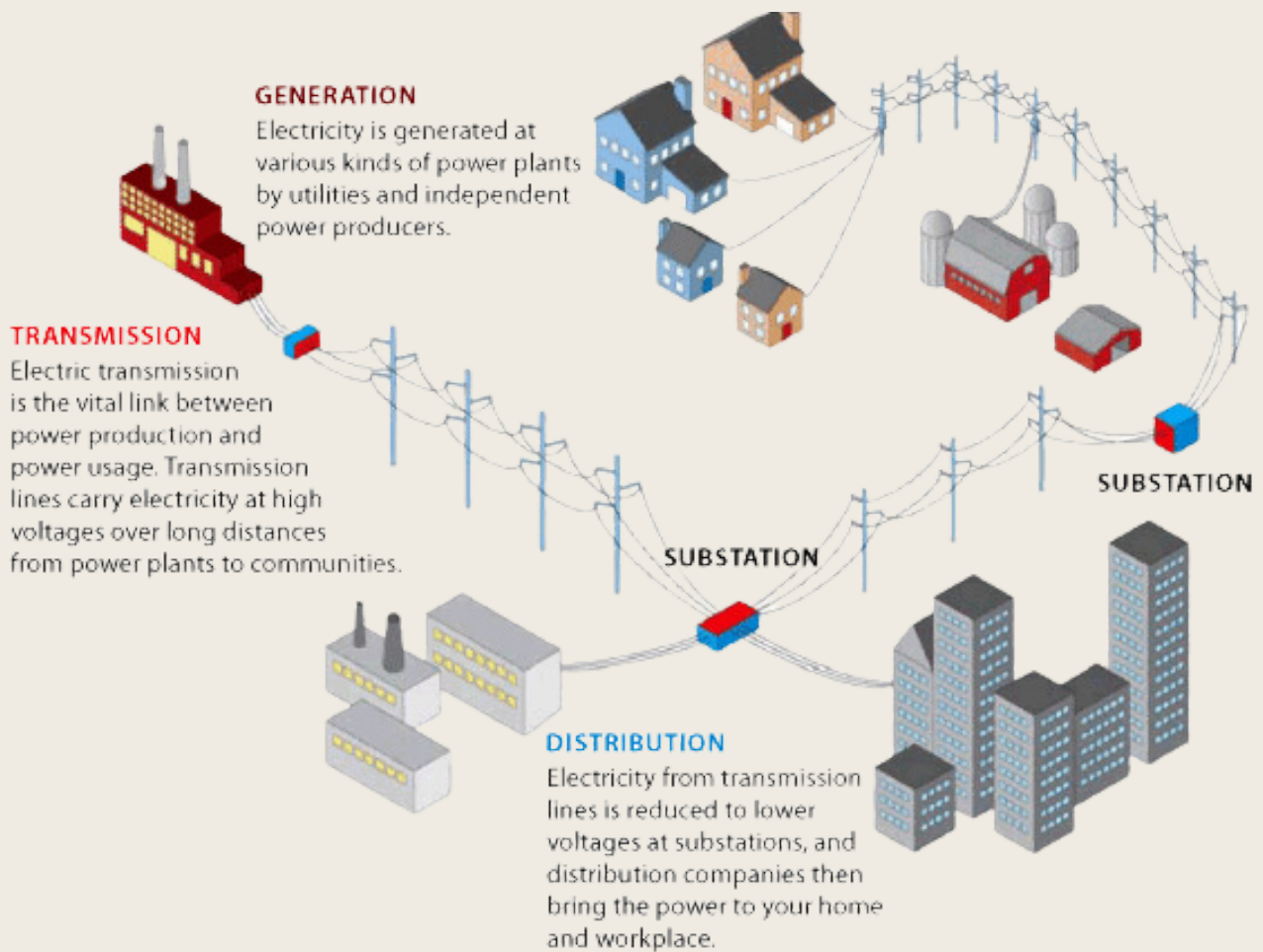

Figure 1.2 : Diagram of Power Systems



Why do we use 3-phase AC Systems?

3-phase AC systems are one way to transfer as much power as possible over long distances for distribution.

1.2

CONCEPT OF RENEWABLE ENERGY

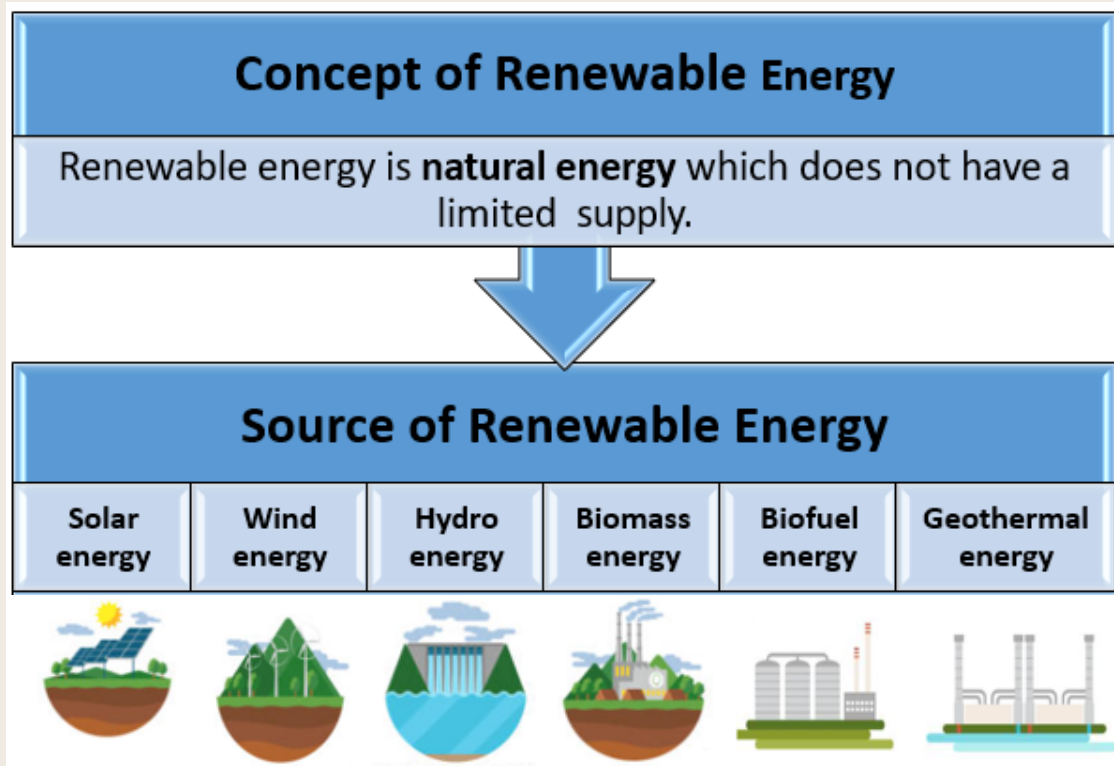

Concept of Renewable Energy

- Renewable energy is natural energy which does not have a limited supply.
- Renewable energy can be used repeatedly, and will never run out. Energy that comes from resources which are continually replenished on a human timescale
- Energy is generated from sunlight, ecology, wind, rain, tides, waves, geothermal, biofuel, hydrogen etc.
- They are also known as **non-conventional** sources of energy.
- They are environment friendly and pollution-free.
- The effectiveness of renewable energy depends upon the resource being used. Some renewable sources are more readily available and effective than others, while some, such as geothermal are of great use in some locations and not in others due to accessibility

1.3

CONCEPT OF NON-RENEWABLE ENERGY

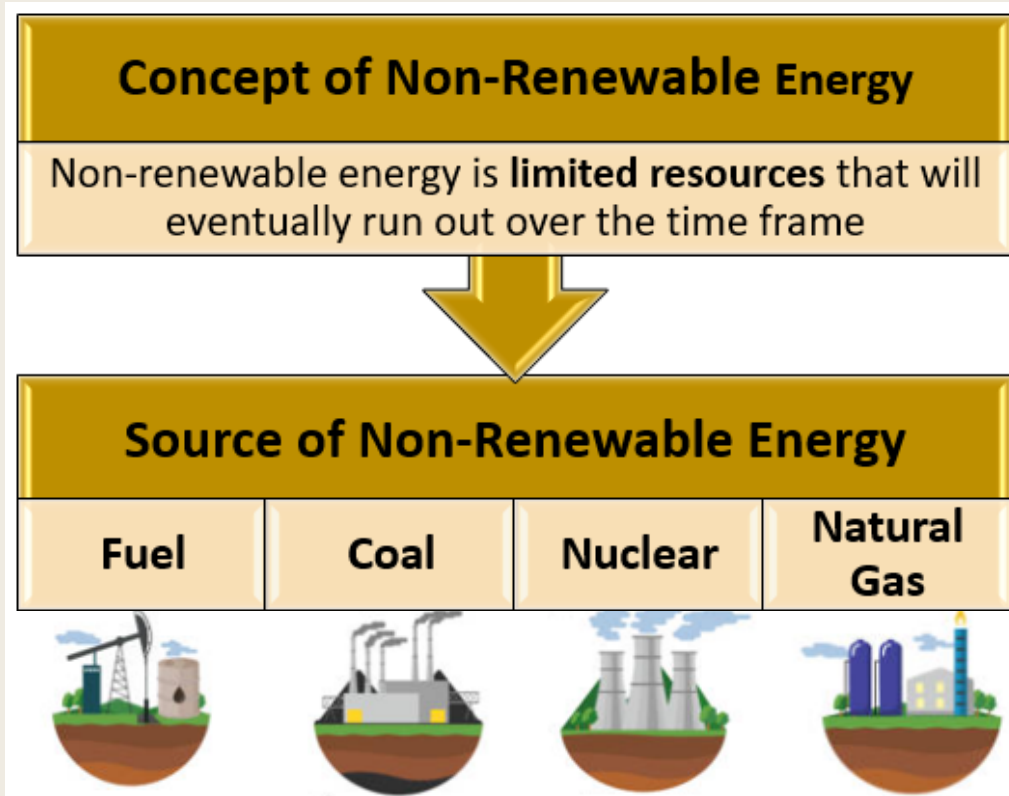

Concept of Non-Renewable Energy

- Non-renewable energy is energy derived from finite resources that are not replaced quickly enough to keep up with the speed of consumption.
- Non-renewable energy sources will not be replenished in our lifetime, or, more accurately, many human lifetimes.
- Most non-renewable energy sources are fossil fuels such as petroleum and crude oil, coal, and natural gas, but nuclear fuel, mainly used to produce electricity, is also generally classified as non-renewable.
- These also known as **conventional** sources of energy.
- Coal, fuel, nuclear energy, petroleum, natural gas are some examples.

1.4

**ADVANTAGES & DISADVANTAGES OF
RENEWABLE ENERGY****ADVANTAGES**

- ➔ Sustainable energy sources (fuel never run out)
- ➔ Facilities generally require less maintenance than traditional generators
- ➔ Little or no waste carbon emission product
- ➔ Economic benefits (tourist-suburban etc.)
- ➔ Cause no harm to life to exist on earth

DISADVANTAGES

- ➔ Limited to geographical and resources. Reliability of availability fuel supply (depending upon ecological nature)
- ➔ Unpredictable and inconsistent
- ➔ New technology. Large capital cost
- ➔ Difficult to generate large quantities of electricity

1.5

**ADVANTAGES & DISADVANTAGES OF
NON-RENEWABLE ENERGY****ADVANTAGES**

- ➔ Easy to use and quite easy to store
- ➔ It is affordable and more compatible
- ➔ High energy density
- ➔ Can be efficiently converted to the type of energy required

DISADVANTAGES

- ➔ Causes pollution and also, they can cause respiratory problems in humans
- ➔ Burning fossil fuels is harmful to the environment due to making pollution of the air, water as well as land.
- ➔ Responsible for acid rain and produces greenhouse gases



How are non-renewable & renewable resources formed?

Non-Renewable Energy

- Non-renewable energy is ancient and comes from the fossilized remains of animals and plants.
- Non-renewable energy takes an incredible amount of time to form, so it is not considered sustainable or renewable for the long term.

Renewable Energy

- Renewable energy sources come from nature too, but they are accessible at nearly all times worldwide.
- In theory, we can obtain and replenish renewable resources every day. Every time the wind blows, the sun shines and water runs through a river, We can harness that energy to make electricity.

1.6

IMPORTANCE OF RENEWABLE ENERGY

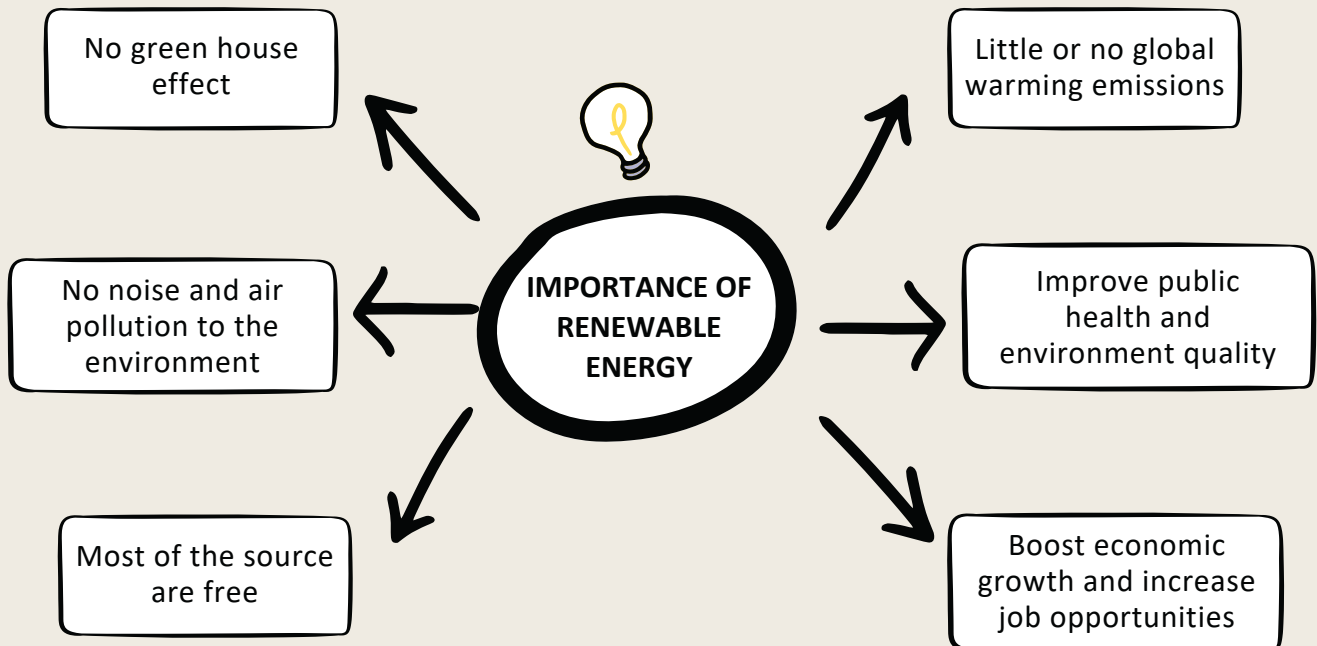

Differences between Clean Energy and Green Energy

Clean Energy

Clean energy is energy that comes from renewable, zero emission sources that do not pollute the atmosphere when used, as well as energy saved by energy efficiency measures.

Green Energy

Green energy is any energy type that is generated from natural resources, such as sunlight, wind or water. It often comes from renewable energy sources although there are some differences between renewable and green energy, which we will explore, below

QUESTION

- 1 List **THREE (3)** component in power system.

- 2 List the sources of renewable energy.

- 3 Explain the concept of renewable energy.

- 4 Explain the concept of non-renewable energy.

- 5 Explain the advantages and disadvantages of renewable energy.

- 6 State **FOUR (4)** importance of renewable energy.



CHAPTER 2

ELECTRICAL GENERATION FROM RENEWABLE SOURCES

2.1

SOURCES OF RENEWABLE ENERGY

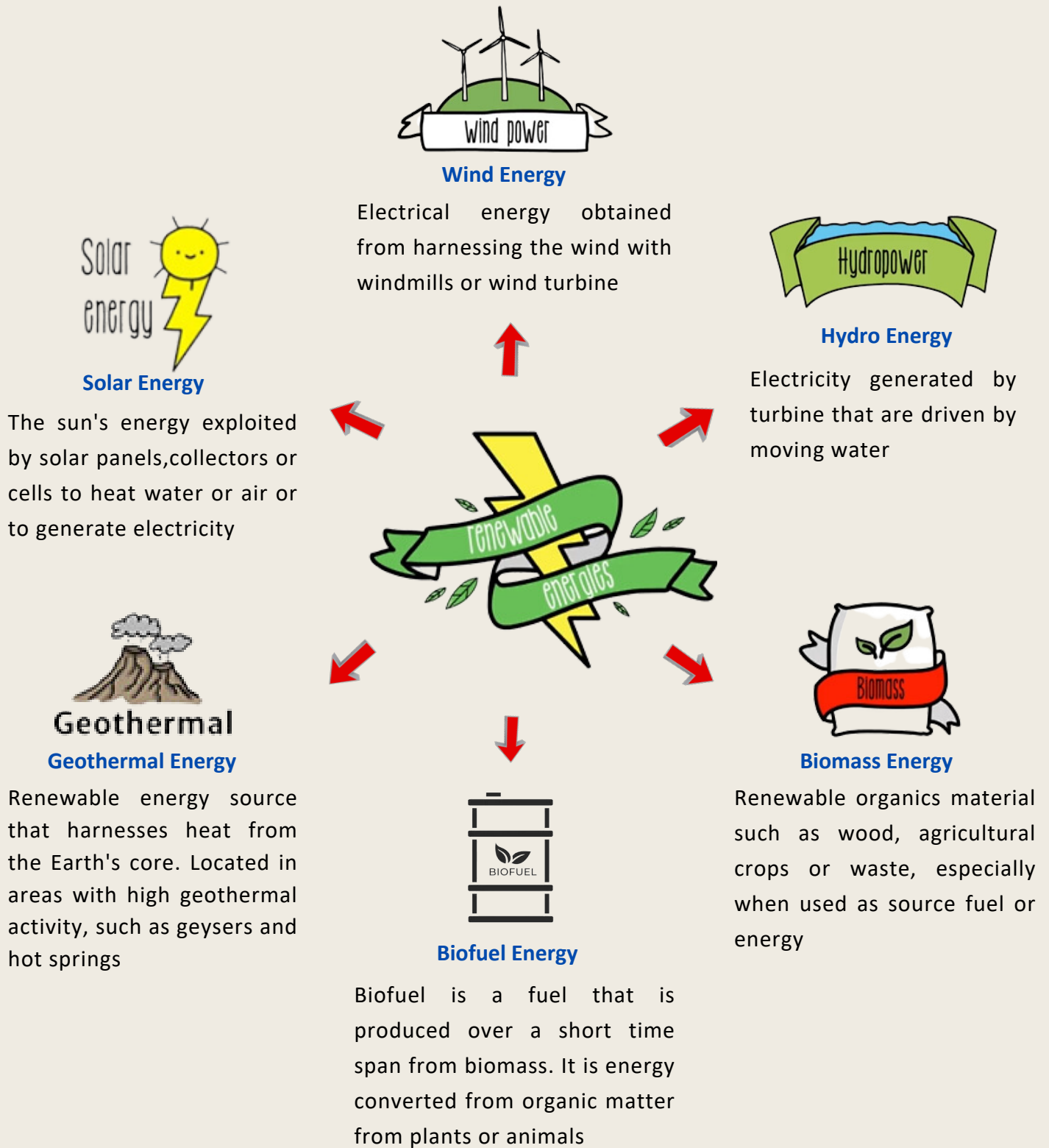
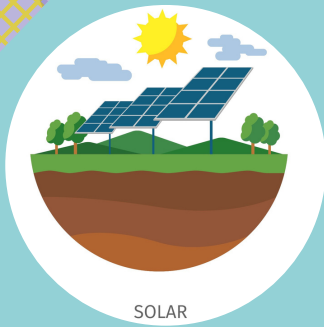

Figure 2.1 : Sources of renewable energy

INTRODUCTION

2.2

SOLAR ENERGY



Solar energy or solar power is the conversion of energy from sunlight into electricity, either directly using photovoltaics (PV) or indirectly using concentrated solar power.

OPERATION PROCESS OF PV SOLAR POWER PLANT

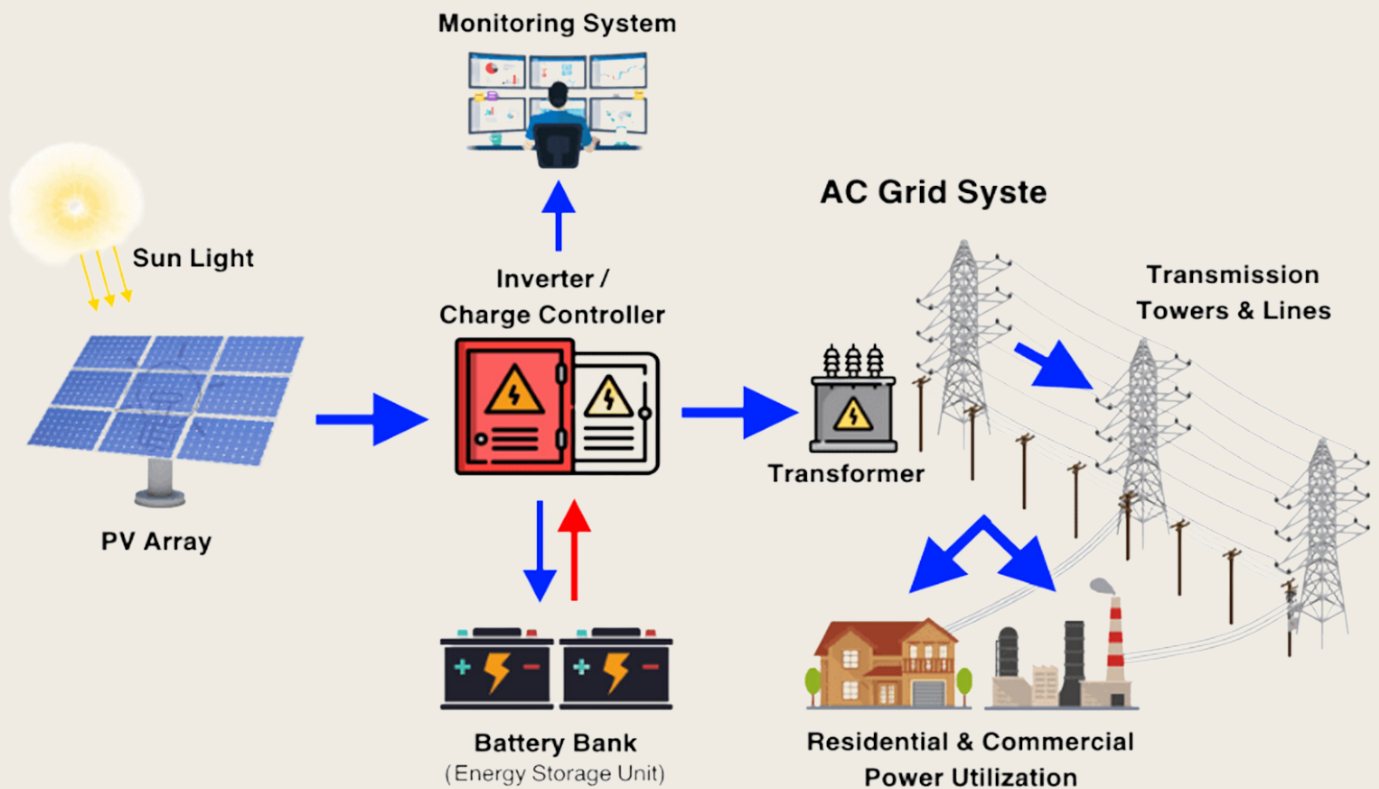
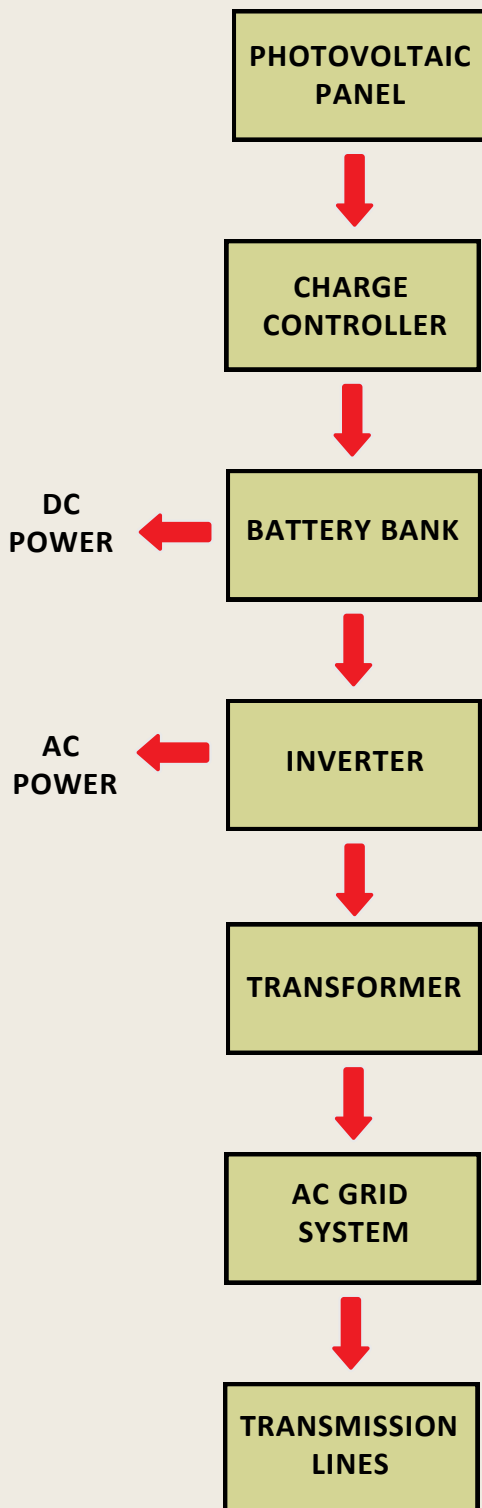

Figure 2.2 : Operation process of PV Solar Power Plant

OPERATIONAL OF PHOTOVOLTAIC (PV) SOLAR POWER PLANT



PV panel is to capture light, or more specifically, the photons from the sun and convert their energy into useful electricity through a process called the photovoltaic effect

To control the charging and discharging of the battery. The **charge controller** is used to avoid the overcharging of the battery.

Battery bank are used to store electrical energy generated by the solar power plants. The capacity of a battery is that how much amount of electrical power it can store

Inverter is to convert DC output power into AC power

Transformer is to increase the voltage to the system bus voltage to transmit power to the system

Also known as a “**grid-tied**”, or “**on-grid**” solar system, the PV solar panels or array are electrically connected or “**tied**” to the local mains electricity grid which feeds electrical energy back into the grid.

Transmission line carry electric energy from one point to another in an electric power system

Figure 2.3 : Operational of Photovoltaic (PV) Solar Power Plant

TYPES OF SOLAR POWER

1 Photovoltaic Solar Energy Plant

- Photovoltaic cells will capture the energy which is generated from the sun and get it converted into electricity
- The process of energy conversion is clean and simple and it does not involve injecting any kind of smoke or harmful chemicals into the atmosphere



Figure 2.4 : Photovoltaic Solar Energy Plant

2 Solar Thermal Energy Plant

- A solar thermal energy plant will be used for creating solar generated heaters which can be used for heating water and also as an indoor heating system.
- Thermal cells will be used to capture the energy which has been generated by the sun and then convert it into heat energy.

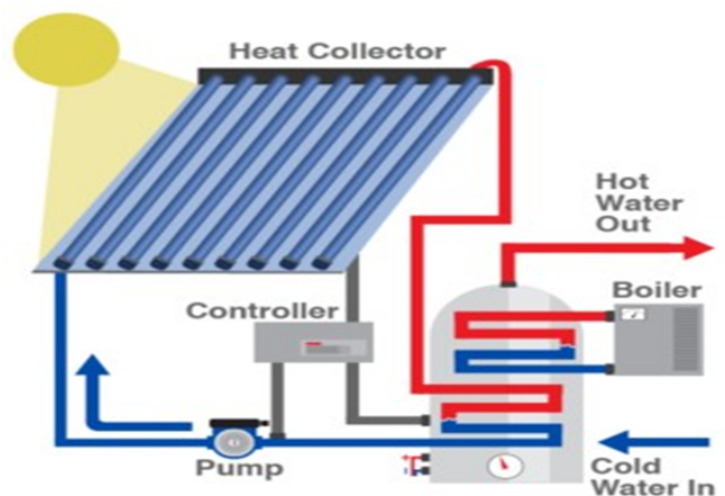

Figure 2.5 : Solar Thermal Energy Plant

3 Concentrating Solar Power (CSP) Plant

There are four types of CSP technologies :

1. **Linear fresnel** - a large number of collectors are set out in rows. The mirrors are laid flat on the ground and reflect the sun on to the receiver pipe above. Fresnel can integrate storage in power block or generate steam directly.
2. **Power tower** - the system use mirror called heliostats that track the sun and focus its energy onto a receiver at the top of a tower. A fluid (often molten salts) is heated inside the receiver and is used to generate steam, which drive a turbine generator.
3. **Parabolic dish** - a parabolic-shaped dish acts a concentrator that reflects solar energy onto a receiver mounted on a structure with a tracking system that follows the sun. The collected heat is then generated by a heat engine. The dish can attain very high temperatures, which makes the system potentially well-suited for use in solar reactors.
4. **Parabolic trough** - Solar energy is concentrated by curved, trough-shaped reflectors, which are focused onto a receiver pipe. The pipe usually contains thermal oil, which is heated and then used in the thermal power block to generate electricity in a steam generator.

1 LINEAR FRESNEL REFLECTOR

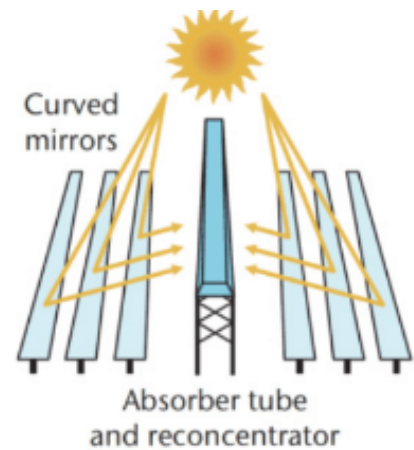

2 POWER TOWER

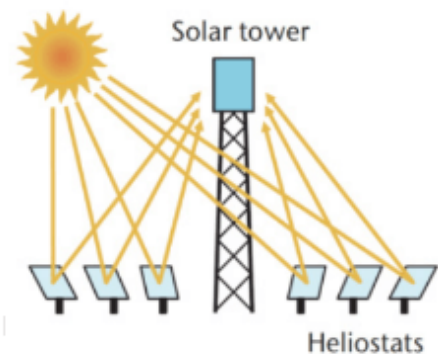

3 PARABOLIC DISH



4 PARABOLIC TROUGH

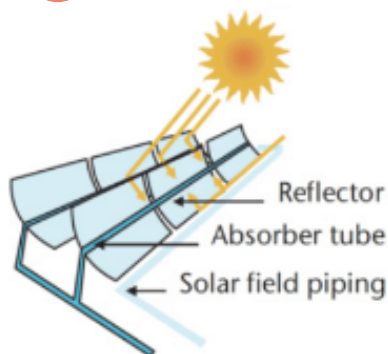
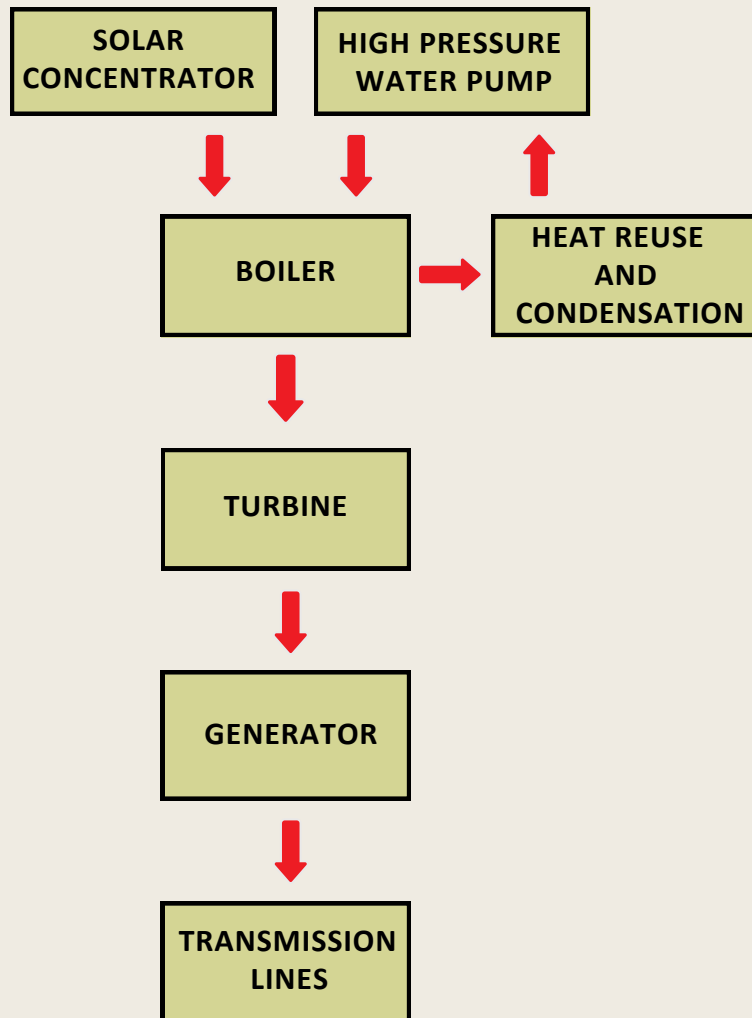

Figure 2.6 : Types of Concentrating Solar Power

OPERATIONAL OF CONCENTRATED SOLAR POWER (CSP) PLANT



Concentrating solar power (CSP) plant use mirrors configuration that concentrates the sun's solar energy onto a receiver.

The energy from the concentrated sunlight heats a high temperature fluid in the receiver (**boiler**).

The heat is also known as thermal energy then converted into steam to drive a **turbine** or power an engine to generate electricity use **generator**.

CSP plants can use thermal energy storage systems to store the power until it's needed, day or night.

Figure 2.7 : Operational of Concentrated Solar Power Plant

ADVANTAGES & DISADVANTAGES OF SOLAR POWER PLANT**ADVANTAGES**

- ➔ Solar power systems do not require a lot of maintenance. Residential solar panels usually only require cleaning a couple of times a year
- ➔ Solar energy is sustainable because there is no way we can over-consume
- ➔ Solar energy is available all over the world
- ➔ Harnessing solar energy does generally not cause pollution

DISADVANTAGES

- ➔ Energy storage systems such as batteries will help smoothen out demand and load, but these technologies are expensive
- ➔ Solar energy is an intermittent energy source. Access to sunlight is limited at certain times (e.g. morning and night)
- ➔ Require space to install solar panels
- ➔ The upfront costs of a solar panel system is high.

*Types of Photovoltaic Panel*

There are three main types of PV (photovoltaic) panels:

- Monocrystalline panels are made from a single crystal of silicon and are known for their high efficiency and sleek appearance.
- Polycrystalline panels are made from multiple silicon crystals and are slightly less efficient but more affordable.
- Thin-film panels use a much thinner layer of semiconductor material and are often flexible, making them useful for certain applications.

Each type of panel has its own advantages and disadvantages, so it's important to research and choose the best option for your specific needs.

INTRODUCTION

2.3

WIND ENERGY

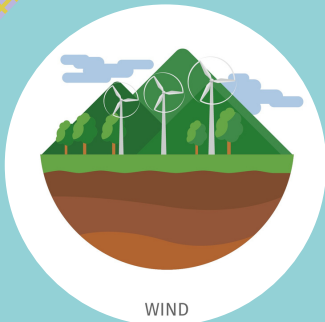

Wind energy is a renewable source of energy that is generated by wind turbines. These turbines convert the kinetic energy of wind into electrical energy. Wind energy is a clean and sustainable source of energy that produces no greenhouse gas emissions, unlike fossil fuels.

DIAGRAM OF WIND POWER GENERATION PLANT

Wind turbines can be installed onshore or offshore, and their size can range from small turbines for individual households to large wind farms that can power entire cities. Wind energy has the potential to play a significant role in reducing our dependence on fossil fuels and mitigating the effects of climate change.

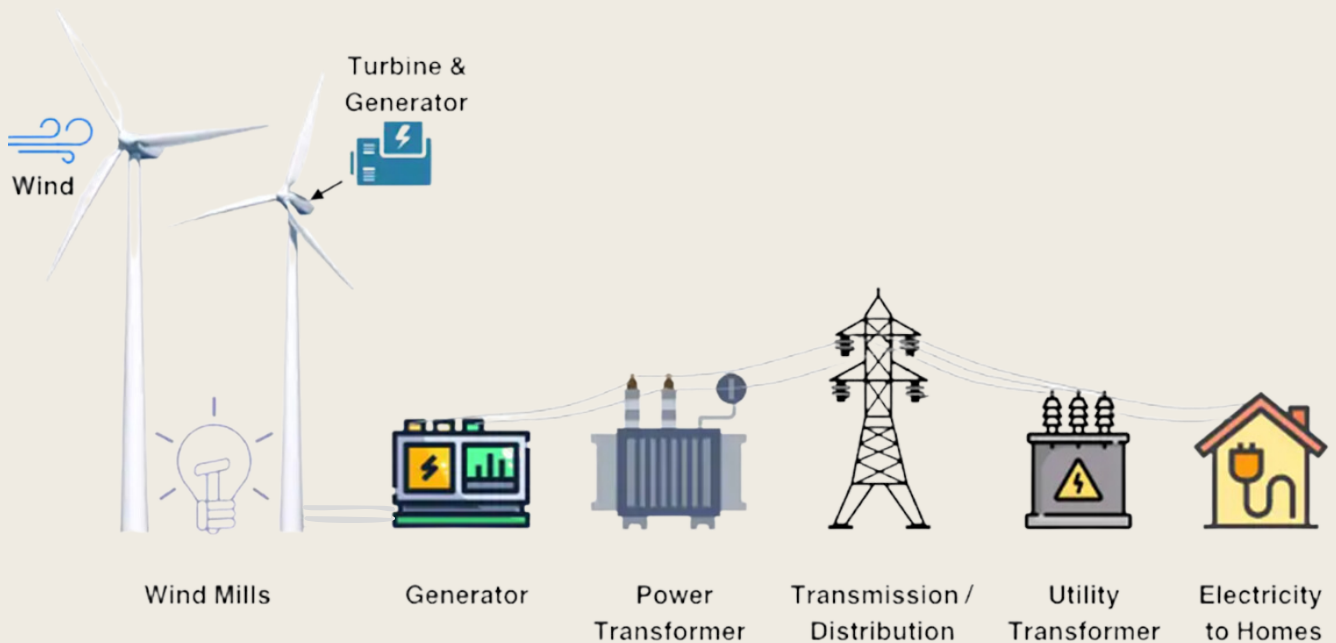

Figure 2.8 : Diagram of Wind Power Plant

OPERATIONAL OF WIND POWER GENERATION PLANT

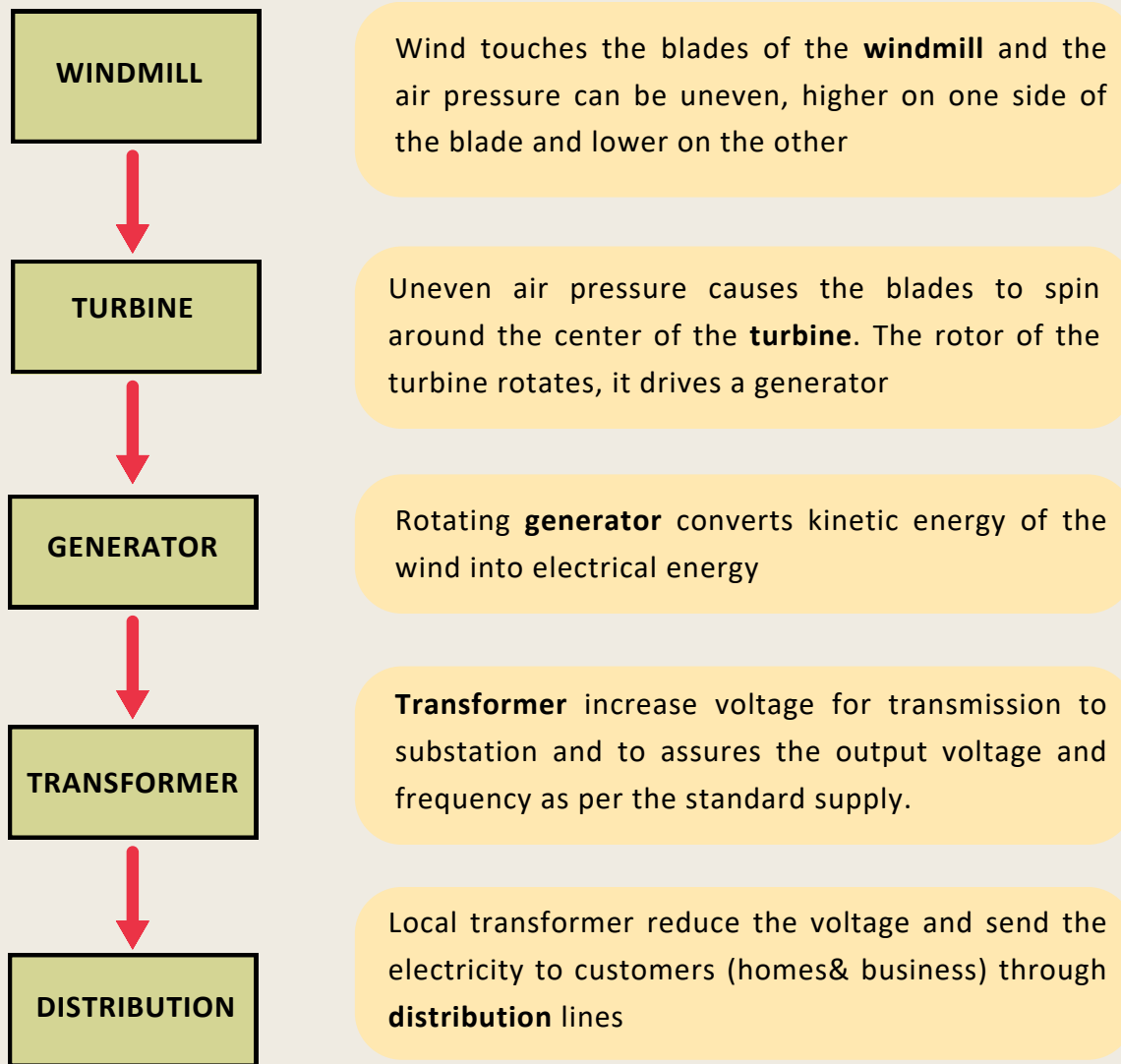

Figure 2.9 : Operational of Wind Power Generation Plant

TYPES OF WIND TURBINE

1 Horizontal-axis Wind Turbines
(HAWT)

Figure 2.10 : Horizontal-axis wind turbines

Horizontal-axis turbines have blades like airplane propellers, and they commonly have three blades

2 Vertical-axis Wind Turbines
(VAWT)

Figure 2.11 : Vertical-axis wind turbines

Vertical-axis turbines have blades that are attached to the top and the bottom of a vertical rotor

*Wind Turbine*

- The length of the blades is the biggest factor in determining the amount of electricity a wind turbine can generate
- Small wind turbines that can power a single home may have an electricity generating capacity of 10 kilowatts (kW)
- Largest wind turbines in operation have electricity generating capacities of up to 10,000 kilowatts (kW) and larger turbines are in development

ADVANTAGES & DISADVANTAGES**1****Horizontal-axis Wind Turbines (HAWT)****ADVANTAGES**

- ➔ Higher efficiency
- ➔ Ability to turn the blades
- ➔ Lower cost-to-power ratio

DISADVANTAGES

- ➔ Generator and gearbox should be mounted on a tower, thus restricting servicing,
- ➔ More complex design required due to the need for yaw or tail drive

2**Vertical-axis Wind Turbines (VAWT)****ADVANTAGES**

- ➔ Easy maintenance for ground mounted generator and gearbox
- ➔ Receive wind from any direction (no yaw control required)
- ➔ Simple blade design and low cost of fabrication

DISADVANTAGES

- ➔ Not self starting, thus, require generator to run in motor mode at start
- ➔ Lower efficiency (the blades lose energy as they turn out of the wind)
- ➔ Difficulty in controlling blade over-speed
- ➔ Oscillatory component in the aerodynamic torque is high.

INTRODUCTION

2.4

HYDRO ENERGY

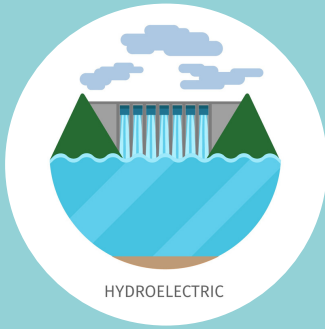

Hydro energy is created in a process that starts when water flows through a dam (the dam can be opened or closed to varying degrees to control water flow and to produce the amount of electricity needed, based on demand)

HYDRO POWER PLANT

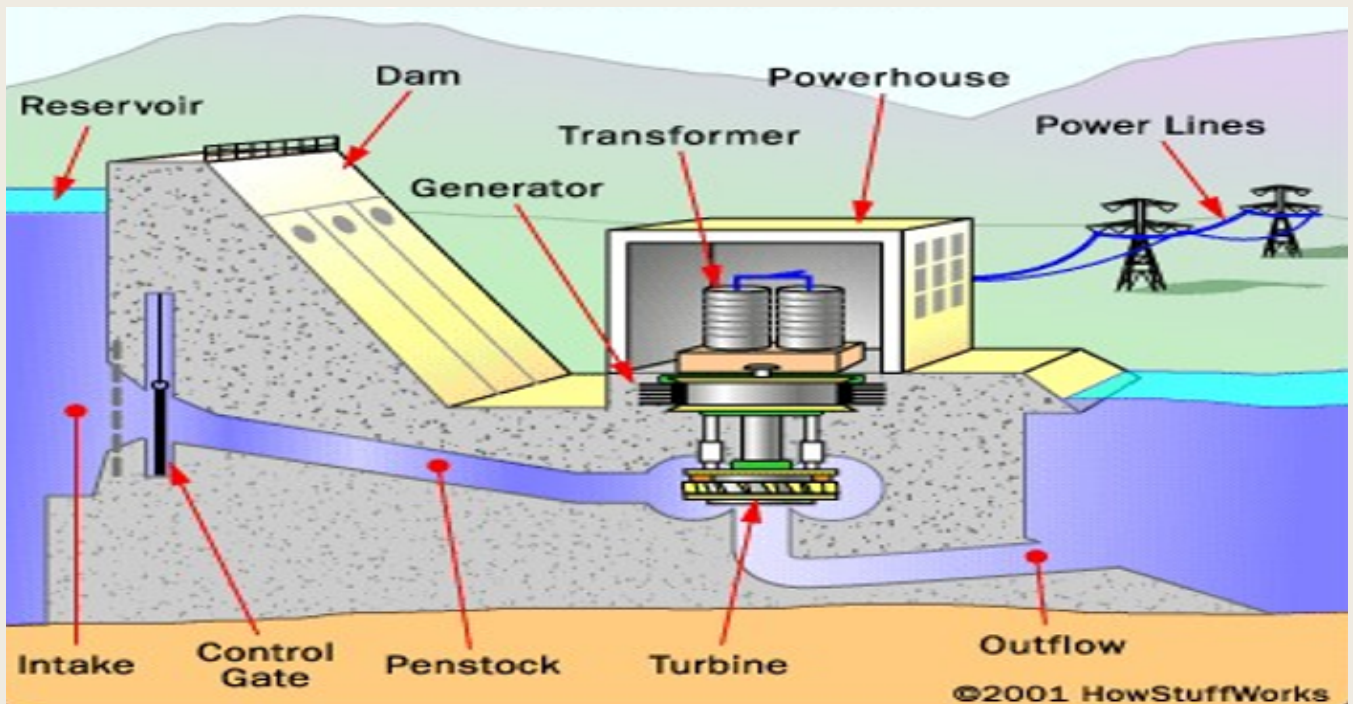

Figure 2.12 : Diagram of Hydro Power Plant

OPERATIONAL OF HYDRO POWER PLANT

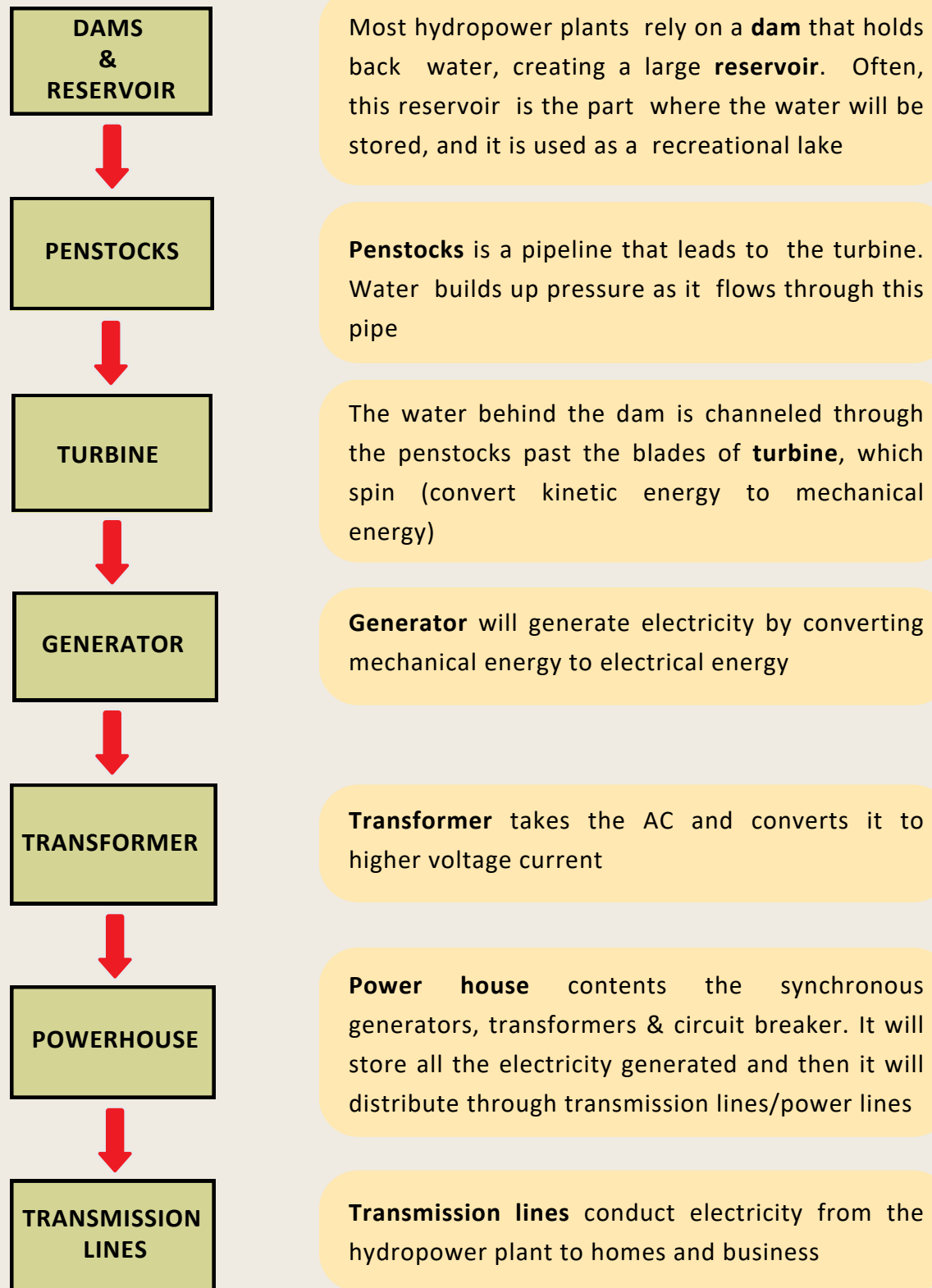

Figure 2.13 : Operational of Hydro Power Plant

ADVANTAGES & DISADVANTAGES OF HYDRO POWER PLANT**ADVANTAGES**

- ➔ Water is a renewable resource that is accessible year-round
- ➔ The operating and maintenance costs are lower than those of other power plants
- ➔ Fuel is not required
- ➔ The number of people required to monitor the plant's operation is low

DISADVANTAGES

- ➔ The expense of building a dam is substantial
- ➔ The amount of land required for setup is substantial
- ➔ Harmful for aquatic life
- ➔ requires high cost of transmission lines as the plant is located in hilly areas which are quite away from the consumers



Types of Hydro Power Plant

Hydro power plants generate electricity by harnessing the power of falling water. There are several types of hydro power plants:

- Conventional hydroelectric plants use dams to create a reservoir of water, which is then released through turbines to generate electricity.
- Pumped-storage hydroelectric plants use excess electricity to pump water from a lower reservoir to a higher reservoir, which is then released to generate electricity when demand is high.
- Run-of-river hydroelectric plants do not require a reservoir, instead relying on the natural flow of a river to turn turbines and generate electricity.

Each type of hydro power plant has its own advantages and disadvantages, and can be chosen based on the specific conditions of the site.

INTRODUCTION

2.5

BIOMASS ENERGY

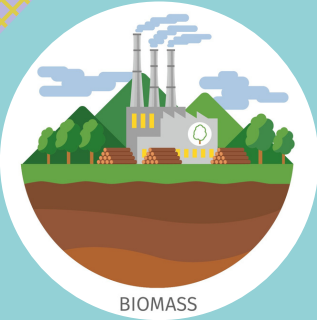

Biomass energy is a renewable energy source that is produced by burning organic matter such as wood, crops, and agricultural waste. Biomass energy can be used to generate electricity, heat homes and buildings, and fuel vehicles. It is a promising alternative to fossil fuels because it produces fewer greenhouse gas emissions and reduces our reliance on non-renewable energy sources.

TYPES OF BIOMASS SOURCES



ARRICULTURAL CROPS & RESIDUES

INDUSTRIAL RESIDUES

FORESTRY CROPS & RESIDUES

SEWAGE

ANIMAL RESIDUES

MUNICIPAL SOLID WASTE

Figure 2.14 : Various sources of biomass

BIOMASS POWER GENERATION PLANT

Biomass power plants typically use a boiler to convert organic material into steam, which is then used to turn a turbine and generate electricity. The leftover ash is often used as a fertilizer, making biomass power generation a sustainable and environmentally friendly option.

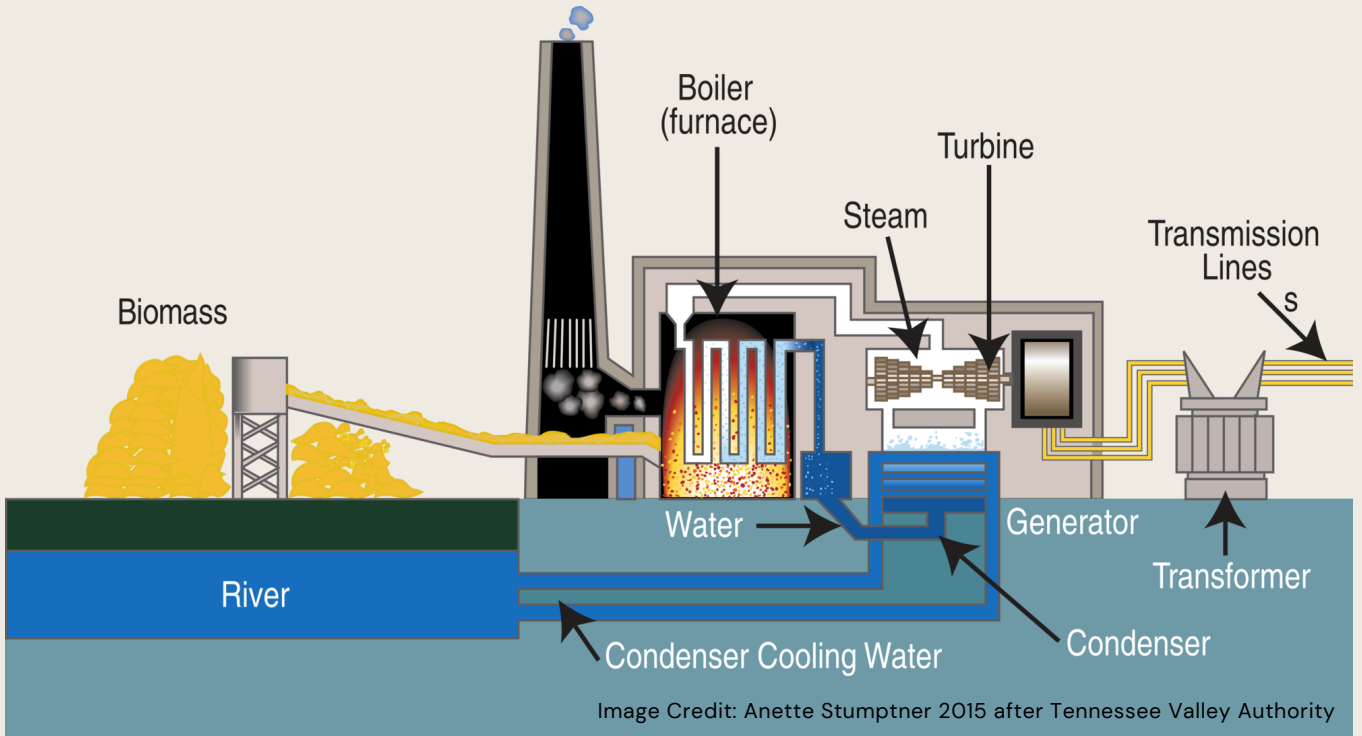

Figure 2.15 : Biomass Power Generation Plant / Direct combustion

BIOMASS POWER GENERATION BLOCK DIAGRAM

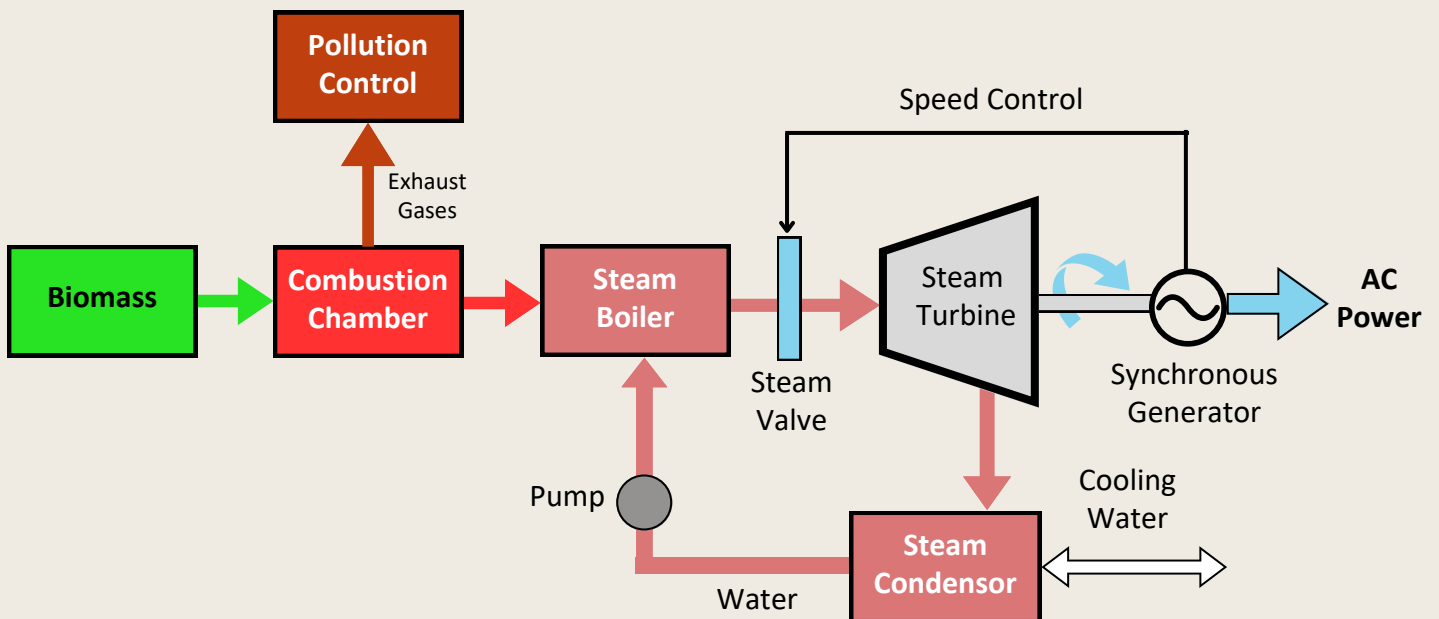
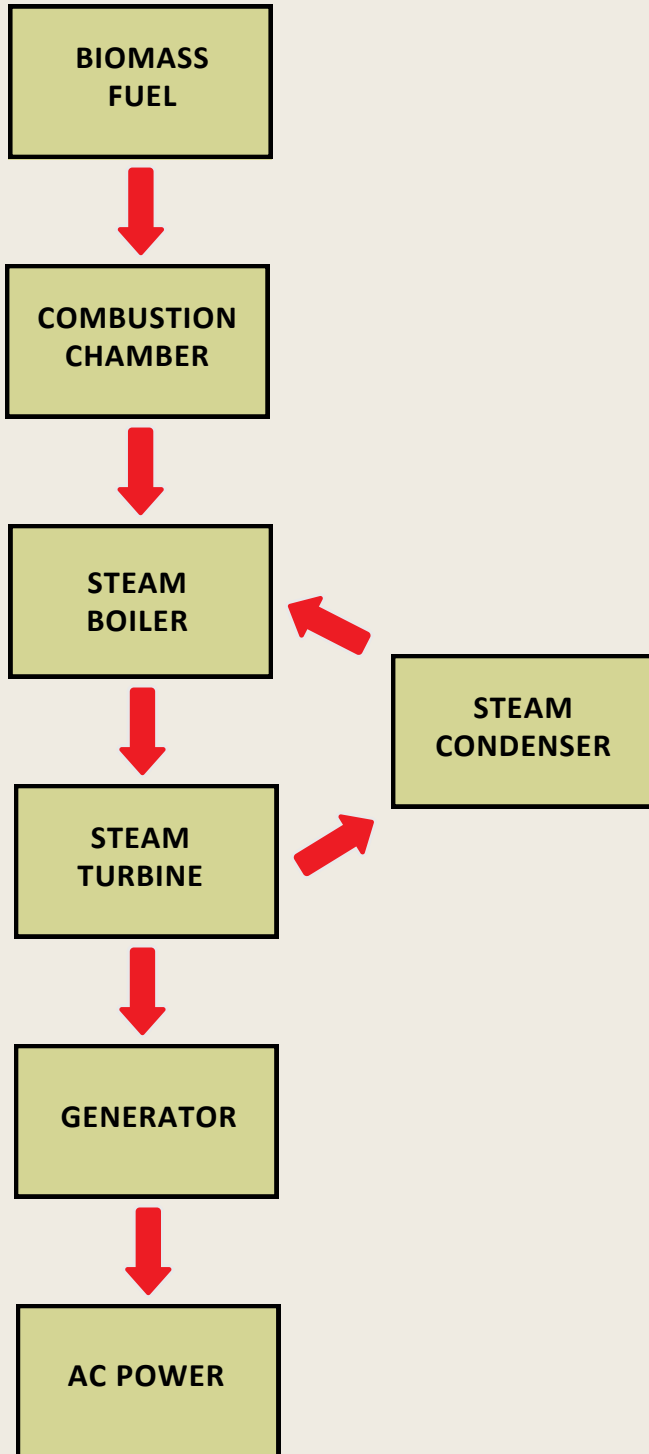

Figure 2.16 : Biomass power generation block diagram

OPERATIONAL OF BIOMASS POWER GENERATION



Biomass fuel include wood chips, pellets, sawdust, or bio-oil

Biomass feedstock into a **combustor** or **furnace** is burned to generate hot gas

Hot gas fed into a **steam boiler** to generate steam

Steam turbine converting the thermal energy of the steam into kinetic energy

The exhaust steam from the low pressure turbine is condensed to water in the **steam condenser**. It is then pumped back into the boiler as feed-water to be used again.

Rotary generator convert the turbine's mechanical energy into electrical energy (**AC power**).

Figure 2.17 : Operational of Biomass Power Generation

BIOMASS FOR ELECTRICITY GENERATION

Biomass can be converted into electric power through several methods:

- **Direct combustion** is the most common method of biomass material, such as agricultural waste or woody materials.
- **Gasification** produces a synthesis gas with usable energy content by heating the biomass with less oxygen than needed for complete combustion. Typically, woody biomass such as wood chips, pellets, and sawdust are combusted or gasified to generate electricity.
- **Pyrolysis** yields bio-oil by rapidly heating the biomass in the absence of oxygen. Most other types of biomass can be converted into bio-oil through pyrolysis, which can then be used in boilers and furnaces.
- **Anaerobic digestion** produces a renewable natural gas when organic matter is decomposed by bacteria in the absence of oxygen. Corn stover and wheat straw residues are baled for combustion or converted into a gas using an anaerobic digester. Very wet wastes, like animal and human wastes, are converted into a medium-energy content gas in an anaerobic digester.

ADVANTAGES & DISADVANTAGES OF BIOMASS ENERGY

ADVANTAGES

- ➡ Available almost everywhere
- ➡ Municipal, agricultural and industrial waste can be utilized for useful purposes
- ➡ It is an inexhaustible fuel source if there is a balance in production and consumption
- ➡ Sulphur, nitrogen oxides, and carbon emissions can be significantly reduced if biomass is used as source of energy

DISADVANTAGES

- ➡ Energy from biomass is more expensive than conventional fossil fuels
- ➡ It is a less concentrated form of energy
- ➡ Releases some emissions, especially if burned improperly

INTRODUCTION

2.6

BIOFUEL ENERGY

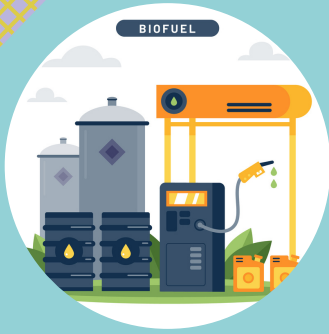

Biofuel is defined as liquid, solid, or gaseous fuel produced by conversion of biomass such as bioethanol from sugar cane or corn, charcoal or woodchips, and biogas from anaerobic decomposition of wastes. Biofuels can be used in many applications, including transportation, heating, and electricity generation.

CLASSIFICATION OF BIOFUEL

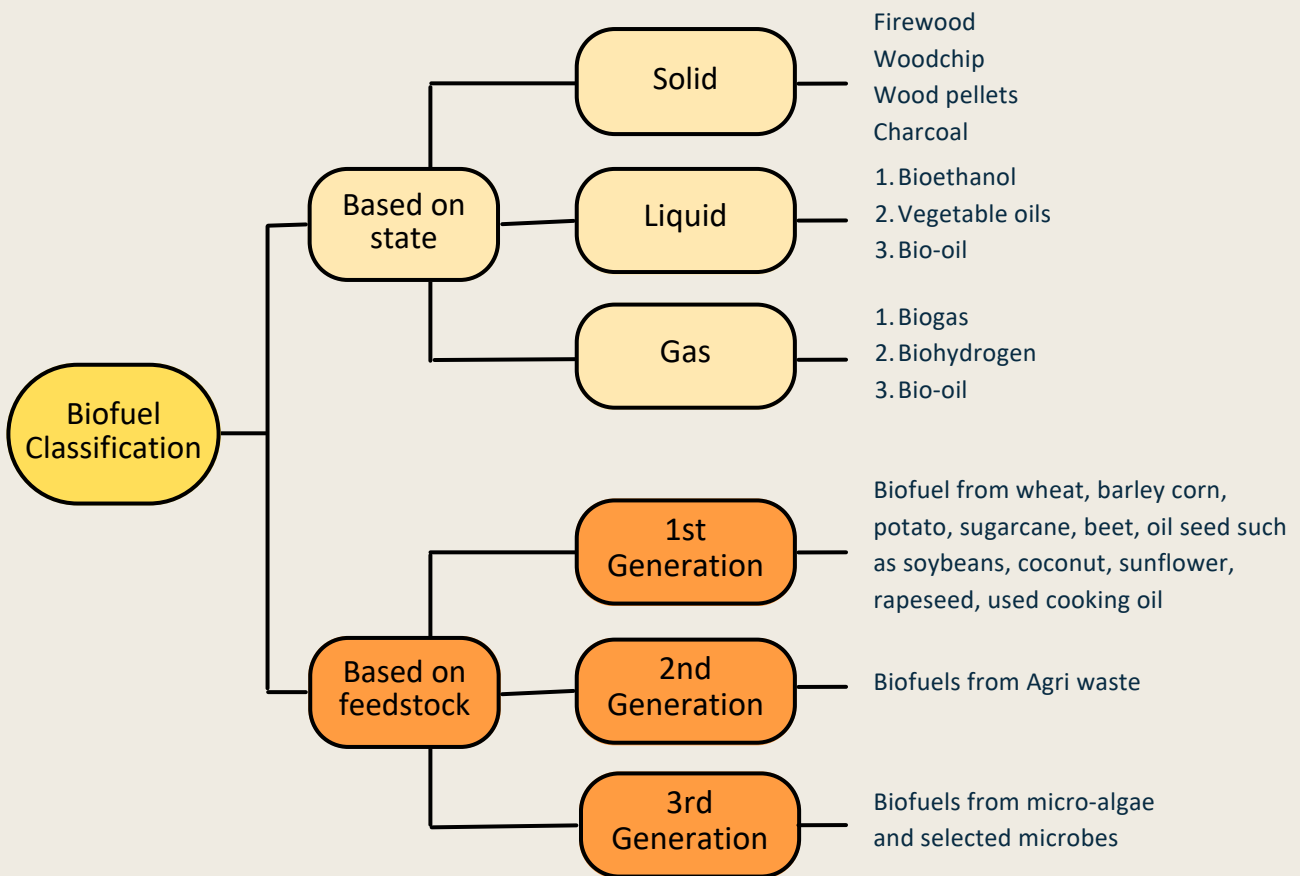

Figure 2.18 : Classification of biofuel

BIOMASS TO BIOFUEL CONVERSION

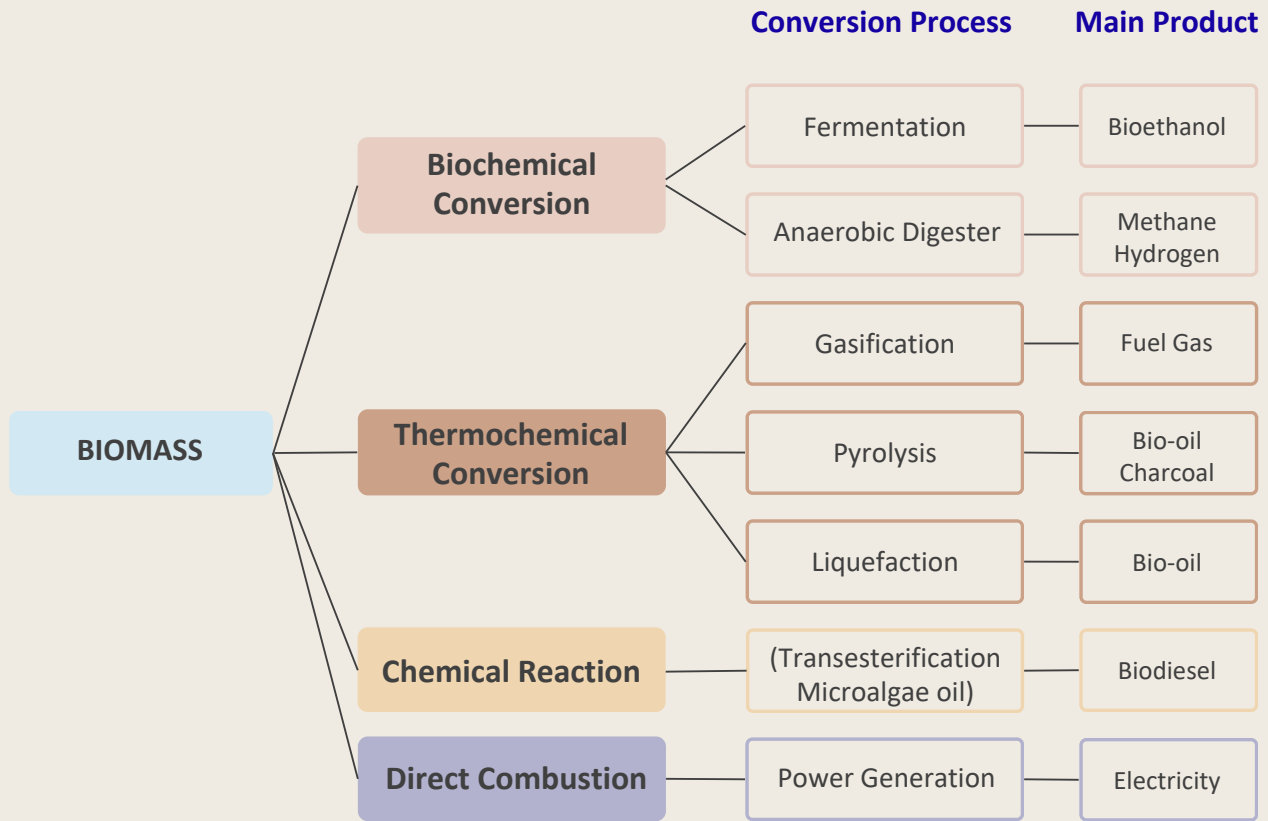

Figure 2.19 : Various biomass to biofuel processes



Why do we use biofuel energy?

Biofuel is a type of fuel that is produced from renewable biological resources, such as plant materials and animal waste. It is considered a sustainable alternative to fossil fuels because it emits less greenhouse gases when burned. The use of biofuels has grown in recent years as a way to reduce dependence on non-renewable energy sources and decrease carbon emissions.

TYPES OF BIOFUEL

1 Bioethanol

- Bioethanol fuel is created through the growth of plants such as sugar cane and corn, which are processed into ethanol via enzyme digestion, fermentation, distillation, and drying.
- Burning bioethanol for electricity generation produces lower emissions and is renewable, making it a cleaner alternative to fossil fuels.
- However, a larger stock of bioethanol is required to generate the same level of energy as other fuels, and there are challenges such as the amount of land needed to grow the crops and potential impact on food prices.

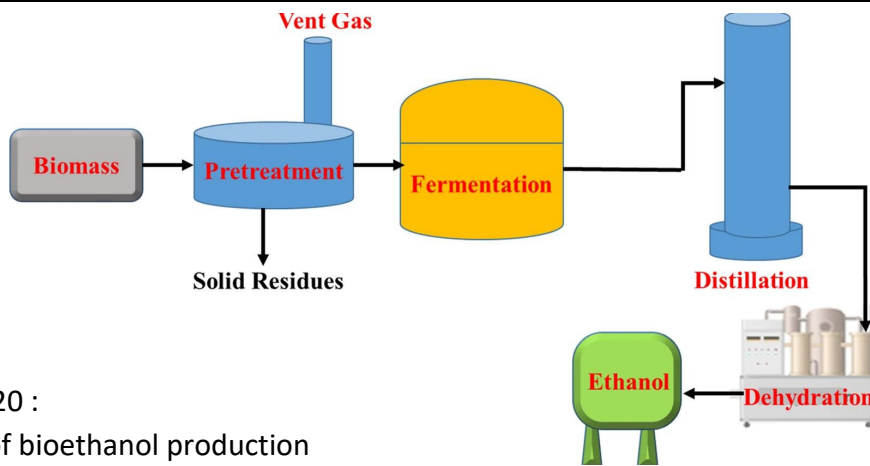

Figure 2.20 :
Process of bioethanol production

2 Biodiesel

- Biodiesel is produced from waste vegetable oils and animal fats through a process called transesterification, which separates glycerin from the fat or oil using methanol, leaving methyl esters. It is used to fuel diesel engines and can be blended with petroleum diesel in any percentage.
- Biodiesel is a clean-burning, renewable substitute for petroleum diesel that is biodegradable, burns cleaner with fewer greenhouse gas emissions, and is a sustainable, renewable source of energy.

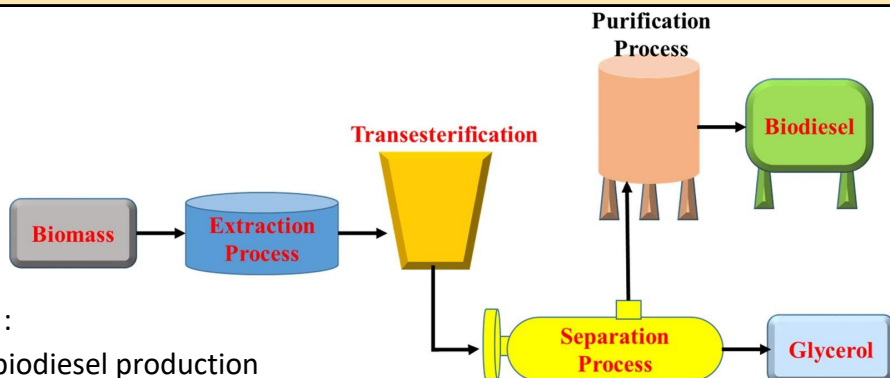

Figure 2.21 :
Process of biodiesel production

3 Methane gas and Biogas

- Biogas is produced through the anaerobic digestion of organic waste/matter in a biomass digester or plant, and is ideal when it has a higher methane percentage.
- It can be used as fuel for combustion engines to produce electricity, either on-site or sold onto the electric grid.
- Biogas is a renewable source of energy that reduces the amount of waste in landfills, has a positive impact on the climate, and reduces greenhouse gas emissions. However, biogas production can be expensive and requires a significant amount of land and resources.

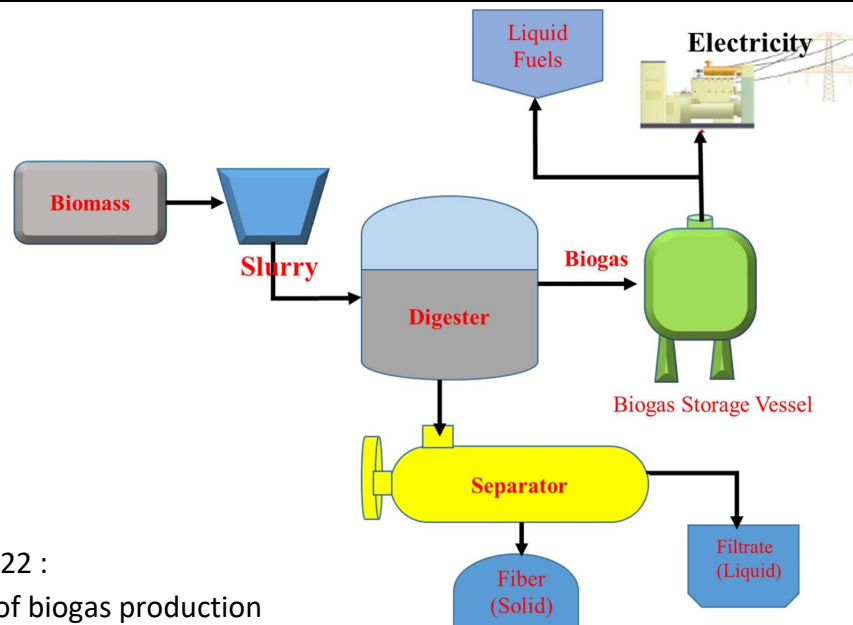

Figure 2.22 :
Process of biogas production

4 Biocoal

- Biocoal is a carbon-neutral fuel produced by the thermal conversion of biomass under oxygen-free conditions. It can replace fossil coal in industrial processes and can be used for electricity generation in the form of torrefied wood pellets.
- Biocoal has advantages such as being free of sulfur, nitrogen oxides, and mercury, and having a lower ash content than fossil coal, resulting in a cleaner burn and reducing greenhouse gas emissions. However, the production of biocoal requires significant amounts of energy and sourcing biomass can cause deforestation, negatively impacting biodiversity and carbon storage.

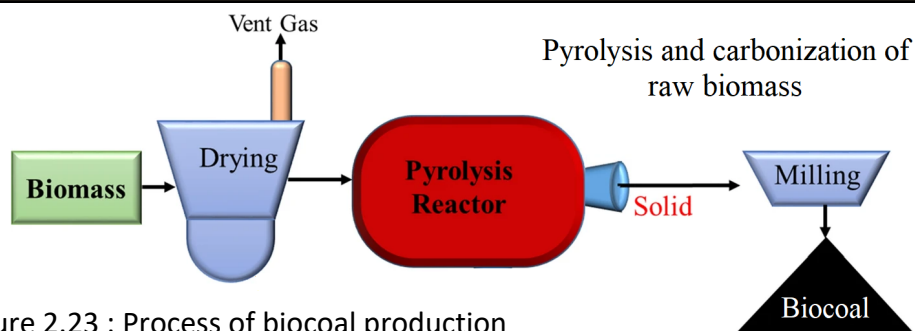

Figure 2.23 : Process of biocoal production

INTRODUCTION

2.7

GEOTHERMAL ENERGY



Geothermal energy is the heat produced deep in the Earth's core. Geothermal energy is a clean, renewable resource that can be harnessed for use as heat and electricity. Geothermal energy is a clean energy source that produces no greenhouse gas emissions and has a relatively small environmental footprint.

GEOTHERMAL ENERGY

How does Geothermal Energy Work?

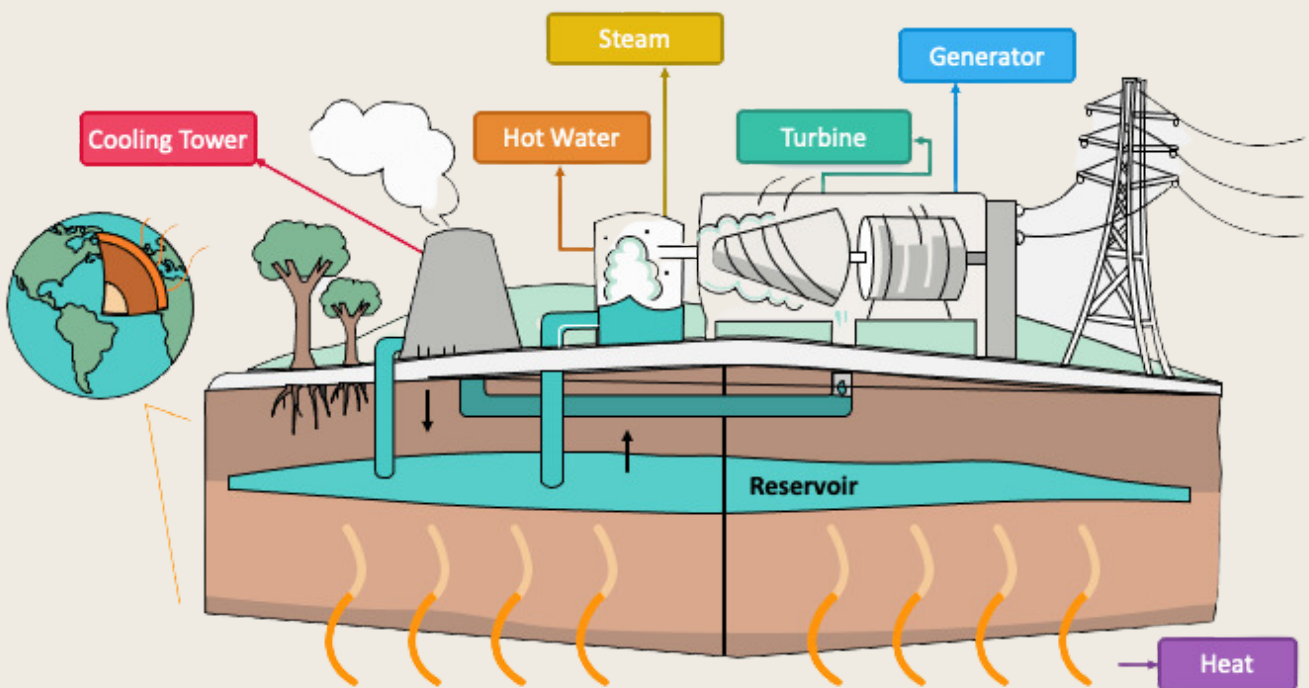

Figure 2.24 : Geothermal energy work

GEOHERMAL POWER PLANT

Geothermal power is electrical power generated from geothermal energy. Geothermal power plants draw fluids from underground reservoirs to the surface to produce steam. This steam then drives turbines that generate electricity.

GEOHERMAL POWER PLANT TECHNOLOGIES

1 Dry Steam Power Plant

- **Dry steam power plant** systems are the oldest type of geothermal power plants. This is only possible at the places having the highest temperatures. The temperature varies from 212°F to 608°F.
- Steam naturally produced from the ground is piped directly from underground wells to the power plant where it is directed into a turbine/generator unit.
- There are two different wells to reach a hot reservoir in the Earth's crust, the production well and the injection well. Dry steam power plant requires the least fluid flow.

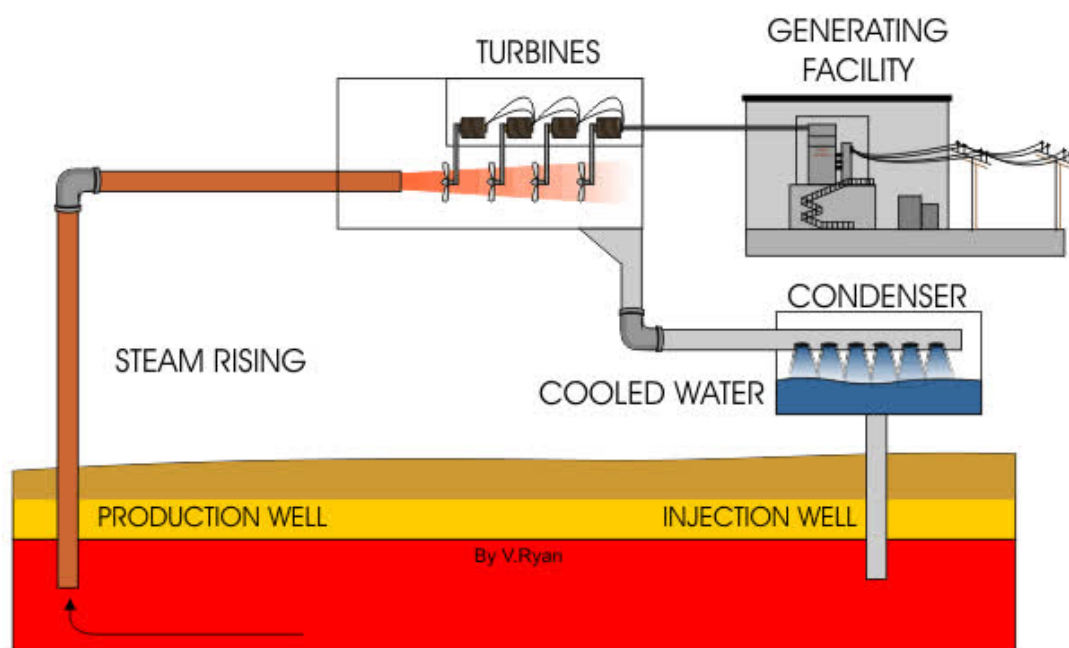

Figure 2.25 : Dry steam power plant diagram

2 Flash Steam Power Plant

- **Flash steam power plants** are the most common and use geothermal reservoirs of fluid with temperatures greater than 360°F (182°C).
- This very hot fluid flows up through wells in the ground under its own pressure. The change in pressure causes some of the fluid to rapidly transform, or “flash,” into vapor.
- The vapor then drives a turbine, which drives a generator. If any liquid remains in the low-pressure tank, it can be “flashed” again in a second tank to extract even more energy.
- Any leftover water and condensed steam are injected back into the reservoir, making this a sustainable resource.

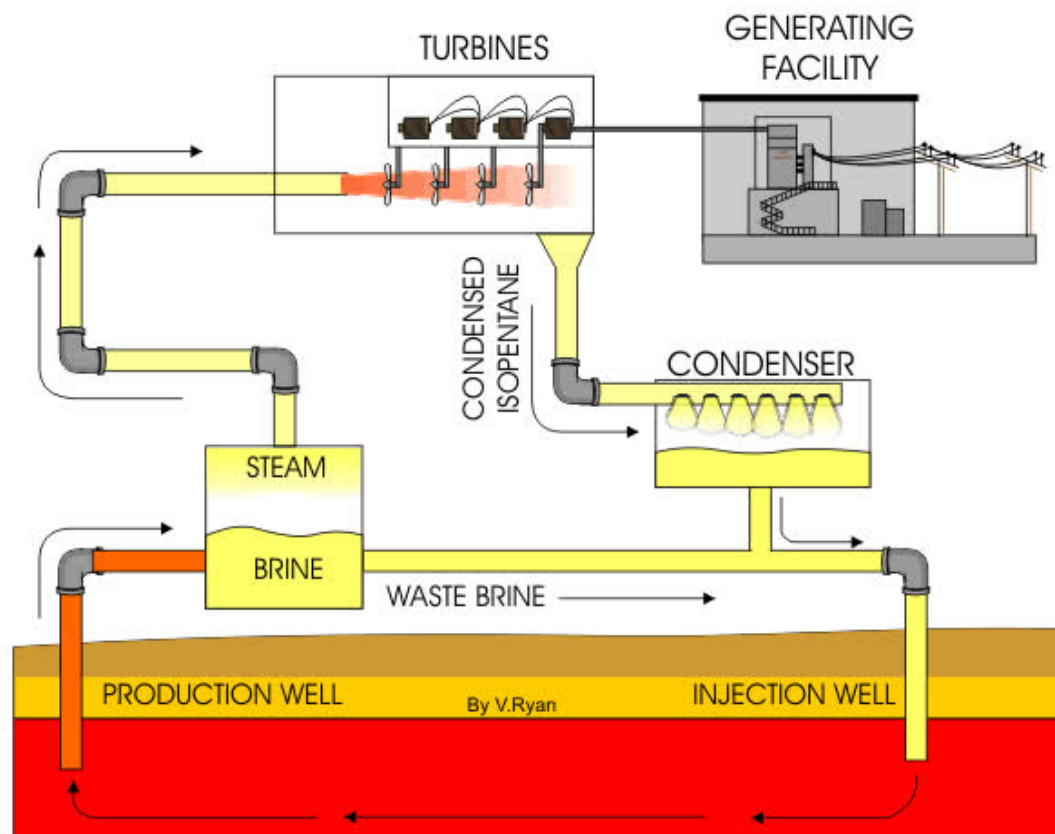

Figure 2.26 : Flash steam power plant diagram

3 Binary Cycle Power Plant

- **Binary cycle power plant** (binary means two) operate on water at lower temperatures of about 225-360°F (107-182°C).
- It use the heat from the geothermal hot water to boil a "working fluid" (usually an organic compound with a low boiling point), in separate adjacent pipes.
- The "working fluid" is vaporized in a heat exchanger and used to drives the turbines, spins the generators, and creates electricity. The water is then injected back into the ground to be reheated.
- The water and the working fluid are kept separated during the whole process, so there are little or no air emissions. Because this is a closed-loop system, virtually nothing is emitted to the atmosphere.

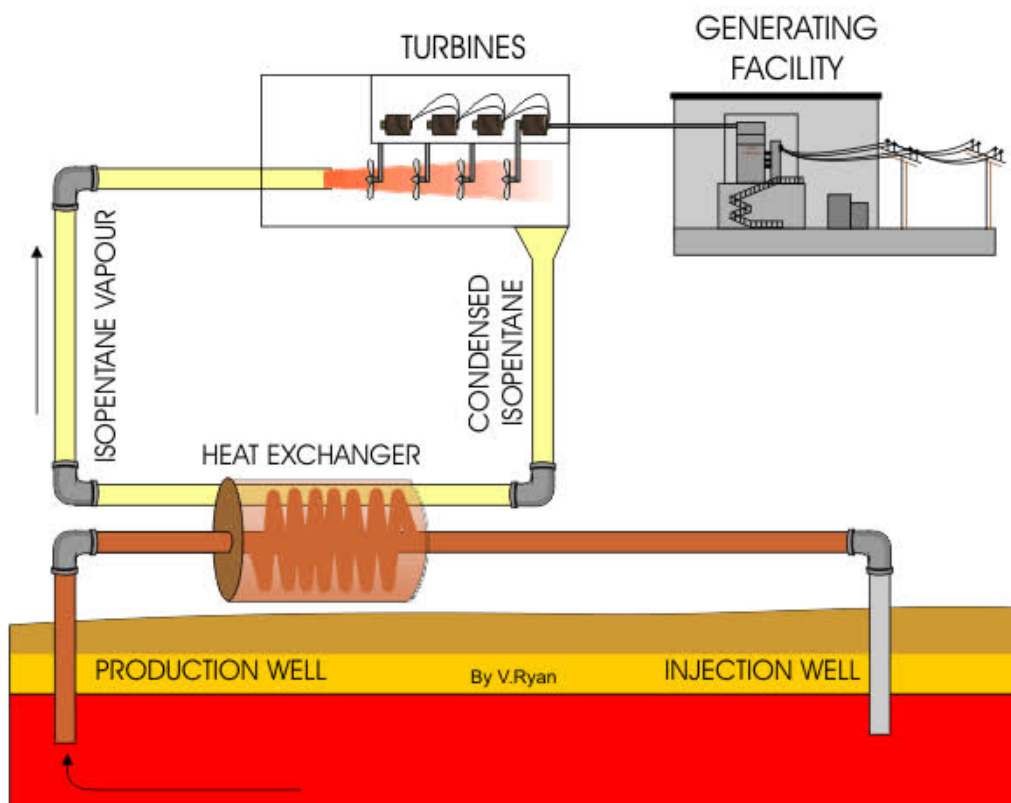

Figure 2.27 : Binary cycle power plant diagram

ADVANTAGES & DISADVANTAGES OF GEOTHERMAL ENERGY

ADVANTAGES

- ➔ Geothermal energy sourcing is good for the environment
- ➔ Geothermal energy is reliable source of renewable energy
- ➔ Geothermal systems have high efficiency
- ➔ There is too little to no geothermal system maintenance needed
- ➔ There is an unlimited supply of geothermal energy

DISADVANTAGES

- ➔ The extraction of geothermal energy sources causes greenhouse emissions
- ➔ There is possibility of depletion in geothermal sources
- ➔ There is a high-cost investment needed for geothermal systems
- ➔ It is hard to implement geothermal systems in big cities
- ➔ Geothermal reservoirs cannot easily found



The importance of Geothermal Energy

Geothermal energy is a renewable and clean source of energy that is generated from the Earth's internal heat. It has several advantages, including low operating costs, high efficiency, reliability, and versatility in its applications. This makes it an increasingly important alternative to traditional energy sources as the world moves towards a more sustainable future.

QUESTION

- 1 List **FIVE(3)** type of renewable energy sources.

- 2 Provide **THREE (3)** types of solar energy harnessing technologies.

- 3 Elaborate the differences between Horizontal-Axis Wind Turbines and Vertical-Axis Wind Turbine.

- 4 Explain the operational of hydro power station.

- 5 Elaborate **FOUR (4)** method convert biomass into electrical energy.

- 6 List **FOUR (4)** types of biofuel.

- 7 Explain dry steam powerplant.



3

C H A P T E R

ELECTRICAL GENERATION FROM NON-RENEWABLE SOURCES

3.1

SOURCES OF NON-RENEWABLE ENERGY



COAL

Coal is primarily used as fuel to generate electric power. Coal is formed from ancient plants' remains and extracted from underground mines or surface mining methods.



OIL

Oil energy works by combusting oil in oil-fired power plants. Oil is depletable because it comes from a finite liquid mixture of hydrocarbons beneath Earth's surface.

**NON-RENEWABLE ENERGY**

NATURAL GAS

Like other fossil fuels, natural gas can be burned for energy. Natural gas is a gaseous non-renewable resource that is found below the earth's crust but near crude oil deposits in the subsurface.

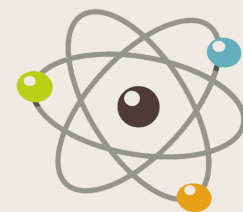

NUCLEAR

Nuclear fuels such as uranium and plutonium, are non-renewable resources as they are a finite material mined from the ground and can only be found in certain locations.

INTRODUCTION

3.2

FUEL-OIL



Fuel-oil is burned at power plants to create heat, which is then used to raise steam and turn turbines and create electricity. There are three kinds of oil products mostly used as power plant fuel: crude oil, diesel oil, and heavy fuel oil.

TYPES OF FUEL-OIL

1. Crude oil

Crude oil is extracted directly from the oil well in the purest condition. It forms the basis of all petroleum products, and it has more than 500 components. According to its sulfur content, crude oil can be “sweet” (low sulfur content) or “sour” (high sulfur content).

2. Diesel oil

Diesel oil is a blend of different middle distillates derived from the crude oil refining process. It is usually composed of light and heavy gas oil, light and heavy cycle oil, as well as vacuum gas oil.

3. Heavy fuel oil

Heavy fuel oil (HFO), also known as “residual fuel oil”, is based on the high viscosity, tar-like mass, which remains after the distillation and subsequent cracking of crude oil in the refining process. As a residual product, HFO is relatively inexpensive, it typically costs 30% less than distillate fuels and less than crude oil.

OIL-FIRED POWER PLANT

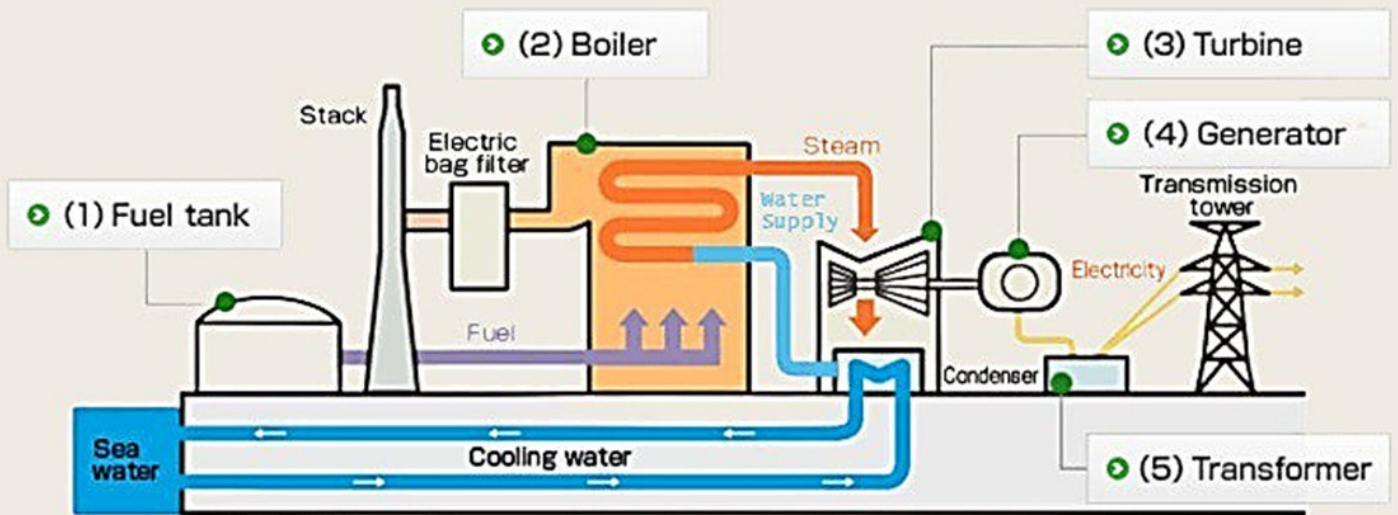

Figure 3.1 : Diagram of oil-fired power plant

OPERATIONAL BLOCK DIAGRAM OF OIL-FIRED POWER PLANT

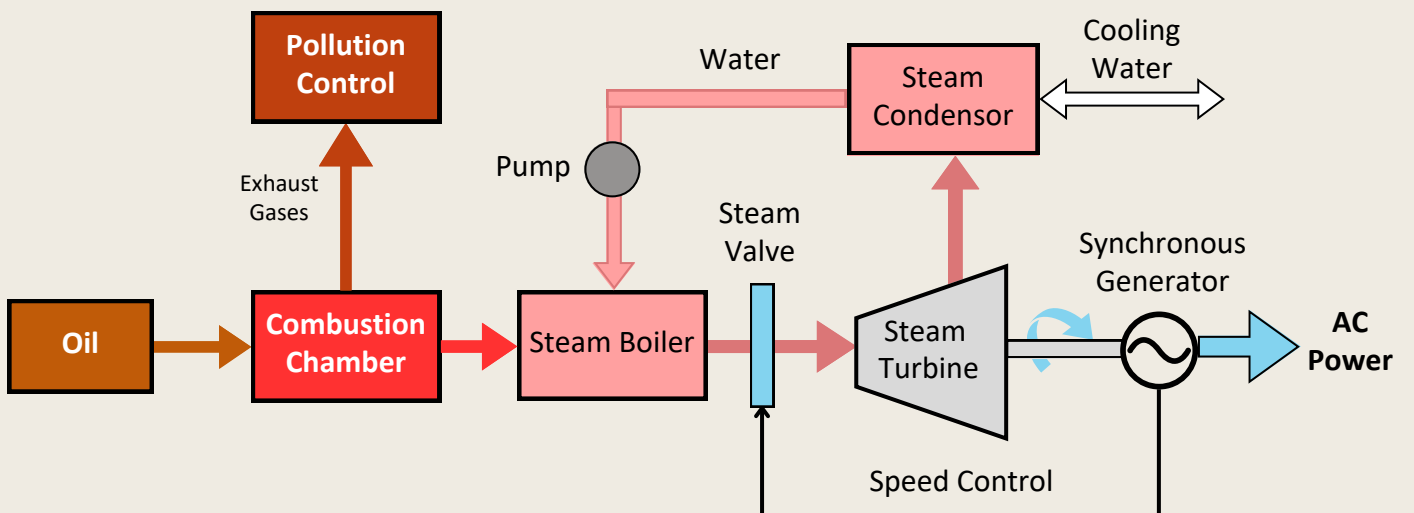

Figure 3.2 : Block diagram of Oil-fired Power Plant

OPERATIONAL OF OIL-FIRED POWER PLANT

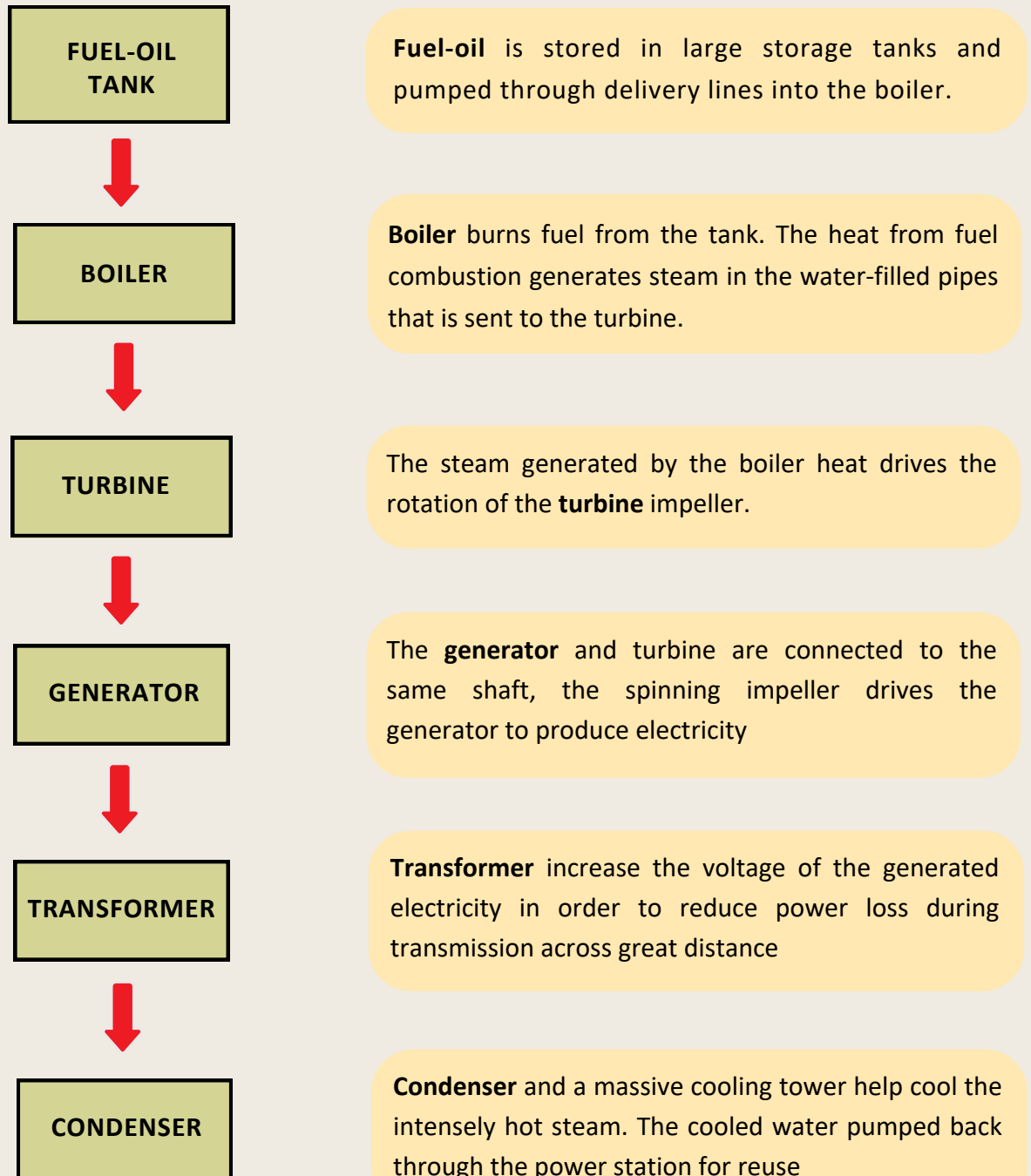

Figure 3.3 : Operational of Oil-fired Power Plant

ADVANTAGES & DISADVANTAGES OF OIL-FIRED POWER PLANT**ADVANTAGES**

- ➔ Oil-fired power plant can generate a massive amount of electricity.
- ➔ It easily accessible and reasonably priced
- ➔ Oil may be conveniently transported via pipes. They have become safer over time
- ➔ Despite the fact that it is a limited resource, it is abundant.

DISADVANTAGES

- ➔ When these oil-fuel are burned, it emit nitrous and sulfur oxides, methane, mercury compounds, and significant amounts of carbon dioxide
- ➔ Require large quantities of water for the production of steam and for cooling
- ➔ Results in residues called sludge that are not completely burned and therefore require disposal in landfills
- ➔ Because nonrenewable energy resources are finite in supply, it will eventually run out

***Fuel-oil power plant***

Power plants that burn petroleum liquids (such as distillate or residual fuel oils) are generally used for short periods during peak electricity demand because of the high price of petroleum relative to other fuels. Most oil-fired generators are either turbines or internal combustion engines used to supply power only at peak electric power demand or when natural gas prices rise due to local natural gas demand.

INTRODUCTION

3.3

COAL

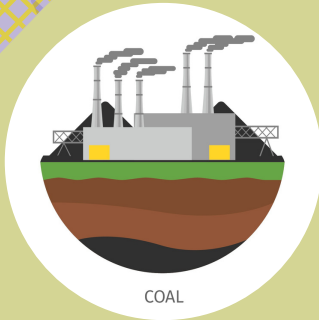

Coal comes in different quantity levels of carbon which dictates the quality of the coal. Higher quality coal produces less smoke, burns longer, and provides more energy than lower quality coal. Coal is a solid form fossil fuel that can be classified into 3 types which are lignite, bituminous and anthracite.

TYPES OF COAL



Lignite coal is found close to the earth surface and the lowest quality of coal. It is soft and ranges in color from black to shades of brown. Lignite is mainly used for electricity generation and accounts for 17% of the world's coal reserves.



Bituminous coal is harder and blacker than lignite. It makes up 52% of the world's coal reserves and account for a majority of the coal industry. It is less polluting from lignite.



Anthracite is the highest quality of coal. It is dark and shiny and found deeper in the earth. Coal mines that produce anthracite account for roughly 1% of the world's total coal reserves.

COAL-FIRED POWER PLANT

Coal-fired plants produce electricity by burning coal in a boiler to produce steam. The steam produced, under tremendous pressure, flows into a turbine, which spins a generator to create electricity. The steam is then cooled, condensed back into water and returned to the boiler to start the process over.

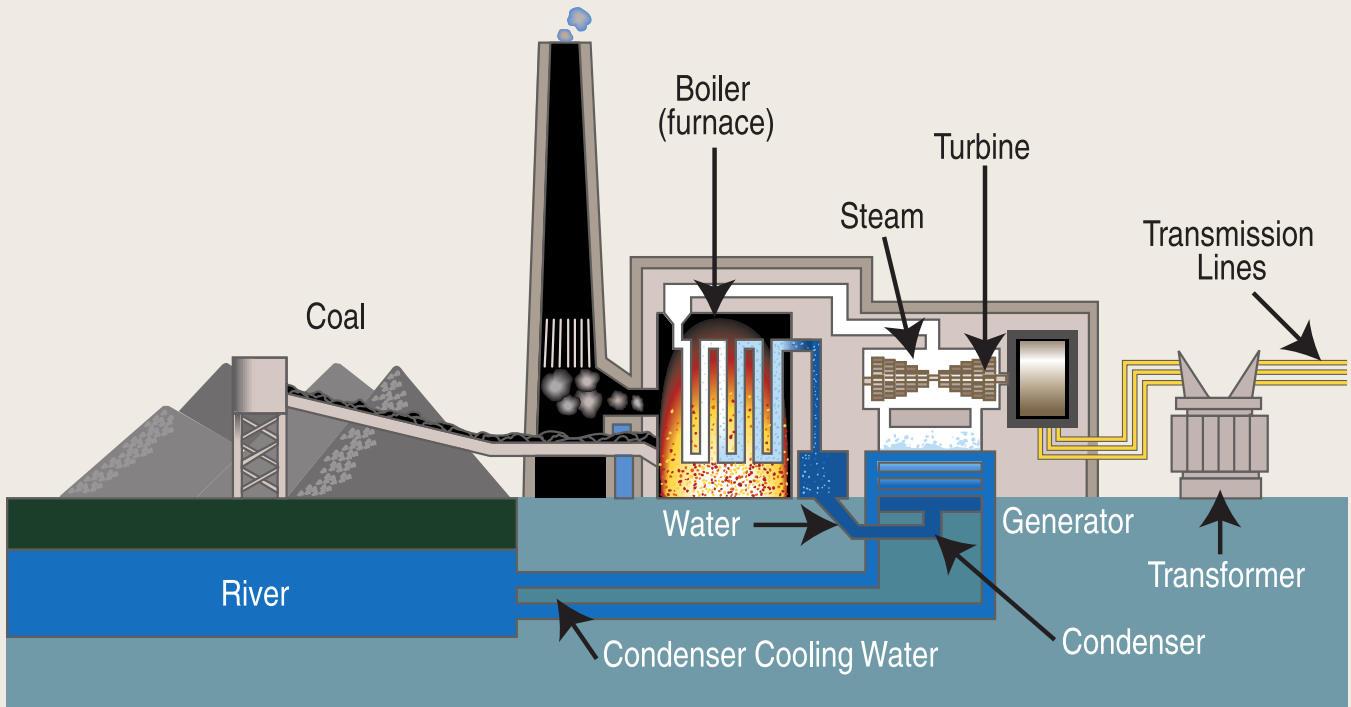

Figure 3.4 : Coal-fired Power Plant Diagram

COAL-FIRED POWER PLANT BLOCK DIAGRAM

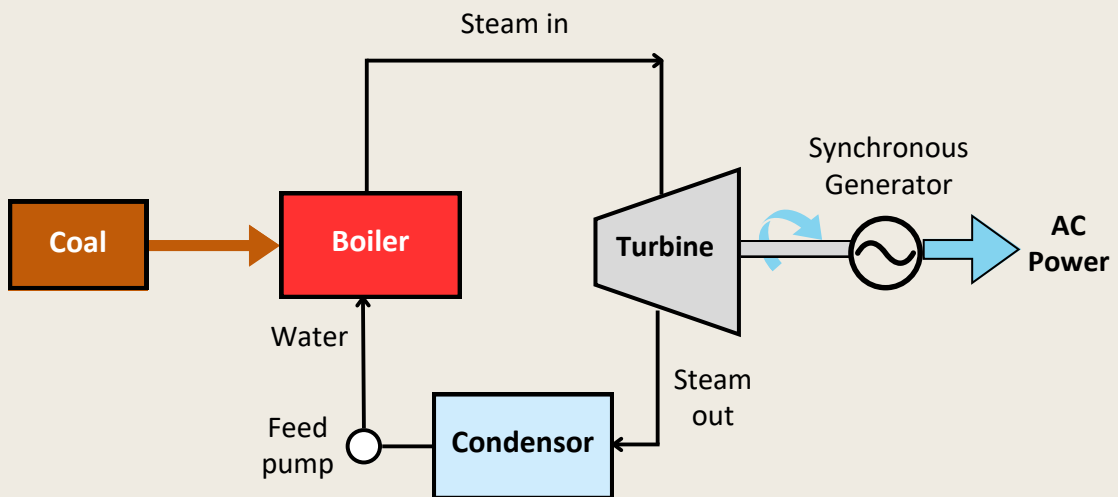

Figure 3.5 : Block diagram of Coal-fired Power Plant

OPERATIONAL OF COAL-FIRED POWER PLANT

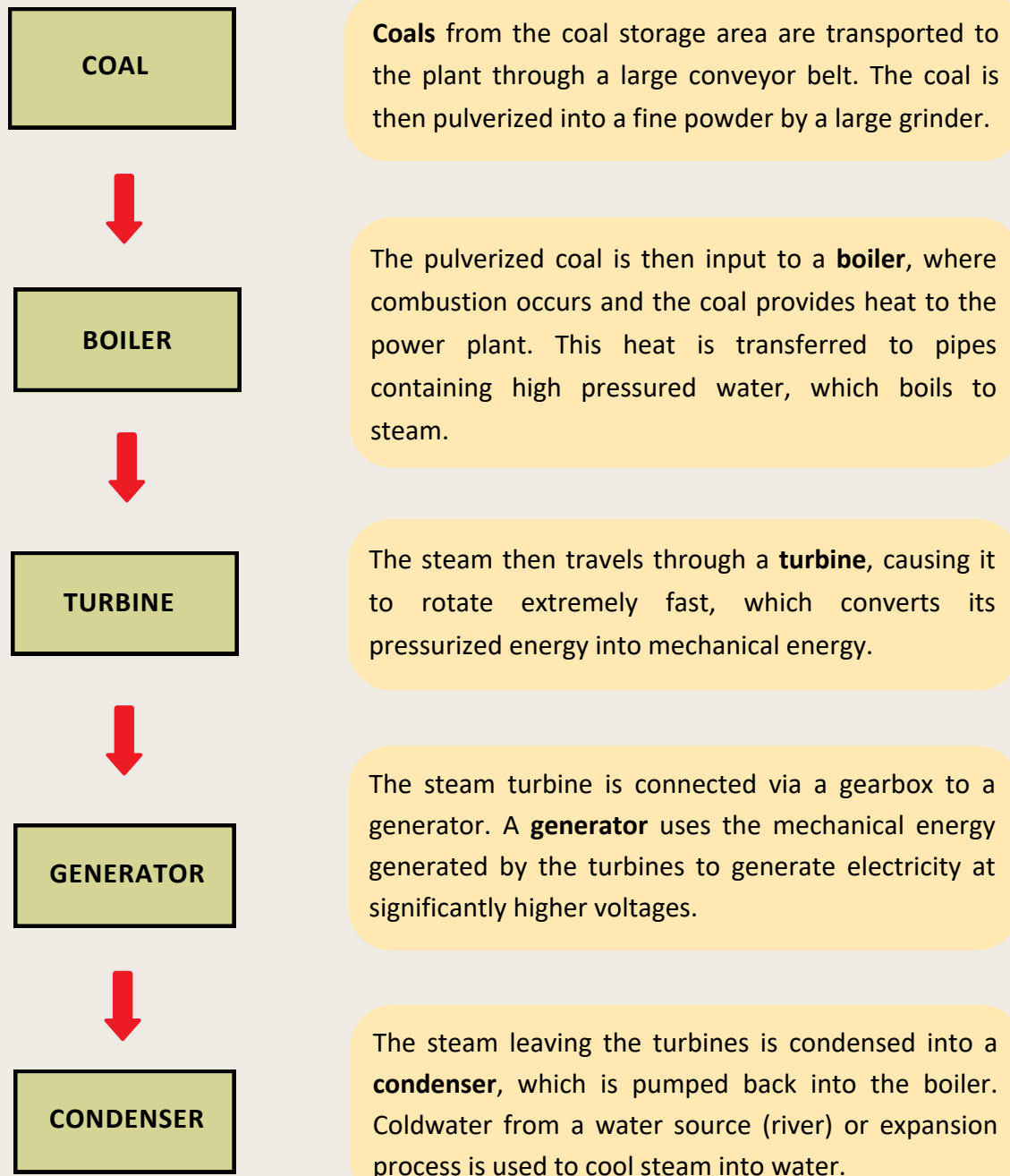

Figure 3.6 : Operational of Coal-fired Power Plant

ADVANTAGES & DISADVANTAGES OF COAL-FIRED POWER PLANT**ADVANTAGES**

- ➔ Burning coal is one of the cheapest ways to generate power
- ➔ Coal power stations can be built anywhere where there are good transport links and a plentiful supply of cooling water
- ➔ The world has many coal reserves
- ➔ Coal is safe to store and transport

DISADVANTAGES

- ➔ Burning coal produces carbon dioxide, which contributes to the greenhouse effect. It also produces sulphur dioxide (forms acid rains).
- ➔ Coal is not renewable. There are limited supplies which will run out one day
- ➔ Coal-fired power plants need huge amount of fuel
- ➔ Mining coal has negative environmental impact

*Coal-fired power plant*

- Coal fired power plant are the most common type of power plant and the largest global megawatt (MW) contributor of all power plant types.
- This type of power plant has found widespread application due to its tried and tested design, as well as the cheap availability of coal.
- Unfortunately, coal fired power plants (particularly older plants) are not environmentally friendly compared to other types of power generation plants. Coal fired power plants are non-renewable (not 'green') types of plant.

INTRODUCTION

3.4

NATURAL GAS



Natural gas is a mixture of gases which are rich in hydrocarbons. All these gases (methane, nitrogen, carbon dioxide etc) are naturally found in atmosphere. Natural gas reserves are deep inside the earth near other solid & liquid hydrocarbons beds like coal and crude oil.

MAIN COMPONENT OF NATURAL GAS

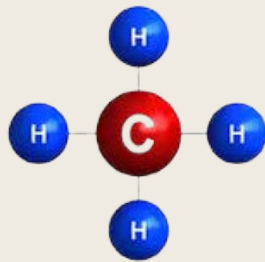

METHANE

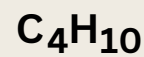
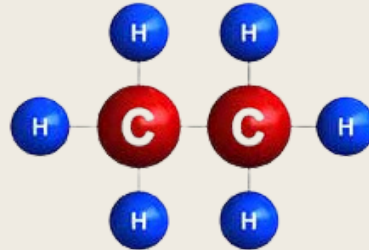

ETHANE

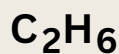
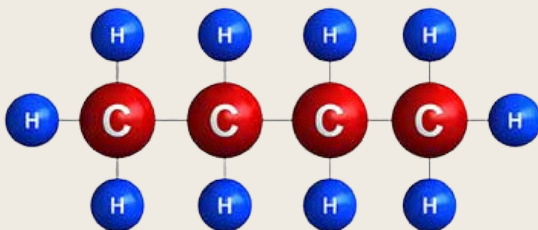

BUTANE

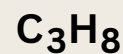
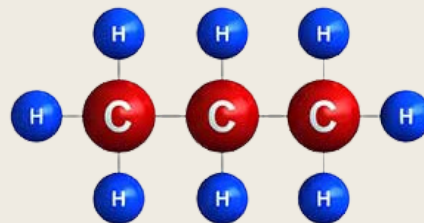

PROPANE

Figure 3.7 : Main component of natural gas

GAS TURBINE POWER PLANT

A gas turbine power plant generates electricity through the combustion of natural gas or other fuels. The process involves compressing air and mixing it with fuel, which is then ignited to produce a high-pressure, high-velocity stream of hot gases. These gases drive a turbine, which converts the energy into electricity.

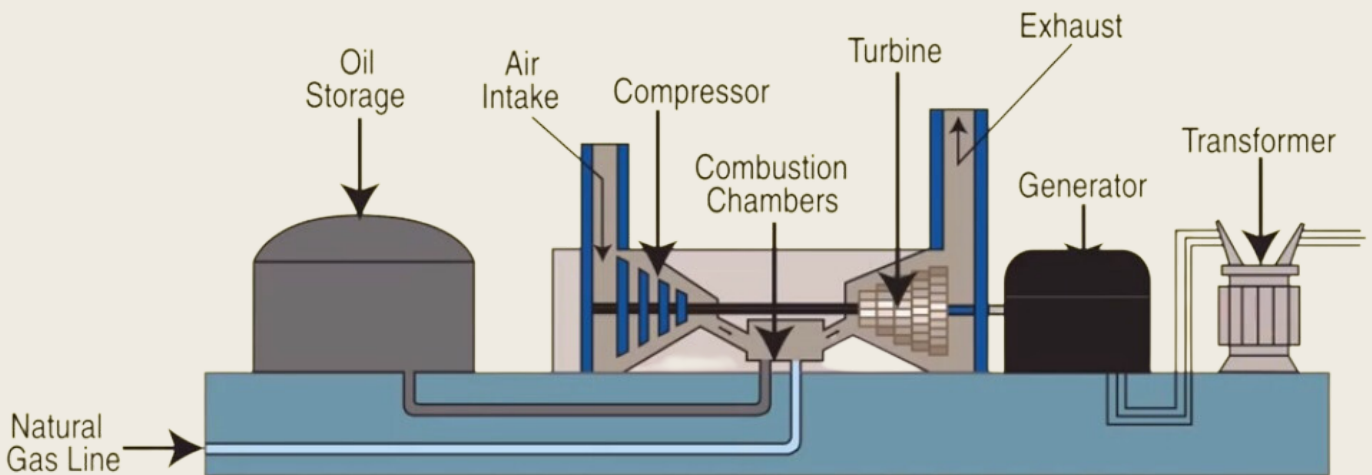

Figure 3.8 : Diagram of Gas Turbine Power Plant

BLOCK DIAGRAM OF GAS TURBINE POWER PLANT

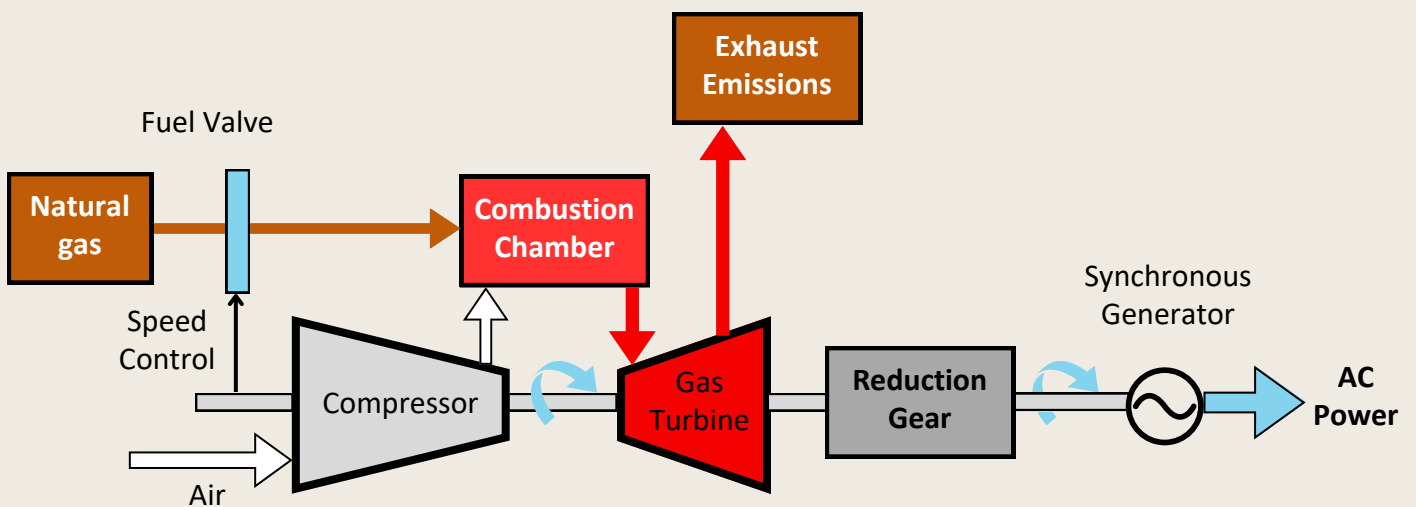

Figure 3.9 : Block diagram of Gas Turbine Power Plant

OPERATIONAL OF GAS TURBINE POWER PLANT

AIR
COMPRESSOR



COMBUSTION
CHAMBER



TURBINE

The **air compressor** and turbine or mounted at either end on a horizontal axle shaft with the combustion chamber between them. The main work of the air compressor is to compress the air and increase its pressure.

In the **combustion chamber** the compressed air combines with fuel and the resultant mixture is burnt. In some cases the liquid fuels are also used but mostly the gases are used as fuel. A spark plug is used for the ignition to burn the mixture of gas. The air compressor and combustion chamber is also called gas generator because it produce hot gases.

The burning gases expand rapidly and rush into the **turbine** where they cause the turbine wheels to rotate. The shaft of the turbine is coupled to generator to drive it. To increase the efficiency of the gas turbine multistage gas turbine can also be used. Then the exhaust must be released in to the atmosphere.

Figure 3.10 : Operational of Gas Turbine Power Plant

ADVANTAGES & DISADVANTAGES OF GAS TURBINE POWER PLANT**ADVANTAGES**

- ➔ It is simple in design and much smaller size to steam power plant
- ➔ It's easy to start up a gas turbine power plant in cold conditions.
- ➔ Initial and operating cost is low as compared to other plant
- ➔ Since no condenser is used, it requires comparatively less water
- ➔ Short startup time

DISADVANTAGES

- ➔ Life of gas turbine plant is comparatively lower than other plant
- ➔ Net output is much smaller than other plant. This is due to the fact that the turbine uses a greater percentage of its energy to drive the compressor
- ➔ Starting of this plant needs some external power.
- ➔ Generally, gas turbine power plants have a low overall efficiency, about 20%, due to the large amount of heat that is contained in the exhaust gases getting wasted.

***Where Does Natural Gas Come From?***

Natural gas was formed millions of years ago when heat and pressure transformed decaying plant and animal matter buried in sedimentary rock layers. Normally, natural gas is trapped under layers of rock that prevent it from flowing easily to the surface.

INTRODUCTION

3.5

NUCLEAR

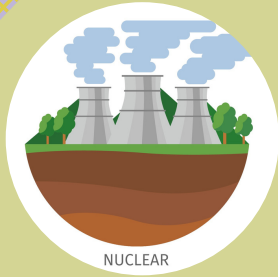

Nuclear power generation using the heat generated by nuclear reactions to produce steam, which then drives a turbine connected to a generator to produce electricity. The process involves splitting atoms of uranium in a controlled chain reaction. Nuclear energy is a form of energy released from the nucleus, the core of atoms, made up of protons and neutrons.

CHAIN REACTION OF NUCLEAR ENERGY

1

Fission

- Fission – when nuclei of atoms split into several parts
- Nuclear fission releases heat energy by splitting atoms
- When a heavy unstable nucleus of an atom breaks up into two or more lighter nuclei, a large amount of energy is released. This phenomenon is called the nuclear fission

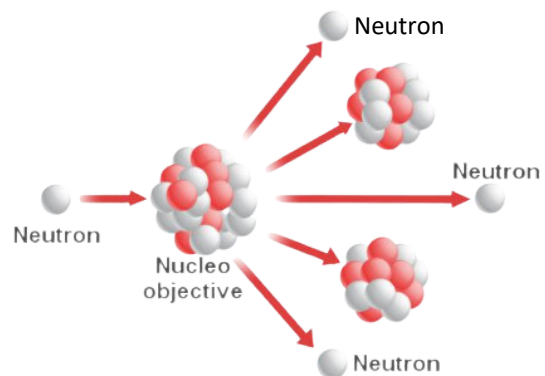

Figure 3.11 : Diagram of Fission

2

Fusion

- Fusion – when nuclei fuse together
- Nuclear fusion is a process in which two or more lighter nuclei combine or fuse together to form a heavier and stable nuclide. In nuclear fusion, the sum of mass of lighter nuclei is always greater than the mass of heavy nucleus

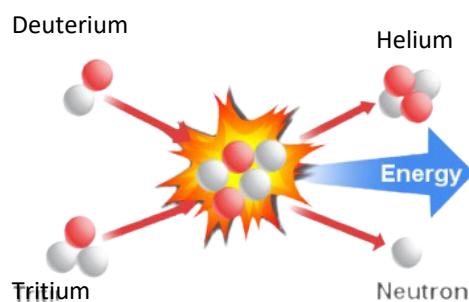

Figure 3.12 : Diagram of Fusion

NUCLEAR POWER PLANT

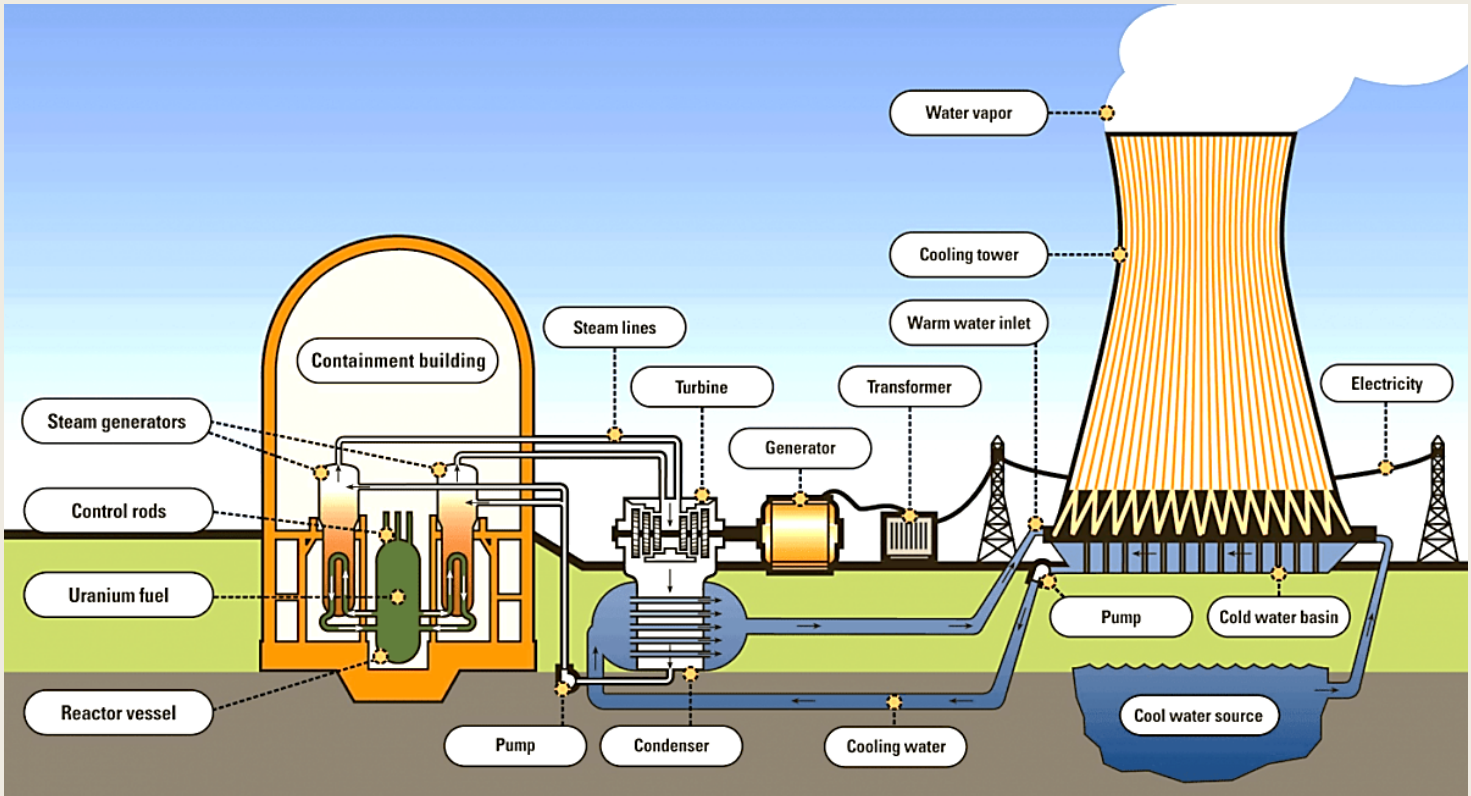

Figure 3.13 : Diagram of Nuclear Power Plant

BLOCK DIAGRAM OF NUCLEAR POWER PLANT

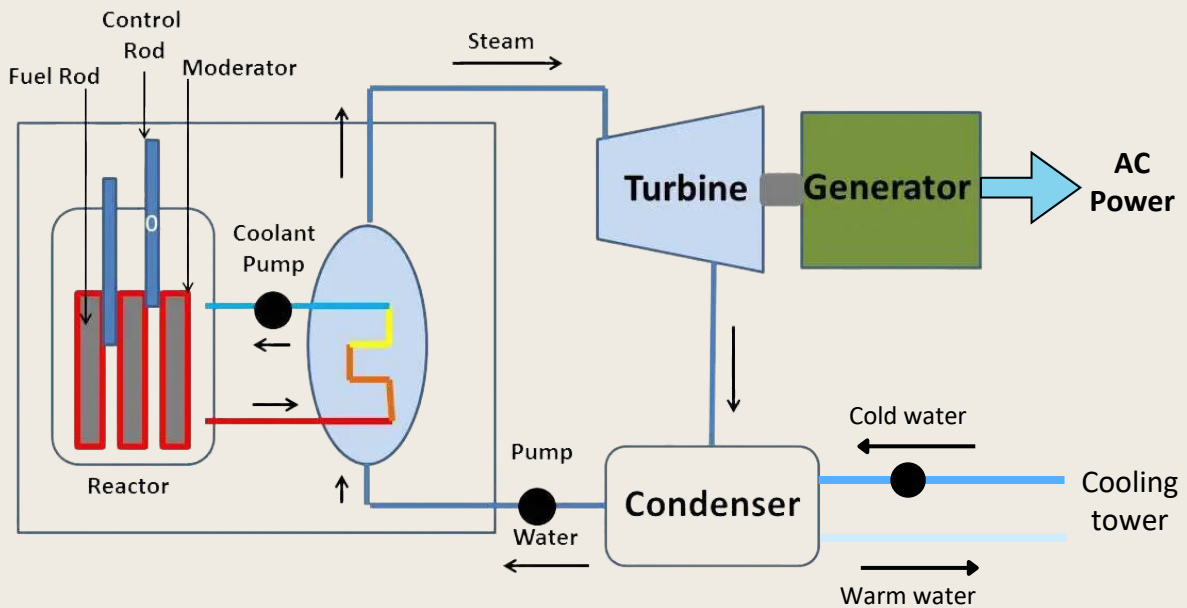

Figure 3.14 : Block diagram of Nuclear Power Plant

OPERATIONAL OF NUCLEAR POWER PLANT

NUCLEAR REACTOR



HEAT EXCHANGER



STEAM TURBINE



ALTERNATOR



CONDENSER

Nuclear Reactor is the main component of the nuclear power plant, where the chain reaction nuclear fission takes place. The nucleus is composed of the fuel elements.

In the **heat exchanger**, the primary coolant transfers heat to the secondary coolant (water). Thus water from the secondary loop is converted into steam. The primary system and secondary system are closed loop, and they are never allowed to mix up with each other

Generated steam is passed through a **steam turbine**, which runs due to pressure of the steam. As the steam is passed through the turbine blades, the pressure of steam gradually decreases and it expands in volume

Alternator is a system that produces electricity by converting the turbine's mechanical rotation energy into medium-power, high-intensity electric energy

The steam coming out of the turbine, after it has done its work, is then converted back into water in a **condenser**. The steam is cooled by passing it through a third cold water loop. Sometimes cooling tower is used for condensing the steam in case of large power plants.

Figure 3.15 : Operational of Nuclear Power Plant

ADVANTAGES & DISADVANTAGES OF NUCLEAR POWER PLANT

ADVANTAGES

- ➔ Produce no polluting gases, such as carbon dioxide
- ➔ Require far less fuel as uranium provides far more energy per kg compared to coal and other fossil fuel
- ➔ Low operating costs
- ➔ Are highly reliable for the production of electricity

DISADVANTAGES

- ➔ Produces radioactive waste which is very dangerous and expensive to deal with.
- ➔ Can have catastrophic consequences on the environment and to the people in the surrounding area in the event of a nuclear meltdown, such as Chernobly
- ➔ Have expensive initial cost and shut down costs
- ➔ Highly technical person is required for erection and commissioning



How is nuclear energy obtained?

Nuclear energy is obtained by the disintegration of uranium atoms in nuclear power plants. Uranium is the main source of fuel for these installations because its instability generates reactions that nuclear power plants provoke to obtain energy. In some cases plutonium is also used.

NUCLEAR POWER PLANT ACCIDENTS

- Nuclear power plants have safety and security procedures in place and are closely monitored by the **Nuclear Regulatory Commission (NRC)**.
- An accident at a nuclear power plant could release dangerous levels of radiation over an area (sometimes called a plume).

What are the main dangers of nuclear power plant accidents?

- Radioactive materials in the plume from the nuclear power plant can settle and contaminate people who are outdoors, buildings, food, water, and livestock
- Radioactive materials can also get inside the body if people breathe it in, or eat or drink something that is contaminated.
- People living close to the nuclear power plant who are exposed to radiation could experience long-term health effects such as cancer



Nuclear Energy

Despite concerns about safety and waste disposal, nuclear power remains a significant source of energy in many countries. Some argue that it is a necessary part of the world's energy mix due to its low carbon emissions, while others advocate for investing in renewable energy sources instead.

QUESTION

- ① List **THREE (3)** type of fossil fuels.

- ② Explain the operational process of coal-fired power plant.

- ③ Explain the definition of coal.

- ④ List the main components of natural gas.

- ⑤ Sketch gas turbine power plant block diagram.

- ⑥ Explain chain reaction of nuclear energy.

- ⑦ Explain the operational process of nuclear power plant.

A N S W E R

SCAN THE QR CODE
FOR ANSWER



SCAN ME

REFERENCES

Ahmed F. Zobaa & Ramesh C. Bansal (2011). *Handbook of Renewable Energy Technology*. Copyright © 2011 by World Scientific Publishing Co. Pte. Ltd

Benti, N. E., Gurmesa, G. S., Argaw, T., Aneseyee, A. B., Gunta, S., Kassahun, G. B., Aga, G. S., & Asfaw, A. A. (2021). *The current status, challenges and prospects of using biomass energy in Ethiopia*. *Biotechnology for Biofuels*, 14(1). <https://doi.org/10.1186/s13068-021-02060-3>

Bouquet, A. (2013, April 25). *Bioethanol electricity*. TheGreenAge - The Home of Energy Saving. <https://www.thegreenage.co.uk/tech/bioethanol-electricity/>

Cheng, B.-H., Huang, B.-C., Zhang, R., Chen, Y.-L., Jiang, S.-F., Lu, Y., Zhang, X.-S., Jiang, H., & Yu, H.-Q. (2020). *Bio-coal: A renewable and massively producible fuel from lignocellulosic biomass*. *Science Advances*, 6(1). <https://doi.org/10.1126/sciadv.aay0748>

Danso-Boateng, E., & Achaw, O.-W. (2022). *Bioenergy and biofuel production from biomass using thermochemical conversions technologies—a review*. *AIMS Energy*, 10(4), 585–647. doi:10.3934/energy.2022030

Fahad, E. (2021, January 5). *Gas Turbine Power Plant and types of gas turbine*. *Electronic Clinic*. <https://www.electronicclinic.com/gas-turbine-power-plant-and-types-of-gas-turbine/>

Farnoosh, A. (2022). *Power generation from coal, oil, gas, and biofuels*. In *The Palgrave Handbook of International Energy Economics* (pp. 111–130). Cham: Springer International Publishing.

Kirtley, J. L. (2010). *Electric Power Principles: Sources, Conversion, Distribution and Use*. Hoboken, United States: John Wiley and Sons Ltd

What is Concentrated Solar Power and how does CSP work? (20210304T071300). Brunel. <https://www.brunel.net/en/blog/renewable-energy/concentrated-solar-power>

WikimediaCommons[Online]. Available: https://upload.wikimedia.org/wikipedia/commons/thumb/4/4a/Coal_fired_power_plant_diagram.svg/1280px-Coal_fired_power_plant_diagram.svg.png

ELECTRICAL POWER GENERATION

e ISBN 978-967-2897-95-8



POLITEKNIK PORT DICKSON

(online)