

# INTRODUCTION TO ELECTRIC CIRCUIT

## Ohm's Law



AUTHORS:  
Ts. FAUZIAH BINTI CHE MAT  
KARTHEGA A/P SHANMUGAM

# INTRODUCTION TO ELECTRIC CIRCUIT

**Ohm's Law**



Cataloguing-in-Publication Data

Perpustakaan Negara Malaysia

A catalogue record for this book is available  
from the National Library of Malaysia

eISBN 978-629-7643-39-7

**All rights reserved.**

No part of this publication may be reproduced, stored in a retrieval system, or transmitted in any form or by any means, electronic, mechanical, photocopying, recording, or otherwise, without the prior permission of Jabatan Pengajian Politeknik dan Kolej Komuniti, Kementerian Pengajian Tinggi.

**Published by:**

Politeknik Port Dickson,  
KM 14, Jalan Pantai, 71050 Si Rusa, Port  
Dickson, Negeri Sembilan.

September 2024

# ACKNOWLEDGEMENT



**PATRON**      **Hasan Bin Mohd Sharif B.C.M, P.J.K**  
Director, Politeknik Port Dickson

**ADVISORS**    **Ts. Dr. Engku Shahrulerizal bin Engku Ab Rahman**  
Deputy Director (Academic), Politeknik Port Dickson  
**Izwan Kamal bin Abdul Wahab**  
Head of Electrical Engineering Department, Politeknik Port Dickson  
**Azilah binti Asri**  
Head of Electronic Engineering (Communication) Programme,  
Politeknik Port Dickson

**EDITOR**        **Mohamad Zamri bin Muhamad**  
Head of Mathematics and Computer Science Department,  
Politeknik Port Dickson

**FACILITATORS**    **Che Azlina binti Che Norohoseni**  
Mechanical Engineering Department  
**Ahmad Qusyairi bin Ahmad Khairiri**  
Civil Engineering Department

**WRITERS**        **Ts. Fauziah binti Che Mat**  
**Kartheega a/p Shanmugam**  
Electrical Engineering Department

We would like to express our deepest gratitude to a dedicated team of e-book development including the top management team, editor, facilitators, and authors who invested their time and expertise in crafting the content of this e-book.

A special thank you goes to the Department of Polytechnic and Community College Education, particularly the e-Learning and Instructional Division for funding our e-book project.

To everyone who contributed to this e-book in any capacity, we extend our heartfelt thanks. Your collaboration and support have made this e-book successfully developed.





# PREFACE



The study of electric circuits is fundamental to modern electrical engineering and technology. Electric circuits are central to nearly every technological advancement, from powering our homes to operating machinery and driving the digital world. The aim of this e-book is to provide students with a basic understanding of the principles of electric circuits.

This e-book is designed as an introductory resource for polytechnic students starting their journey into electrical engineering. It is also suitable for students from other disciplines who seek to gain a clear understanding of electric circuits. The content covers essential concepts such as voltage, current, and resistance, providing a solid foundation in electric circuit theory.

Each topic is supplemented with clear explanations, examples, and exercises for students to complete at the end of the topic. These features are intended to strengthen comprehension and reinforce learning.

We sincerely hope that this e-book will serve as a valuable resource for polytechnic students in their academic studies and future careers.





# TABLE OF CONTENTS



TOPIC	PAGE
<b>Electric Safety Overview</b> <ul style="list-style-type: none"><li>• The Effects of Electric Current to the Body</li></ul>	1 - 2
<b>Basics of Electricity</b> <ul style="list-style-type: none"><li>• Atom</li><li>• Electricity Conduction</li></ul>	3 - 4
<b>Introduction to Electric Circuit</b> <ul style="list-style-type: none"><li>• Standard Symbol for Electrical Components</li><li>• Cells and batteries</li></ul>	5 - 10
<b>Electric Current</b> <ul style="list-style-type: none"><li>• Main Effect of Electric Circuit</li><li>• Resistance &amp; resistivity</li><li>• Resistor</li></ul>	11 - 15
<b>Ohm's Law</b> <ul style="list-style-type: none"><li>• Series Circuit</li><li>• Voltage Divider Rule (VDR)</li><li>• Parallel Circuit</li><li>• Current Divider Rule (CDR)</li></ul>	16 - 35
<b>Star-Delta Transformation</b>	36- 40
<b>Electrical Power &amp; Energy</b>	41-43
<b>Recap</b>	44



# Electric Safety Overview



## 1) Disconnect the power and always never work on energized circuit

### 3 Basic steps to make sure that the power has been disconnected:-

- i. Test the meter on live circuit just to make sure that the meter works well
- ii. Then, turn off the power and use the meter to test to ensure that it power has been disconnected.
- iii. Test the meter again on a live circuit to ensure once again that the meter operates well.

*Note: It is advisable to hang a warning tag or a install a locking system that informs people not to turn on the power accidentally.*

## 2) Think and always think before act.

Think before acting. Do not solely depend on circuit breakers and fuses instead always test it before touching it. For high voltage equipment, wear protecting clothing such as insulated gloves and meter probes for measure the voltages. **Think before touch** could save life!



## Safety Devices

### Ground Fault Circuit Interrupters

- Ground Fault Circuit Interrupters (GFCI) can help **prevent** electricians from being **electrocuted**.
- The working principle of GFCI is by sensing the difference on amount of current flowing through live and neutral.

### Arc-Fault Circuit Interrupters

- This is similar to the one above, but the Arc - Fault Circuit Interrupters are designed to **protect against fire**.
- Sources of studies have indicated that electrical fire is mostly caused by arc-fault condition.



## 3) No Horseplay

No horseplay in a place with moving machinery and when working on electrical equipment.

This could **cause injury** be it on oneself or a buddy.

## 4) Don't work alone. Have a buddy system.

It is advisable to **work with a buddy** who can call for help in an emergency. Having a buddy system can help to turn off the power and perform **immediate CPR** if he/she is a trained first aider. Some electric shock may result if breathing difficulties and heart fibrillation.

## 5) Use the one-hand technique

The current can travel from one hand to the other which allows the **current to pass through the heart** which results in high **risk to death**. Ironically, a person may survive severe electric shock between hand and foot.

## Types of PPE

### Gloves

Wear leather gloves with rubber inserts when working with energized circuits. Gloves are normally rated for a certain amount of voltage

Always check the condition of the gloves before wearing. Make sure no holes and tearing

### Class C fires

- Fires are divided into 4 classes which are Class A, Class B, Class C and Class D.
- Class C fires are due to electrical equipment.
- The main source of electrical fire is due poor connections.
- Class C fires can be extinguished using dry powder
- Extinguisher ABC can be used for all three types of fire
- it can be fatal if use Class A extinguisher/ water into fire caused by electricity.

# The Effects of Electric Current to the Body

- Many have the opinion that only the current kills people.
- Yes, this is true, but let's not forget that the voltage can harm people too.
- Voltage resembles a force that pushes out the current similar to the way the pressure gushes out water in a pipe.
- The voltage and current depend on the resistance.
- Therefore, the current that can pass through the body is also very much dependent on our body's resistance.
- Everybody has a different resistance in our body.
- Thus, the tolerance of current one people can take is different then the other.
- Similarly, if a person sweats on hot day can have less resistance due to presence of salty sweats that act as a conductor.
- Even body resistance can differ on the type of food one eats and drinks for the day.

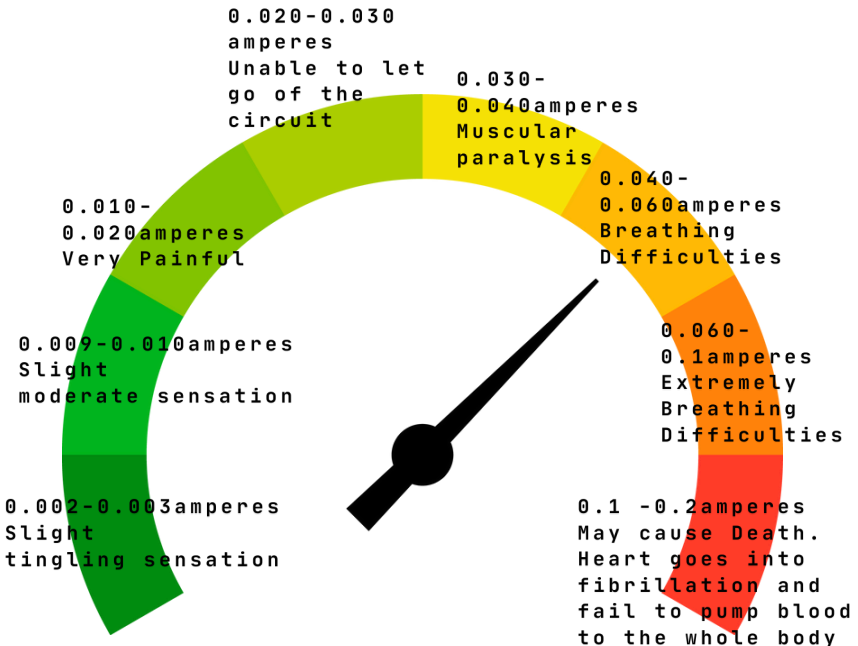

# Basics of Electricity

## Atom

All Matter/ substance are made of atoms.

This means that the atom is the smallest part of any substance.

Atoms are formed by three parts:

Proton :  
positive charge

Electron :  
negative charge

Neutron :  
no charge

Atomic number of atom =  
number of protons.

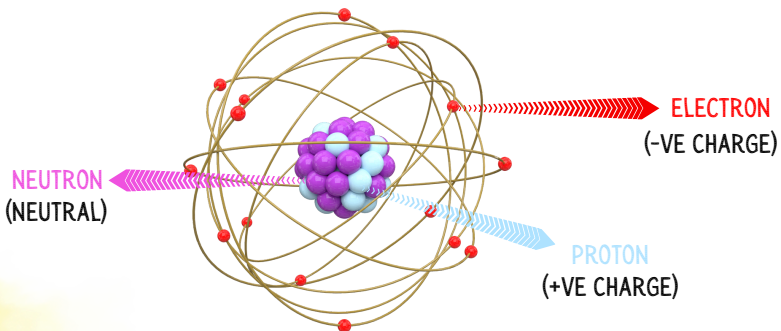

## ● Electricity Conduction

Electron Valence:  
Electron located in most  
outer shell in atom

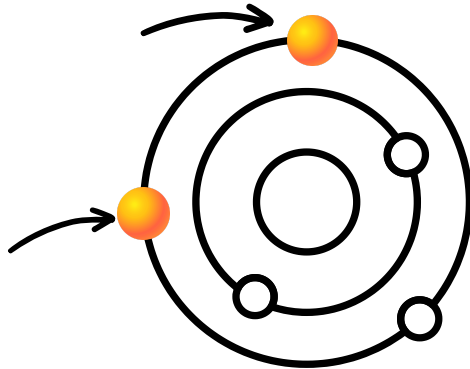

### Conductor

- Flow of electrons is known as electricity.



- A conductor normally contains 1 to 3 electron valence.















- When atoms have few electron valences such as 2 or 3 electron valences, the bonding towards the atom is very loose.



- So, it is easier to escape out and become current.

# Introduction to Electric Circuit

## Standard **Symbol** for Electrical Components

Symbol	Component
	conductor /wire
	switch
	ground/earth
	Cell (dc supply)
	Battery (dc supply)
	AC supply
	resistor
	inductor
	capacitor
	galvanometer
	voltmeter
	ammeter

## Cells and batteries

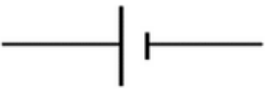
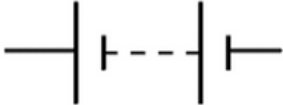
Cell	Battery
A <b>single</b> unit of a primary or secondary battery that converts chemical energy into electric energy.	A battery is a <b>series</b> of two or more connected cells, which changes chemical energy into electrical energy.
	

### Relationship of Cells & Batteries

- A Battery is a combination of cells
- Cell combination could be in SERIES, PARALLEL & SERIES- PARALLEL
- Practically, a cell is also notified as a battery.



### DID YOU KNOW?

Alkaline (Zn/Alkaline/MnO<sub>2</sub>) are the most popular batteries that are used in many regular electronic items because of their moderate cost and high performance



## Series Connection Cells

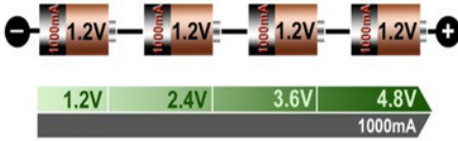

$$\begin{aligned} \text{Total e.m.f., } E_T &= E_1 + E_2 + E_3 + E_4 \\ &= 1.2 + 1.2 + 1.2 + 1.2 \\ &= 4.8\text{V} \end{aligned}$$

$$\begin{aligned} \text{Total current, } I_T &= I_1 = I_2 = I_3 = I_4 \\ &= 1000\text{mA} \end{aligned}$$

## Parallel Connection Cells

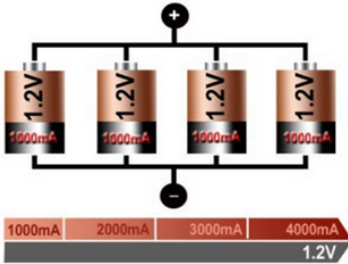

$$\begin{aligned} \text{Total e.m.f., } E_T &= E_1 = E_2 = E_3 = E_4 \\ &= 1.2\text{V} \end{aligned}$$

$$\begin{aligned} \text{Total current, } I_T &= I_1 + I_2 + I_3 + I_4 \\ &= 1000 + 1000 + 1000 + 1000 \\ &= 4000\text{mA} \end{aligned}$$

## Series-Parallel Connection Cells

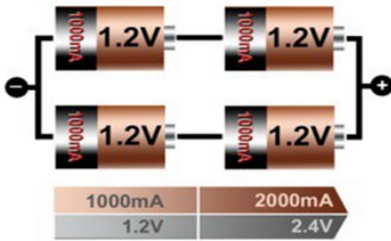

Total e.m.f. for series cells,

$$\begin{aligned} E_{\text{Series1}} &= E_1 + E_2 \\ &= 1.2 + 1.2 \\ &= 2.4\text{V} \end{aligned}$$

$$\begin{aligned} E_{\text{Series2}} &= E_3 + E_4 \\ &= 1.2 + 1.2 \\ &= 2.4\text{V} \end{aligned}$$

$$\text{Total e.m.f., } E_T = E_{\text{Series1}} = E_{\text{Series2}} = 2.4\text{V}$$

Total current for series cells,

$$I_{\text{Series1}} = I_1 = I_2 = 1000\text{mA}$$

$$I_{\text{Series2}} = I_3 = I_4 = 1000\text{mA}$$

$$\begin{aligned} I_T &= I_{\text{Series1}} + I_{\text{Series2}} \\ &= 1000\text{mA} + 1000\text{mA} \\ &= 2000\text{mA} \end{aligned}$$

### GOOD TO REMEMBER!

In series: **voltage is additive**  
**and current is constant**

In parallel: **current is additive**  
**and voltage is constant**



## Example

1. Calculate total e.m.f. of the circuit below

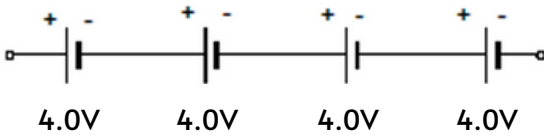

**Solution:-**

$$\begin{aligned}\text{Total e.m.f., } E_T &= E_1 + E_2 + E_3 + E_4 \\ &= 4.0 + 4.0 + 4.0 + 4.0 \\ &= 16\text{V}\end{aligned}$$

2. Calculate total e.m.f. of the circuit below

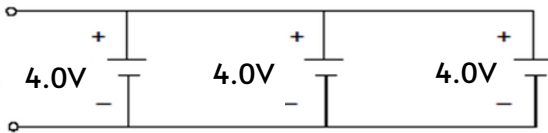

**Solution:-**

$$\text{Total e.m.f., } E_T = E_1 = E_2 = E_3 = 4.0\text{V}$$

3. Calculate total e.m.f. of the circuit below

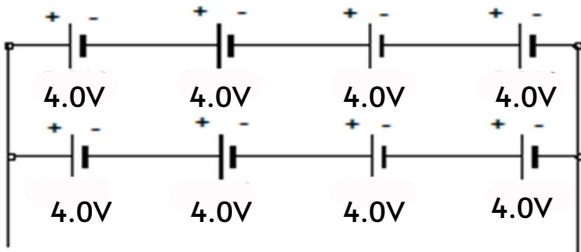

**Solution:-**

$$\begin{aligned}\text{Total e.m.f. for series cells, } E_{\text{Series}} &= E_1 + E_2 + E_3 + E_4 \\ &= 4.0 + 4.0 + 4.0 + 4.0 \\ &= 16\text{V}\end{aligned}$$

$$\text{Total e.m.f., } E_T = E_{\text{Series}} = 16\text{V}$$

4. Calculate total e.m.f. of the circuit below

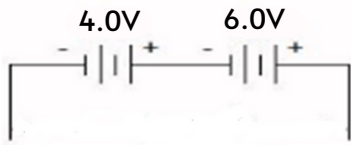

**Solution:-**

$$\begin{aligned}\text{Total e.m.f., } E_T &= E_1 + E_2 \\ &= 8 + 6 \\ &= 14\text{V}\end{aligned}$$

5. Calculate total e.m.f. of the circuit below

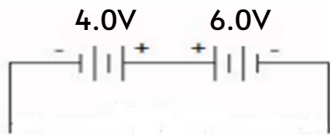

**Solution:-**

$$\begin{aligned}\text{Total e.m.f., } E_T &= E_1 + E_2 \\ &= 6 - 4 \\ &= 2\text{V}\end{aligned}$$



### SELF-EXERCISE

Calculate total e.m.f. of each cells connection as follow:

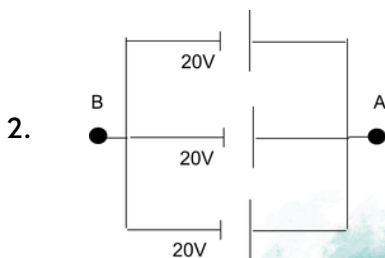
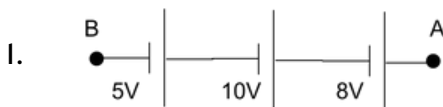

3.

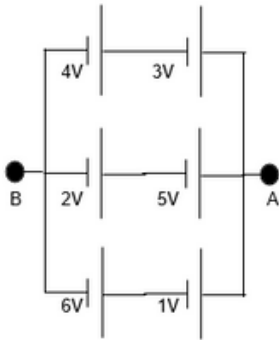

4.

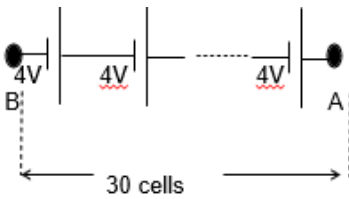

5.

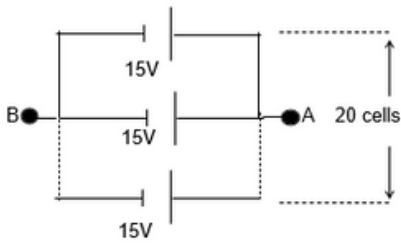

6.

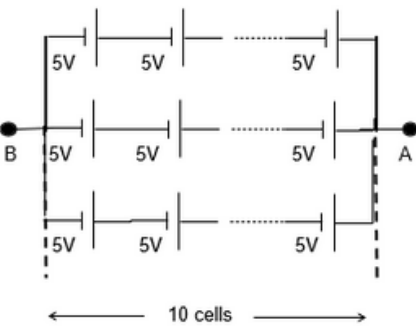

## Electric Current

**Current**

Depends on the speed of electron/charge

Unit: Ampere

$$I = \frac{dq}{dt}$$

$dq$  = changing of charge

$dt$  = changing of time

$I$  = current (ampere)

For steady state condition:

$$I = \frac{Q}{t}$$

Thus,  $Q = It$

$Q$  = charge (coulomb)

$t$  = time (second)

### Example

If a current of 5 A flows for 2 minutes, find the charge transferred.

Solution:-

$$Q = It = 5 \times 2 \times 60 = 600 \text{ C}$$

## Main Effect of Electric Circuit

Chemical Effect

Example: cell and battery

Heat Effect

Example: soldering iron, water heater, fuse, bulb

Magnetic Effect

Example: bells, relays, motors, generators, transformers

**DID YOU KNOW?**

It's not the voltage that kills, it's **current!**



## Resistance & resistivity

**Resistance** → Property of a component that restricts the flow of electric current.

**Resistivity** → The measure of how much a material resists the flow of charges. Different materials have different resistivities.

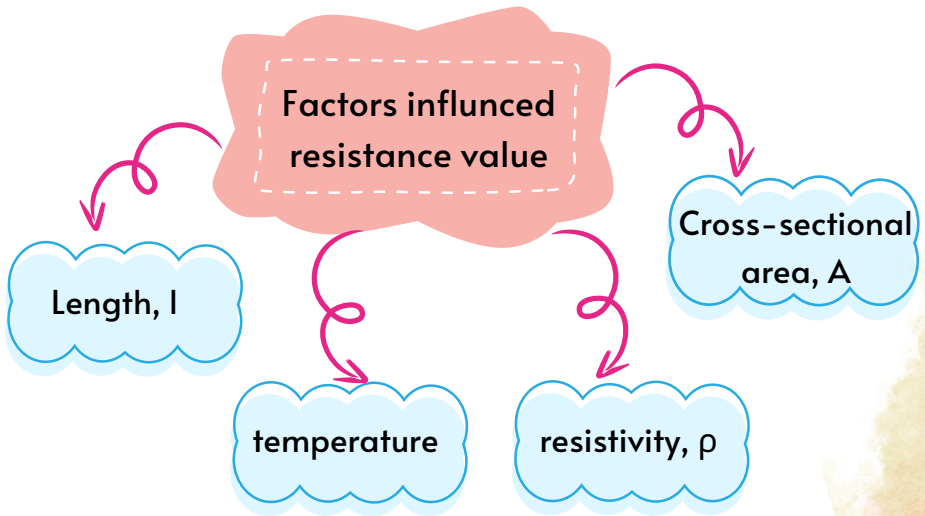

$$R = \frac{\rho l}{A}$$

[Unit =  $\Omega$ ]

R = resistance [ $\Omega$ ]

l = Length [m]

A = Cross-sectional area [ $\text{m}^2$ ]

$\rho$  = resistivity [ $\Omega \cdot \text{m}$ ]

# Resistor (R)



Component



Symbol

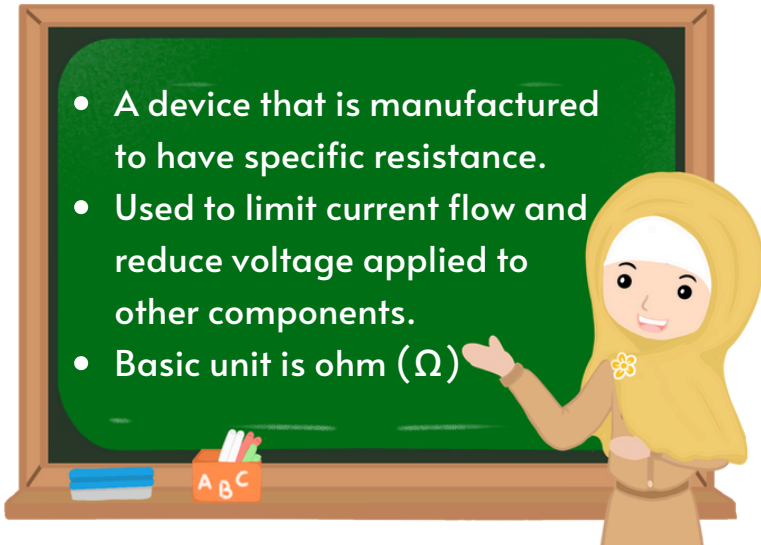

- A device that is manufactured to have specific resistance.
- Used to limit current flow and reduce voltage applied to other components.
- Basic unit is ohm ( $\Omega$ )

## Example

Calculate resistance of a 5m long conductor if it has cross-sectional area  $10\text{mm}^2$  and resistivity  $0.3 \times 10^{-5} \Omega\cdot\text{m}$

**Solution:-**

$$\begin{aligned}\text{Resistance, } R &= \frac{\rho l}{A} = \frac{0.3 \times 10^{-5} \times 5}{10 \times 10^{-6}} \\ &= 1.5\Omega\end{aligned}$$

## SELF-EXERCISE

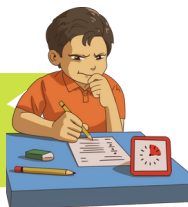

1. In what time would a current of  $1\text{ A}$  transfer a charge of  $30\text{ C}$ ?
2. What would be the resistivity of  $2\text{ m}$  length conductor wire if the resistance value is  $500\Omega$  and the cross sectional area  $0.5\text{ mm}^2$ ?

# Ohm's Law



Discovered by Georg  
Simon Ohm in 1827



$$I = \frac{V}{R}$$

Ohm's Law states that the **current (I)** through a conductor between two points is directly proportional to the potential difference or **voltage (V)** across the two points, and inversely proportional to the **resistance (R)** between them.

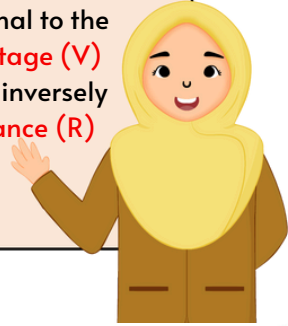

Quantity	Symbol	Unit of Measurement	Unit Abbreviation
Current	I	Ampere ("Amp")	A
Voltage	E or V	Volt	V
Resistance	R	Ohm	Ω

## SIMPLE CIRCUIT

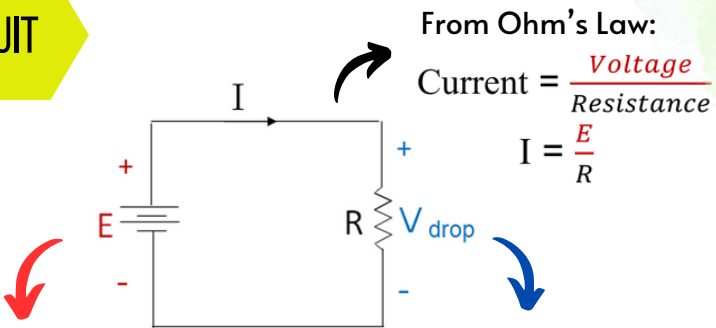

From Ohm's Law:

$$\text{Current} = \frac{\text{Voltage}}{\text{Resistance}}$$

$$I = \frac{E}{R}$$

**E = E.M.F. (Electromotive force)**

- Generates from voltage source
- Example: cells / batteries

**V drop = Voltage drop**

- appears when current, I flows through resistor, R
- Inverse polarity from E

**Voltage = Current x Resistance**

$$V_{\text{drop}} = IR$$

## SIMPLE CIRCUIT

A complete circuit should consist of at least 1 electricity source (battery) and 1 load (resistor)

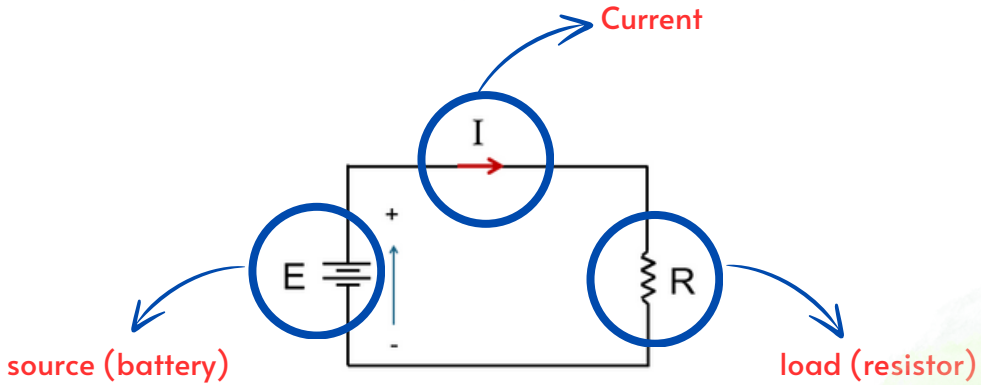

Current will only produce when the source (battery) is connected to the load (resistor) in close loop connection.

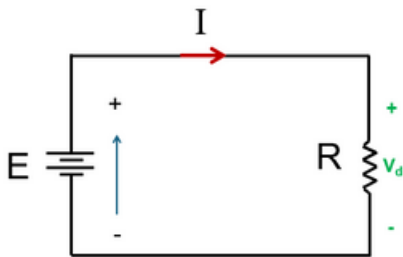

When current flows across resistor, R, voltage drop,  $V_d$  will be produced across R

## Example

By referring to the circuit below, calculate:

- Current,  $I$
- Voltage drop across resistor  $10\Omega$ ,  $V_{\text{drop}}$

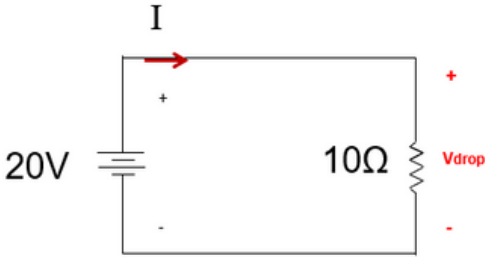

**Solution:-**

i) Current,  $I = \frac{V}{R} = \frac{20}{10} = 2A$

ii) Voltage drop,  $V_{\text{drop}} = IR = 2 \times 10 = 20V$

## Series Circuit

Is formed when any number of devices are connected end-to-end so that there is only one path for current to flow.

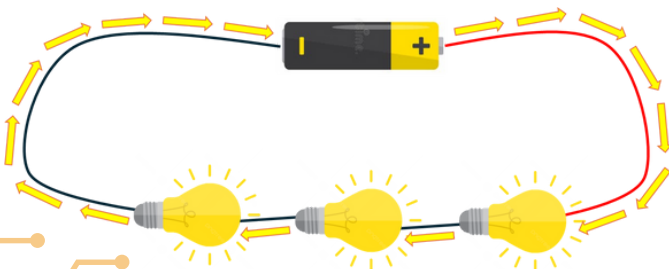

## Series Circuit Characteristics

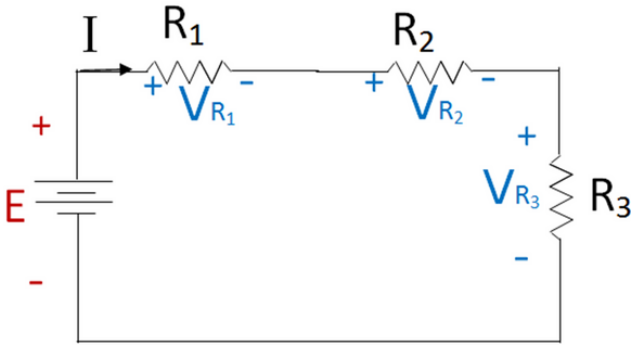

1. Resistances are additive

$$R_T = R_1 + R_2 + R_3$$

2. The current flows throughout the circuit is same

$$I = IR_1 = IR_2 = IR_3$$

3. Different resistors have their individual voltage drop

$$V_{R_1} \neq V_{R_2} \neq V_{R_3}$$

4. Total e.m.f equals to the sum of voltage drops across each resistor

$$E = V_{R_1} + V_{R_2} + V_{R_3}$$



## Equivalent resistance in series

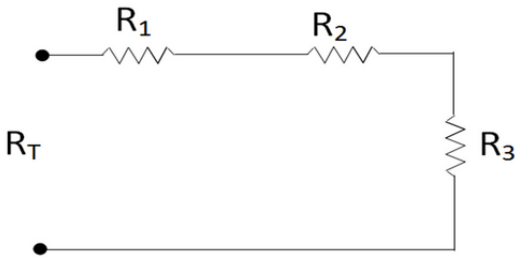

$$R_T = R_1 + R_2 + R_3$$

- Applicable to any means of resistors.
- Standard equation of series connection resistors.

## Resistors with same value

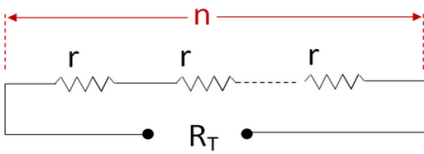

$$R_T = r \times n$$

- $r$  = resistance value  
 $n$  = amount of resistors

## Voltage Divider Rule (VDR)

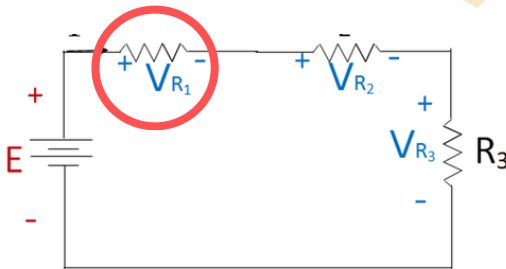

$$V_{R1} = \frac{R_1}{R_1 + R_2 + R_3} \times E$$

## Example



By referring to the circuit below, calculate:

i) Total resistance of the circuit,  $R_{\text{total}}$

ii) Current,  $I$

Voltage drop across resistor  $6\ \Omega$

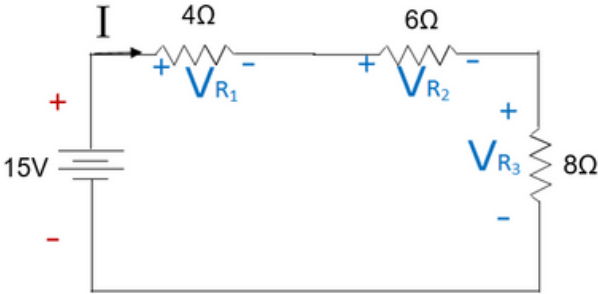

**Solution:-**

i)  $R_{\text{total}} = 4 + 6 + 8 = 18\ \Omega$

ii)  $I = \frac{E}{R} = \frac{15}{18} = 0.833\text{A}$

iii)  $V_{R2} = IR2 = 0.833 \times 6 = 5\text{V}$

or use VDR

$$\begin{aligned} V_{R2} &= \frac{R_2}{R_1 + R_2 + R_3} \times E \\ &= \frac{6}{4 + 6 + 8} \times 15 = 5\text{V} \end{aligned}$$

# Parallel Circuit

Is formed when two or more devices are arranged in a circuit side by side so that current can flow through more than one path

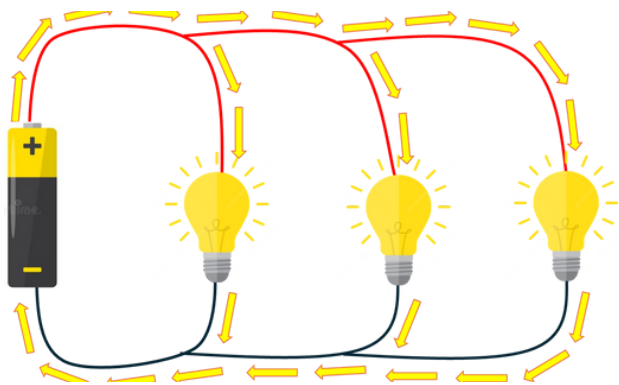

## Parallel Circuit Characteristic

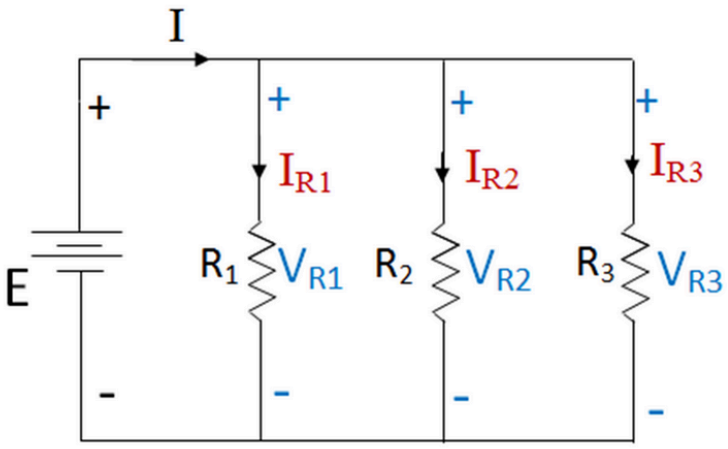

1. Total resistance can be determined from:

$$R_T = \frac{1}{\frac{1}{R_1} + \frac{1}{R_2} + \frac{1}{R_3}}$$

2. Different resistors have their individual current.

$$IR_1 \neq IR_2 \neq IR_3$$

3. Same voltage acts across all parts of the circuit

$$E = VR_1 = VR_2 = VR_3$$

4. Supplied current equals to the sum of different current flows through each resistor.

$$I = IR_1 + IR_2 + IR_3$$

### Equivalent resistance in parallel

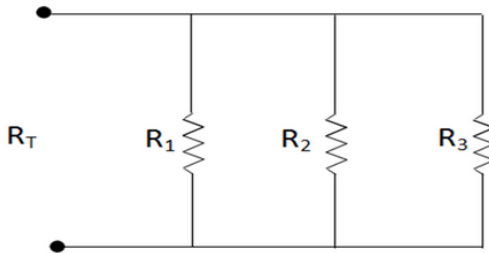

$$R_T = \frac{1}{\frac{1}{R_1} + \frac{1}{R_2} + \frac{1}{R_3}}$$

- Applicable to any means of resistors.
- Standard equation of parallel connection resistors.

### 2 resistors case

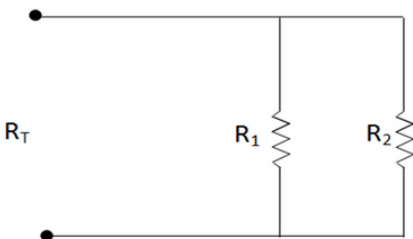

$$R_T = \frac{R_1 \times R_2}{R_1 + R_2}$$

- Applicable for 2 resistors connection only

## Same value case

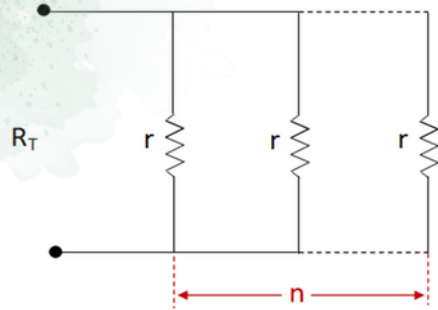

$$R_T = \frac{r}{n}$$

$r$  = resistance value

$n$  = amount of resistors

- Applicable for any means of resistors with same value

## Current Divider Rule (CDR)

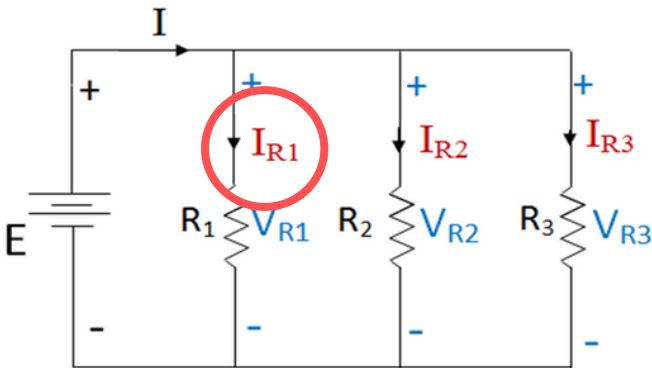

$$I_{R1} = \frac{\frac{1}{R_1}}{\frac{1}{R_1} + \frac{1}{R_2} + \frac{1}{R_3}} \times I$$

- Applicable to any means of resistors.
- Standard equation of current divider rule

## 2 Resistors case

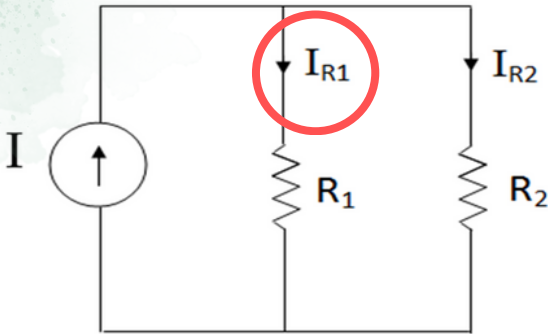

$$I_{R1} = \frac{R_2}{R_1 + R_2} \times I$$

- Applicable for 2 resistors connection only

## Example

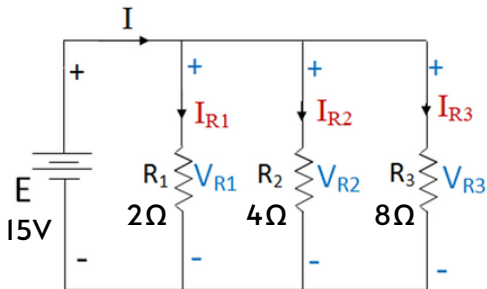

- By referring to the circuit, calculate:
- Total resistance of the circuit,  $R_{total}$
  - Current,  $I$
  - Voltage drop across resistor  $8\Omega$
  - Current through resistor  $2\Omega$

$$i) \quad R_{total} = \frac{1}{\frac{1}{2} + \frac{1}{4} + \frac{1}{8}} = 1.143\Omega$$

$$ii) \quad I = \frac{E}{R} = \frac{15}{1.143} = 13.12A$$

$$iii) \quad V_{R3} = E = 15V$$

$$iv) \quad I_{R1} = \frac{V}{R} = \frac{15}{2} = 7.5A$$

or use CDR

$$I_{R1} = \frac{\frac{1}{2}}{\frac{1}{2} + \frac{1}{4} + \frac{1}{8}} \times 13.12 = 7.5A$$

## Series-Parallel Circuit

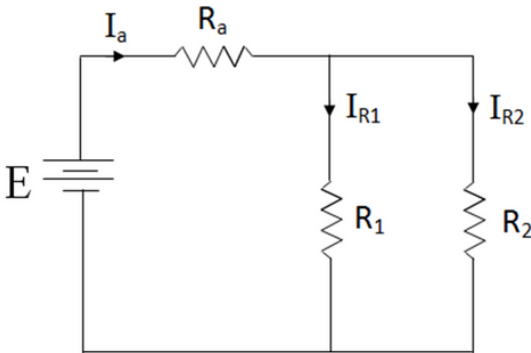

- $R_1$  is parallel with  $R_2$ .
- $R_a$  is series with equivalent resistance of  $R_1$  and  $R_2$ .

### Total Resistance of Series-Parallel Circuit

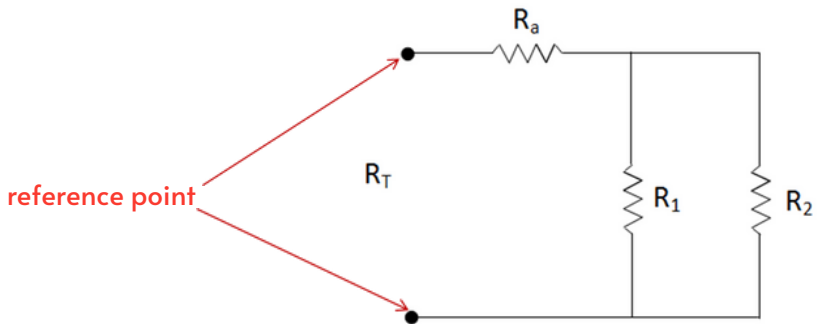

- $R_T$  is the equivalent resistance of  $R_a$ ,  $R_1$  and  $R_2$
- Start solving by calculating the total resistance of parts located farthest away from the reference point.

### Exception:

if there are any series/parallel connection resistors at any part of circuit which is not farthest from the reference point, solve the total resistance of the series/parallel connection first. Then you can use the tips mentioned above to solve your problem.

## Example

Calculate equivalent resistance,  $R_T$  of the circuit below.

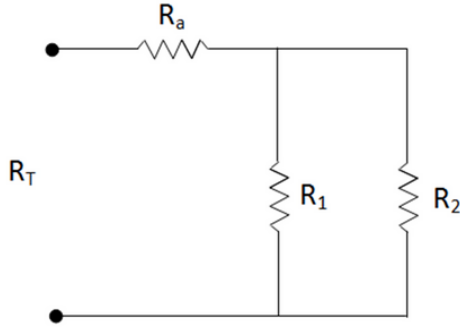

**Solution:**

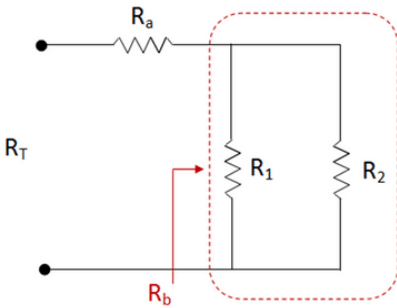

Step 1:

- Solve parallel connection  $R_1$  and  $R_2$
- Name as  $R_b$

$$R_b = \frac{R_1 \times R_2}{R_1 + R_2}$$

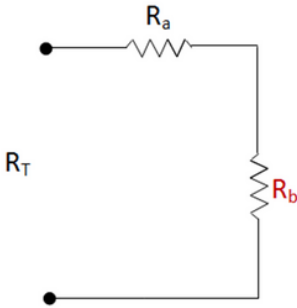

Step 2:

- Solve series connection  $R_a$  and  $R_b$

$$R_T = R_a + R_b$$

## Example

Calculate the total resistance,  $R_T$  of the circuit below

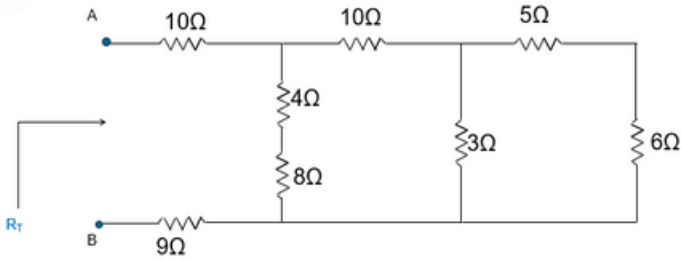

**Solution:**

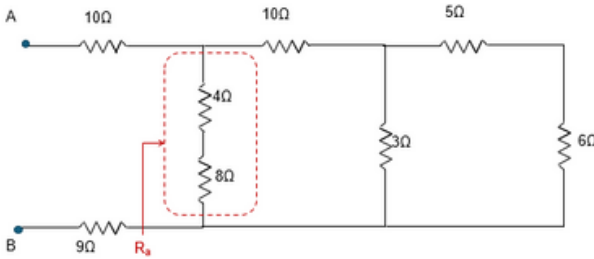

### Step 1:

Identify any series/parallel connection (in between) and calculate the total resistance

$$R_a = 4 + 8 = 12\Omega$$

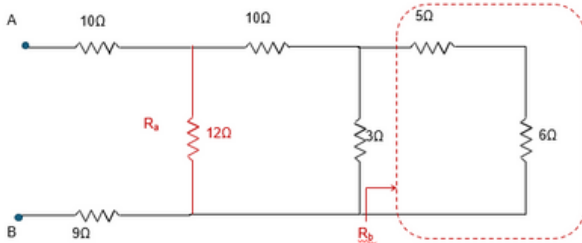

### Step 2:

Identify the farthest part from ref. point and calculate the total resistance.

$$R_b = 5 + 6 = 11\Omega$$

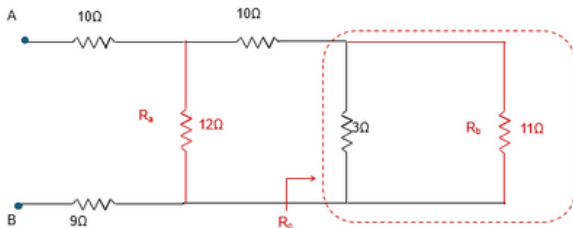

### Step 3:

calculate the total resistance of next portion until reach ref. point.

$$R_c = \frac{3 \times 11}{3 + 11} = 2.36\Omega$$

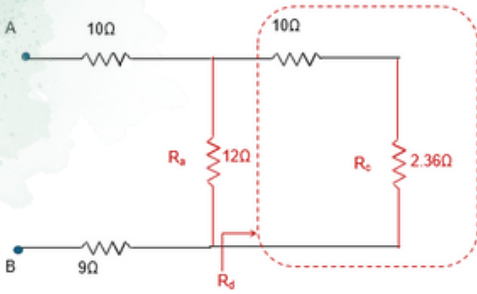

Repeat Step 3 until reach ref. point.

$$R_d = 10 + 2.36 = 12.36\Omega$$

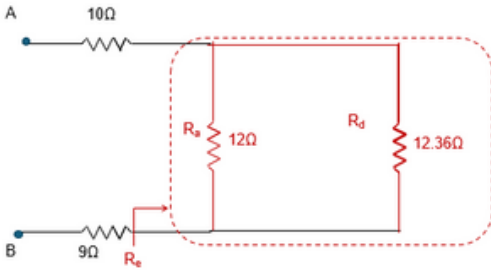

$$R_e = \frac{12 \times 12.36}{12 + 12.36} = 6.09\Omega$$

#### Step 4:

Finally, calculate the total resistance,  $R_T$  of the circuit

$$R_T = 10 + 6.09 + 9 = 25.09\Omega$$

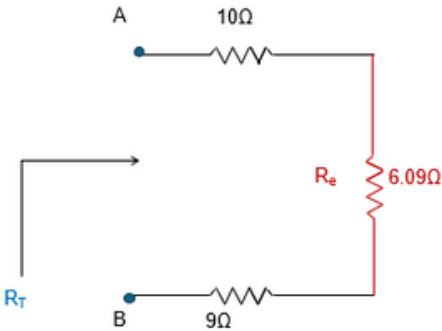

## Example

Calculate the total resistance across point A - B

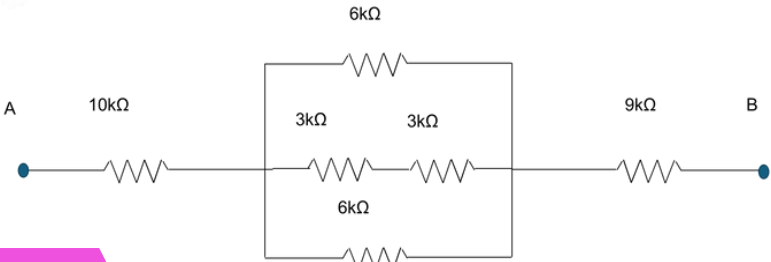

**Solution:**

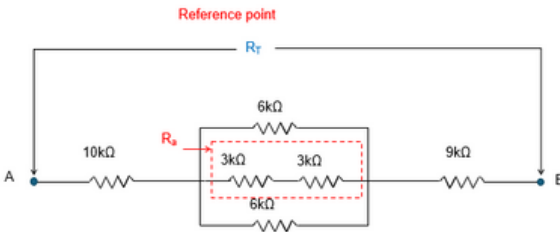

$$R_a = 3k + 3k = 6k\Omega$$

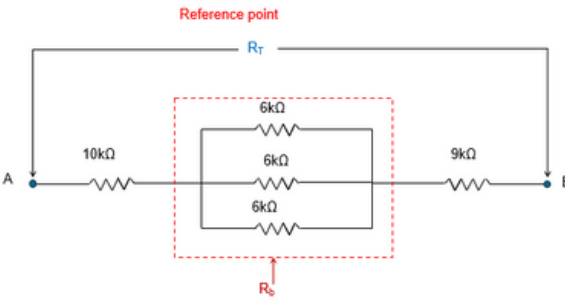

$$R_b = \frac{6k}{3} = 2k\Omega$$

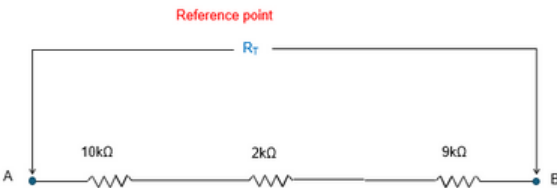

$$R_T = 10k + 2k + 9k = 21k\Omega$$

## Example

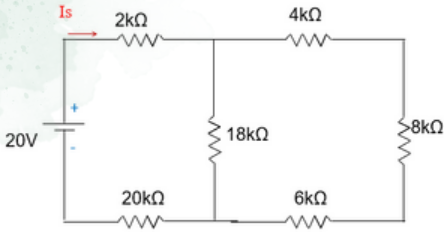

### QUESTION:

- By referring to the circuit given, calculate:
- i) Equivalent resistance of the circuit,  $R_{total}$
  - ii) Current from supply,  $I_s$
  - iii) Current through resistor  $18k\Omega$
  - iv) Voltage drop across resistor  $8k\Omega$

### Solution:

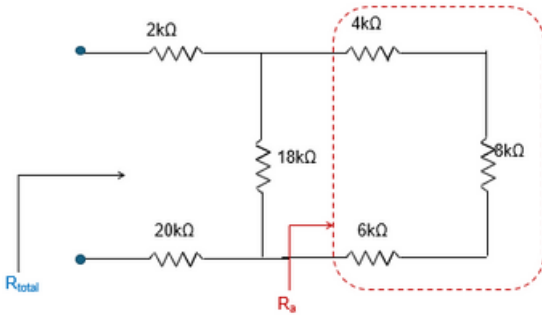

#### i) Total Resistance:

- Temporarily, remove voltage source from the circuit.
- The open nodes leaved by your voltage source would be your reference point

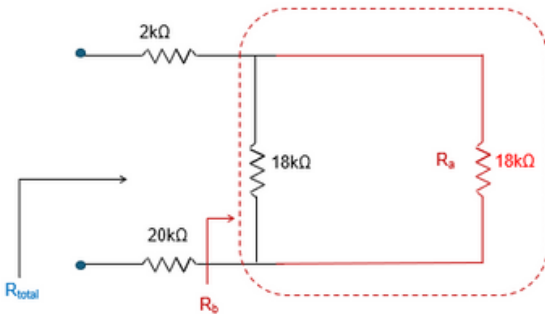

$$R_a = 4k + 8k + 6k = 18k\Omega$$

$$R_b = \frac{18k}{2} = 9k\Omega$$

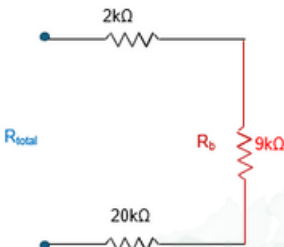

$$R_{total} = 2k + 9k + 20k = 31k\Omega$$

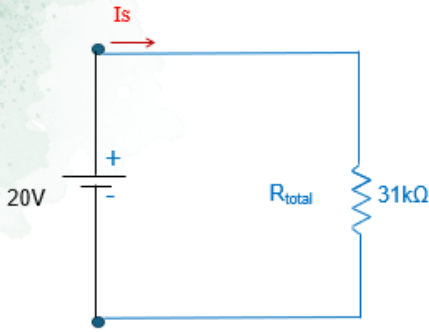

ii) Supply current :

- Place voltage source back to the circuit.
- Current from source is calculated using Ohm's Law

$$I_s = \frac{E}{R} = \frac{20}{31k} = 645.16\mu A$$

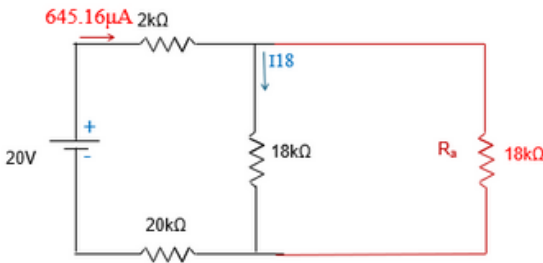

iii) Current through 18kΩ resistor:

Use current divider rules (CDR) or any other relevant methods

If Use CDR:

$$I_{18} = \frac{18k}{18k + 18k} \times 645.16\mu$$

$$= 322.58 \mu A$$

Other method:

$$I_{18} = \frac{645.16\mu}{2} = 322.58\mu A$$

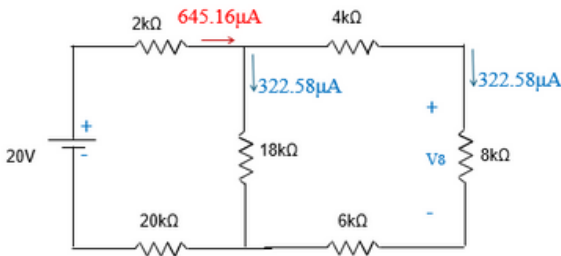

iv) Voltage drop across 8kΩ resistor:

- Calculate the current flows through 8kΩ resistor first
- Use Ohm's Law to calculate the Voltage drop
- Other method : Voltage Divider Rule (VDR)

$$I_8 = 645.16\mu - 322.58\mu = 322.58 \mu A$$

$$V_8 = IR = 322.58\mu \times 8k = 2.58V$$

## EXERCISE

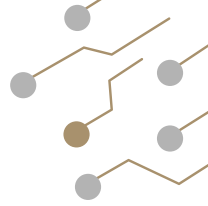

### Question 1

Calculate the total current in the circuit below:

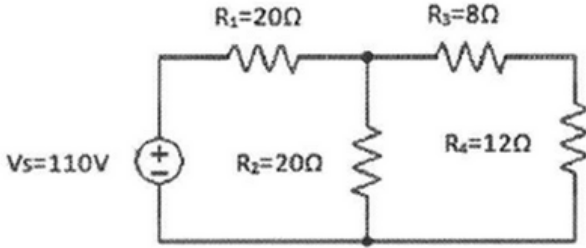

### Question 2

Given that total resistance is  $1.5\text{k}\Omega$ , determine value of  $R_2$  in the circuit below:

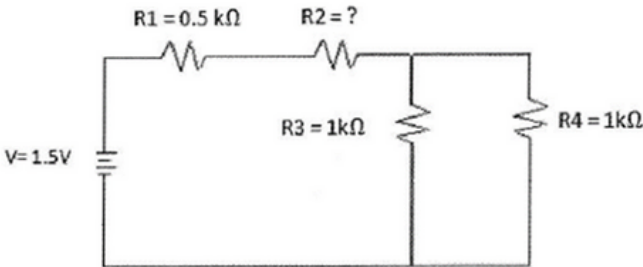

### Question 3

Given that total resistance is  $3\Omega$ . Calculate the value of resistor  $R_1$  and current flow through resistor  $R_1$  by using Current Divider Rule (CDR)

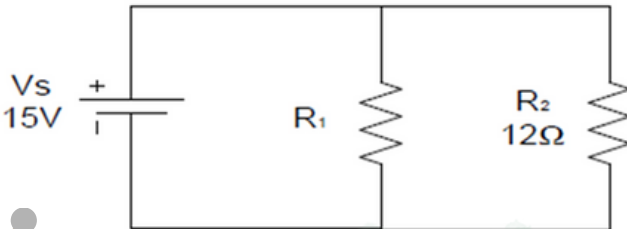

#### ▶ Question 4

Calculate the voltage drop through each resistor in circuit below using Voltage Divider Rule (VDR)

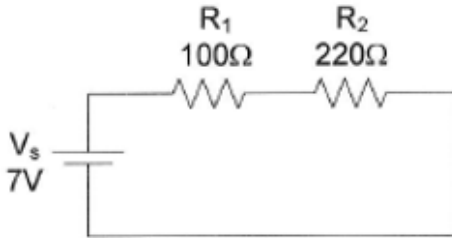

#### ▶ Question 5

Calculate the total resistance and current through each resistor in circuit below:

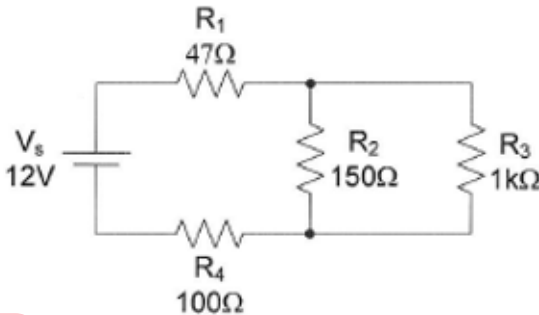

#### ▶ Question 6

Use Voltage Divider Rule to calculate the voltage drop through each resistor in the circuit below:

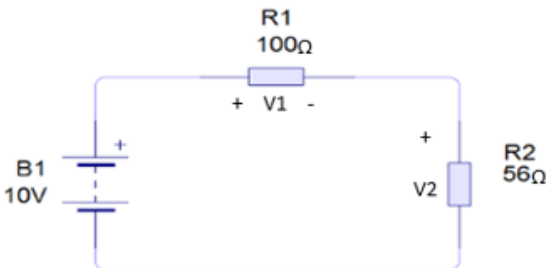

### Question 7

Calculate the total resistance and current through each resistor in the circuit below:

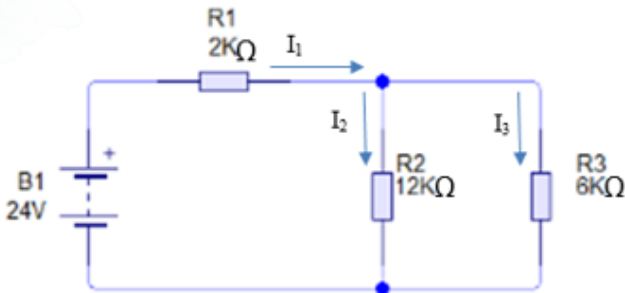

### Question 8

By referring the circuit below, calculate the value of the current flow through 6Ω resistor when the voltmeter shows 18V.

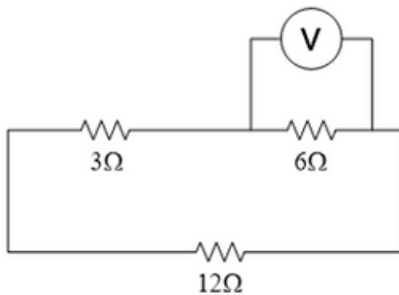

### Question 9

Calculate the current flow through resistor 4Ω using Current Divider Rule.

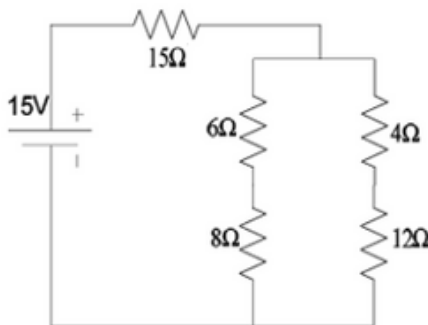

## Delta-Star Transformation

Standard 3-phase circuits or networks take on two major forms with names that represent the way in which the resistances are connected, a Star connected network which has the symbol of the letter,  $\Upsilon$  (wye) and a Delta connected network which has the symbol of a triangle,  $\Delta$  (delta).

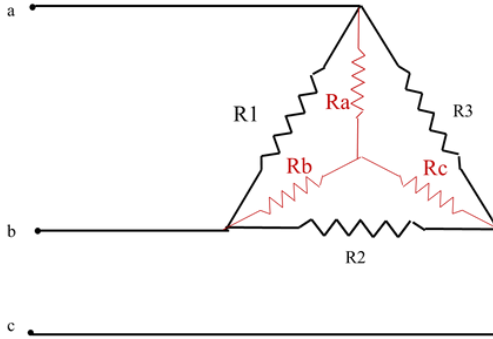

### Delta-Star Transformation

$$R_a = \frac{R_1 \times R_3}{R_1 + R_2 + R_3}$$

$$R_b = \frac{R_1 \times R_2}{R_1 + R_2 + R_3}$$

$$R_c = \frac{R_2 \times R_3}{R_1 + R_2 + R_3}$$

### Star-Delta Transformation

$$R_1 = \frac{(R_a \times R_b) + (R_b \times R_c) + (R_a \times R_c)}{R_c}$$

$$R_2 = \frac{(R_a \times R_b) + (R_b \times R_c) + (R_a \times R_c)}{R_a}$$

$$R_3 = \frac{(R_a \times R_b) + (R_b \times R_c) + (R_a \times R_c)}{R_b}$$

## Example

Calculate the total resistance,  $R_{xy}$  of the circuit below.

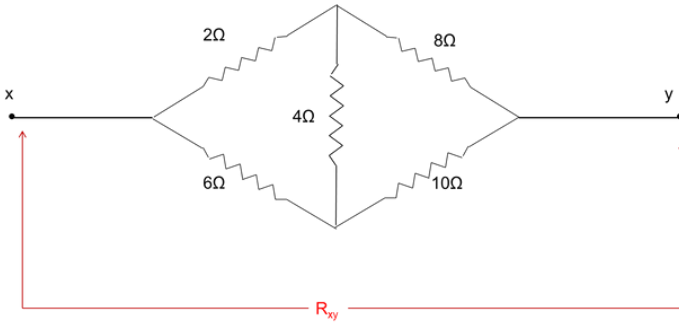

**Solution:**

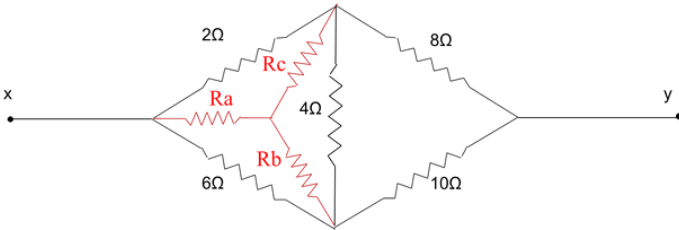

**Convert  $\Delta$  --- Y**

$$R_a = \frac{2 \times 6}{2 + 6 + 4} = 1\Omega$$

$$R_b = \frac{6 \times 4}{2 + 6 + 4} = 2\Omega$$

$$R_c = \frac{2 \times 4}{2 + 6 + 4} = 0.67\Omega$$

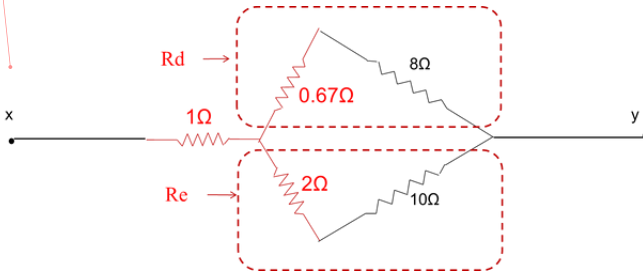

$$R_d = 0.67 + 8 = 8.67\Omega$$

$$R_e = 2 + 10 = 12\Omega$$

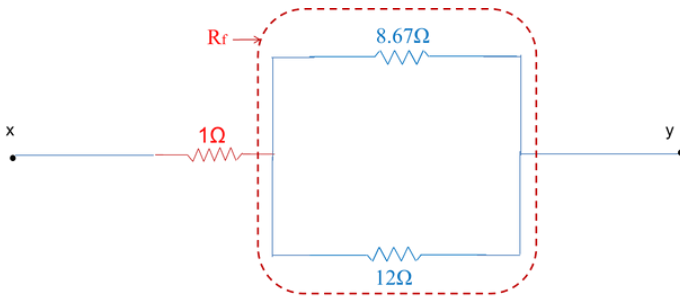

$$R_f = \frac{8.67 \times 12}{8.67 + 12} = 5.02\Omega$$



$$R_{xy} = 1 + 5.03 = 6.03\Omega$$

## EXERCISE



### Question 1

Determine total resistance  $R_T$  by using star-delta transformation on resistor  $10\Omega$ ,  $15\Omega$  and  $8\Omega$  resistors.

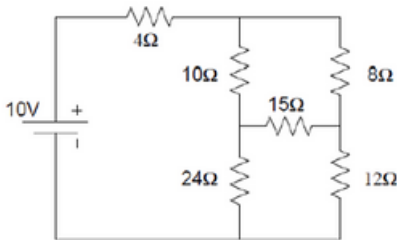

### Question 2

By applying Delta to Star Transformation, calculate the Total Resistance of the circuit below.

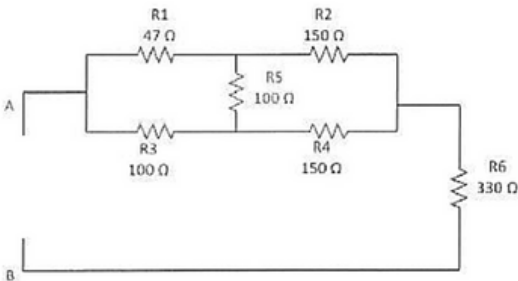

### Question 3

By using Star-Delta Transformation, calculate the total resistance,  $R_t$ .

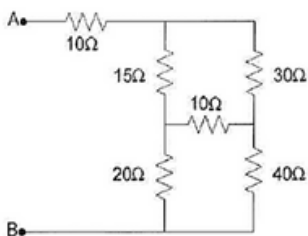

▶ Question 4

Calculate the individual resistance for the star network from delta network as shown below.

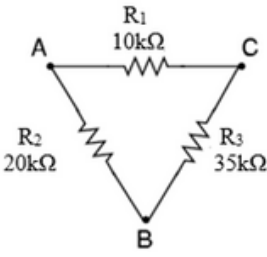

▶ Question 5

Determine the values of  $R_1$ ,  $R_2$  and  $R_3$  as in figure below.

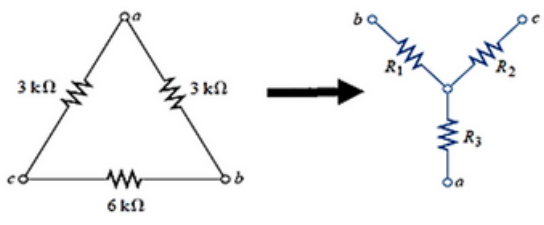

## Electrical Power & Energy

**ELECTRICAL POWER**

defined as the rate at which electrical energy is transferred by an electric circuit

The SI unit of power is **Watt**

Equation:  $P = VI$

V – voltage measured in Volts (V)

I – current measured in Ampere (A)

From Ohm's Law



$$I = \frac{V}{R} \quad \text{and} \quad V = I \times R$$

Hence, Power

$$P = \frac{V^2}{R} \quad \text{or} \quad P = I^2 R$$

**ENERGY**

defined as capacity to do work

The unit of energy is **Joule**

Equation:

$$\text{Energy/Work Done, } W = Pt$$

P – power measured in Watt (W)

t – time measured in seconds (s)

## Example

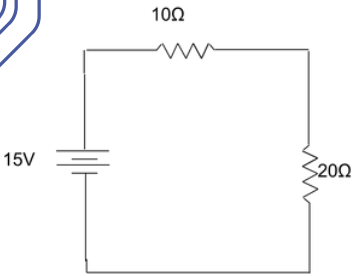

By referring to the circuit given, calculate:

- Power that's supplied by the battery
- Power that's absorbed by 20Ω resistor
- Energy supplied by the battery after 40s
- Energy absorbed by the 10Ω resistor after 3 hours

### Solution:

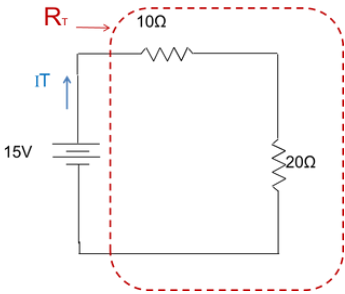

- Power that's supplied by the battery

$$R_T = 10 + 20 = 30\Omega$$

$$I_T = \frac{E}{R} = \frac{15}{30} = 0.5A$$

$$\text{Power, } P_s = V \cdot I = 15 \times 0.5 = 7.5W$$

- Power that's absorbed by 20Ω resistor

$$\text{Power, } P_L = I^2 \cdot R = 0.5^2 \times 20 = 5W$$

- Energy supplied by the battery after 40s

$$\text{Energy, } W = P \times t = 7.5 \times 40 = 300J$$

- Energy absorbed by the 10Ω resistor after 3 hours

Energy,

$$W = P \times t = I^2 \times R \times t$$

$$= 0.5^2 \times 10 \times 3 \times 60 \times 60$$

$$= 27kJ$$

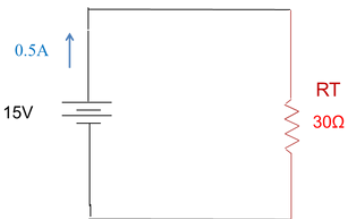

## EXERCISE



### Question 1

Based on circuit below, calculate the power that is absorbed by  $R_3$ .

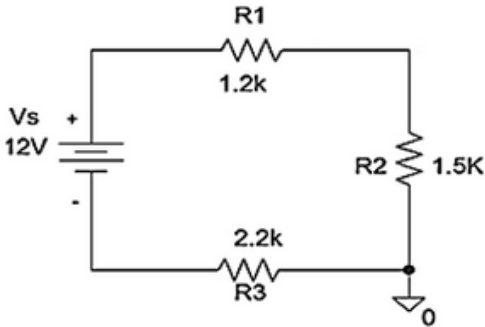

### Question 2

Refer to figure below:

1. calculate the value of current flow through the  $6\Omega$  resistor when the voltmeter shows  $18V$ .
2. explain what will happen to the power dissipated by the  $6\Omega$  resistor if the voltage across it doubles.

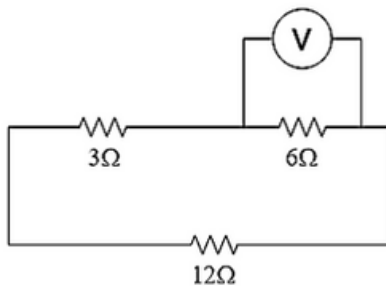

# RECAP

Cell and battery are sources of DC type of electricity.

Voltage, current and resistance are recognized as three basic elements of electrical circuit which contribute in Ohm's Law.

Electrical circuit can be constructed in series, parallel and combination of series-parallel connection.

Star-Delta transformation technique is required to analyze network that involve Star/Delta connection.

Power and Energy is the product of voltage and current elements of a circuit.



Ohm's Law Pie Chart

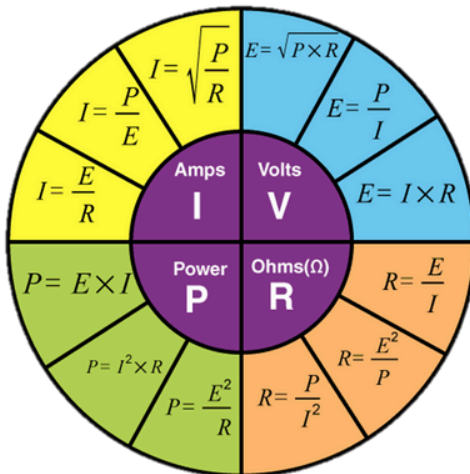

Thank You

# REFERENCES

Aminah, Zulkarnain, Ja'far, Junaida. (2016). Electrical Technology. Shah Alam: Oxford Fajar Bakti.

Tony R. Kuphaldt (2023). Lessons in Electric Circuits (5th edition). <https://www.allaboutcircuits.com/textbook/direct-current/>

Think & Learn Pvt Ltd (2023). Ohm's Law. <https://byjus.com/physics/ohms-law/>

Ashby, D. (2012). Electrical Engineering I01. Oxford, United Kingdom: Elsevier Science & Technology.

Bird, J. (2017). Electrical Circuit Theory and Technology, 6th ed. London, United Kingdom: Taylor & Francis Ltd.

Floyd, T. L. (2019). Principles of Electric Circuits. United States: Pearson Education (US).

Hambley, A. R. (2018). Electrical Engineering: Principles & Applications, Global Edition. Harlow, United Kingdom: Pearson Education Limited.



INTRODUCTION TO ELECTRIC CIRCUIT

e ISBN 978-629-7643-39-7

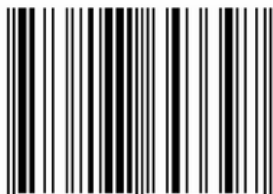

9 786297 643397