

SULIT



**KEMENTERIAN PENDIDIKAN TINGGI
JABATAN PENDIDIKAN POLITEKNIK DAN KOLEJ KOMUNITI**

**BAHAGIAN PEPERIKSAAN DAN PENILAIAN
JABATAN PENDIDIKAN POLITEKNIK DAN KOLEJ KOMUNITI
KEMENTERIAN PENDIDIKAN TINGGI**

JABATAN KEJURUTERAAN AWAM

PEPERIKSAAN AKHIR

SESI I : 2025/2026

DCC40163 : THEORY OF STRUCTURES

TARIKH : 03 DISEMBER 2025

MASA : 2.30 PETANG – 4.30 PETANG (2 JAM)

Kertas soalan ini mengandungi **LIMA BELAS (15)** halaman bercetak.

Bahagian A: Subjektif (2 soalan)

Bahagian B: Subjektif (4 soalan)

Dokumen sokongan yang disertakan : Formula

JANGAN BUKA KERTAS SOALAN INI SEHINGGA DIARAHKAN

(CLO yang tertera hanya sebagai rujukan)

SULIT

SECTION A : 50 MARKS**BAHAGIAN A : 50 MARKAH****INSTRUCTION :**

This section consists of **TWO (2)** subjective questions. Answer **ALL** questions.

ARAHAN :

Bahagian ini mengandungi **DUA (2)** soalan subjektif. Jawab **SEMUA** soalan.

QUESTION 1**SOALAN 1**

- CLO2 (a) Classify the static determinacy of the trusses in Figure A1(a)(i) and Figure A1(a)(ii).

Kelaskan kebolehtentuan statik kekuda dalam Rajah A1(a)(i) dan Rajah A1(a)(ii).

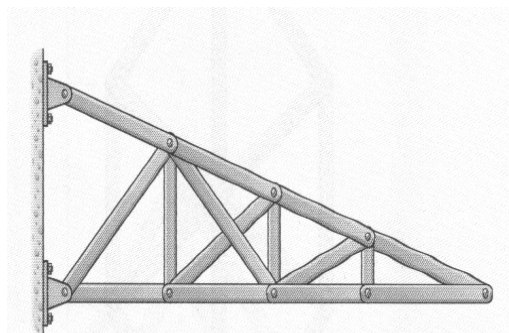
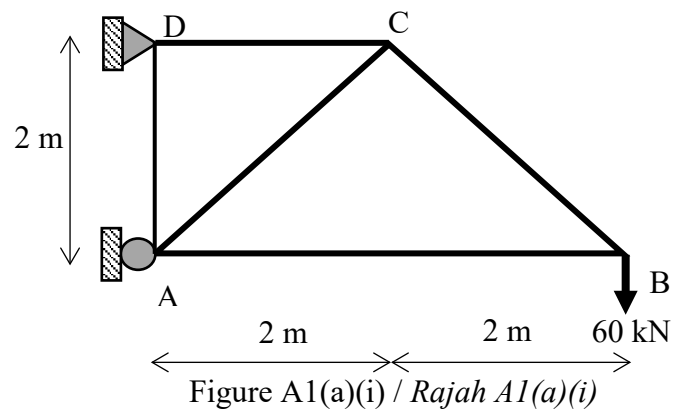

Figure A1(a)(ii) / Rajah A1(a)(ii)

[8 marks]

[8 markah]

- CLO2 (b) A statically determinate truss is subjected to a vertical load at joint C as shown in Figure A1(b)(i). At the same time, Figure A1(b)(ii) shows the internal forces due to a vertical 1 unit load at joint C. Given that the cross-sectional area of each member is 250 mm^2 and the Elastic Modulus is $300 \times 10^6 \text{ kN/m}^2$, determine the vertical displacement at joint C by using the Virtual Work Method.

Sebuah kekuda boleh tentu statik dikenakan beban 50kN secara pugak pada sambungan C di Rajah A1(b)(i). Pada masa yang sama Rajah A1(b)(ii) pula menunjukkan daya dalaman yang diakibatkan oleh beban pugak 1 unit di sambungan C. Diberi luas keratan rentas setiap anggota ialah 250mm^2 dan Modulus Keanjalan ialah $300 \times 10^6 \text{ kN/m}^2$, tentukan anjakan pugak pada sambungan C dengan menggunakan Kaedah Kerja Maya.

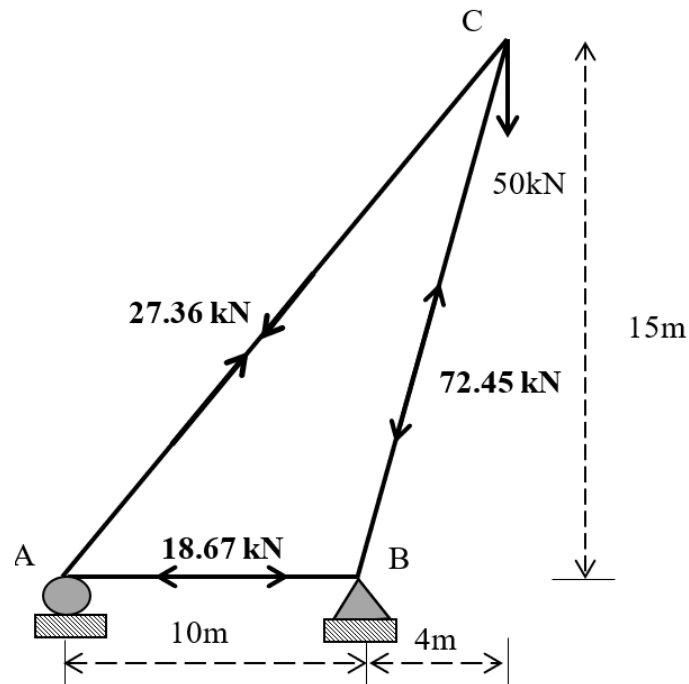

Figure A1(b)(i) / Rajah A1(b)(i)

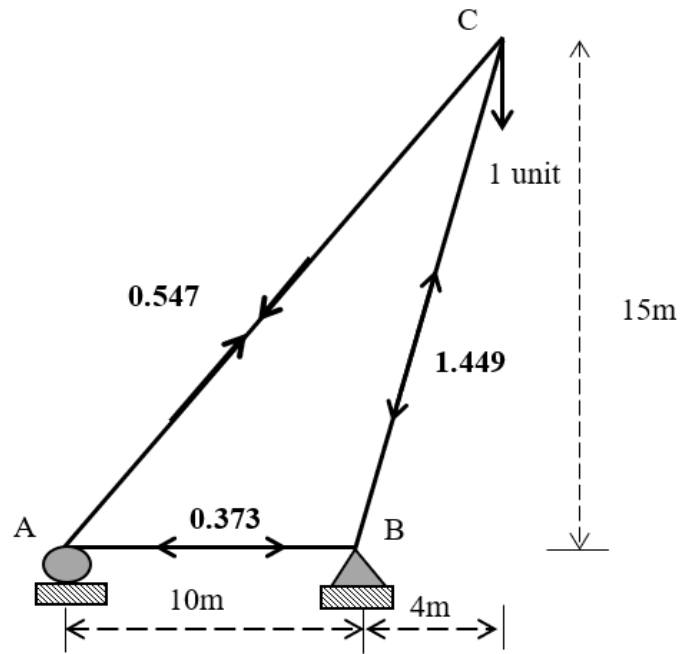

Figure A1(b)(ii) / Rajah A1(b)(ii)

[7 marks]

[7 markah]

- CLO2 (c) Figure A1(c) shows the statically indeterminate trusses. Table A1(c) is the value of actual forces of the trusses. Calculate the redundancy value, R , for the trusses by using the Virtual Work Method. Horizontal reaction at support C is selected as the redundant. Given the cross-sectional area, the Elastic Modulus of the trusses is constant.

Rajah A1(c) menunjukkan kekuda tidak boleh tentu statik. Jadual A1(c) menunjukkan daya dalaman disebabkan oleh beban sebenar. Kirakan nilai lebihan, R dengan menggunakan Kaedah Kerja Maya. Tindak balas secara mengufuk pada penyokong C dipilih sebagai kelebihan. Diberi luas keratan rentas, Modulus Keanjalan, bagi kekuda adalah malar.

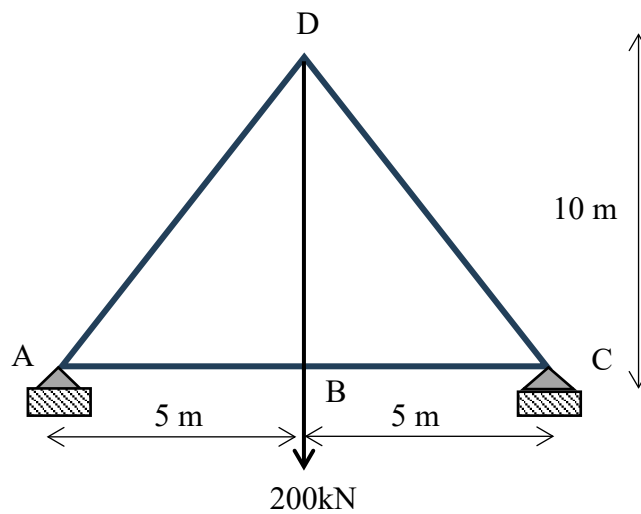

Figure A1(c) / *Rajah A1(c)*

Table A1(c) / *Jadual A1(c)*

| Member <i>Anggota</i> | Internal Force due to actual load, P (kN) <i>Daya dalaman disebabkan oleh Beban Sebenar, P (kN)</i> |
|--------------------------|--|
| AB | +50 |
| AD | -111.80 |
| DB | +200 |
| DC | -111.80 |
| CB | +50 |

[10 marks]

[10 markah]

QUESTION 2

SOALAN 2

CLO3

- (a) A beam is subjected to a series of loads as shown in Figure A2(a). By using Influence Line Diagram Method.

Satu rasuk dikenakan siri beban seperti yang ditunjukkan dalam Rajah A2(a). Dengan menggunakan Kaedah Garis Imbas.

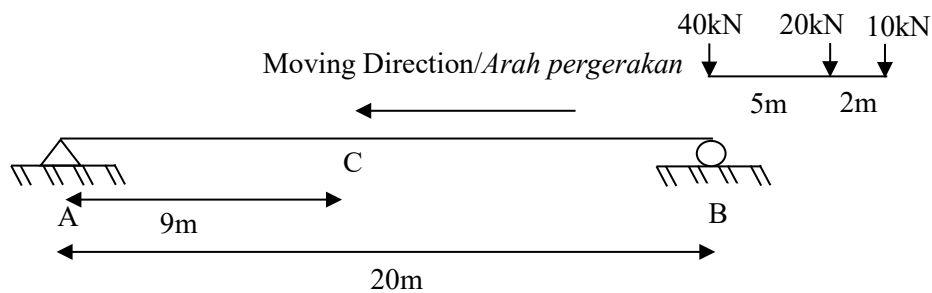

Figure A2(a)/Rajah A2(a)

- i. Illustrate the Influence Line Diagram for shear force and moment at point C.

Lakarkan Gambarajah Garis Imbas daya ricih dan momen pada titik C.

[6 marks]

[6 markah]

- ii. Calculate the maximum shear at point C due to series loads moving from right to left.

Kirakan daya ricih maksimum pada titik C yang disebabkan pergerakan beban siri dari arah kanan ke kiri.

[5 marks]

[5 markah]

- CLO3 (b) A beam in Figure A2(b) is subjected to a series of moving loads 15kN, 30kN, 20kN and 40kN respectively. The beam is a simply supported beam that is supported at point A and B. By using Influence Lines Diagram Method, evaluate the Absolute Maximum Moment due to a series loads.

Satu rasuk seperti Rajah A2(b) dikenakan satu beban siri yang terdiri daripada 15kN, 30kN, 20kN dan 40kN bergerak di atas rasuk. Rasuk ini adalah rasuk disokong mudah yang disokong pada titik A dan titik B. dengan menggunakan kaedah Gambarajah Garis Imbas, nilaikan Momen Maksimum Mutlak yang disebabkan oleh pergerakan satu siri beban tersebut.

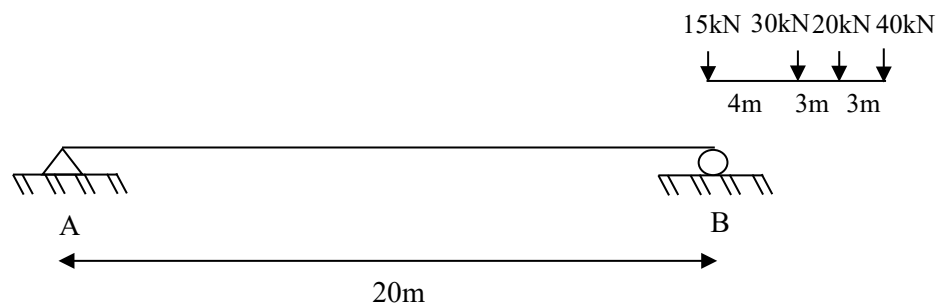

Figure A2(b)/Rajah A2(b)

[14 marks]

[14 markah]

SECTION B : 50 MARKS**BAHAGIAN B : 50 MARKAH****INSTRUCTION :**

This section consists of **FOUR (4)** subjective questions. Answer **TWO (2)** questions only.

ARAHAN :

Bahagian ini mengandungi EMPAT (4) soalan subjektif. Jawab DUA (2) soalan sahaja.

QUESTION 1**SOALAN 1**

- CLO1 (a) The statically indeterminate beam carries a point load and a uniformly distributed load as shown in Figure B1(a). By using the Slope Deflection Method, identify the Fixed End Moment values.

Satu rasuk tidak boleh tentu statik membawa beban tumpu dan beban teragih seragam seperti yang ditunjukkan dalam Rajah B1(a). Dengan menggunakan Kaedah Cerun Pesongan, kenal pasti nilai bagi Momen Hujung Terikat.

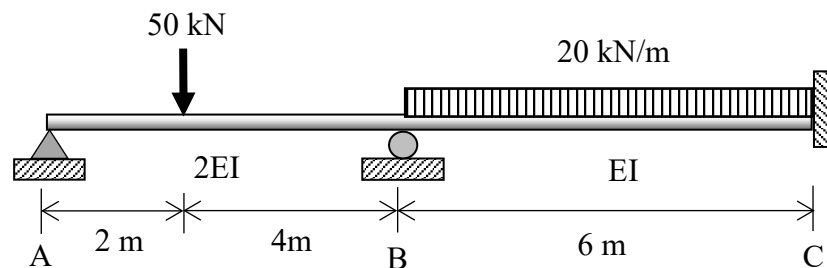

Figure B1(a) / Rajah B1(a)

[4 marks]

[4 markah]

- CLO1 (b) Show the Slope Deflection Equations for each member in Figure B1(a).
Tunjukkan Persamaan Cerun Pesongan bagi setiap anggota di dalam Rajah B1(a).

[6 marks]

[6 markah]

- CLO1 (c) A two-span continuous beam is subjected to load as shown in Figure B1(c). Given the value of Fixed End Moment as below:

*Satu rasuk selangar dua rentang dikenakan beban seperti dalam Rajah B1(c).
Diberi nilai Momen Hujung Terikat seperti di bawah:*

$$\text{FEM}_{AB} = -266.67 \text{ kNm}, \text{ FEM}_{BA} = +266.67 \text{ kNm},$$

$$\text{FEM}_{BC} = -26.67 \text{ kNm}, \text{ FEM}_{CB} = +26.67 \text{ kNm}$$

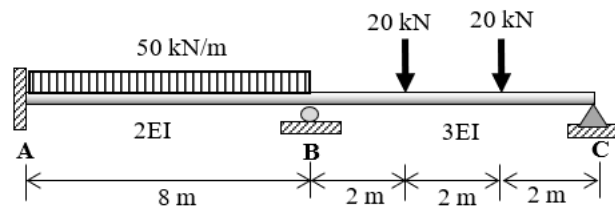

Figure B1(c) / Rajah B1 (c)

- i. Calculate the values of slope at support of the beam in Figure B1 (c).

Kirakan nilai kecerunan pada penyokong dalam rasuk di Rajah B1(c).

[7 marks]

[7 markah]

- ii. Calculate the value of final moment of the beam in Figure B1 (c).

Kirakan nilai momen akhir bagi rasuk di Rajah B1(c).

[8 marks]

[8 markah]

QUESTION 2

SOALAN 2

- CLO1 (a) A statically indeterminate portal frame is loaded as shown in Figure B2(a). Identify the value of Fixed End Moment for each member.
- Satu kerangka portal tidak boleh tentu statik dikenakan beban seperti dalam Rajah B2(a). Kenal pasti nilai Momen Hujung Terikat bagi setiap anggota.*

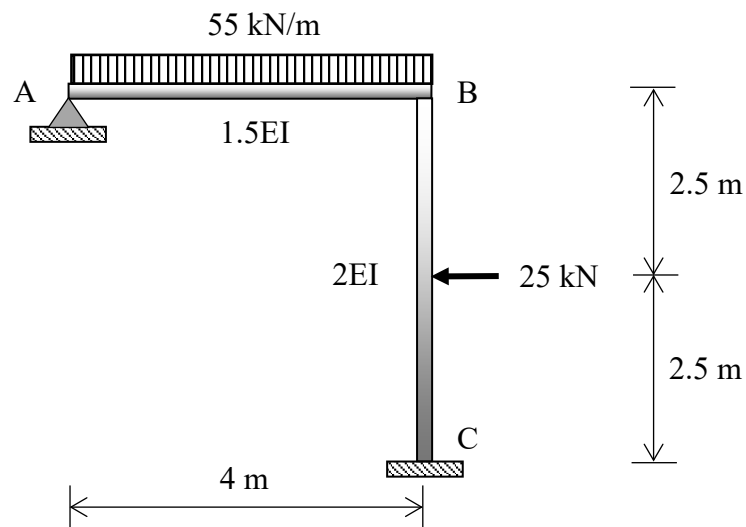

Figure B2(a) / Rajah B2(a)

[4 marks]

[4 markah]

- CLO1 (b) Identify the slope deflection equation for each member that experiences the internal moments in Figure B2(a).
- Kenal pasti persamaan cerun pesongan bagi setiap anggota yang mengalami momen dalaman di Rajah B2(a).*

[6 marks]

[6 markah]

- CLO1 (c) A non-sway portal frame is loaded as shown in Figure B2(c). The final moment at support is given as follows:

Sebuah kerangka portal tanpa huyung dikenakan beban seperti ditunjukkan dalam Rajah B2(c). Momen akhir pada penyokong diberikan seperti berikut:

$$M_{AB} = -11.974 \text{ kNm}$$

$$M_{BC} = -9.806 \text{ kNm}$$

$$M_{BA} = +9.802 \text{ kNm}$$

$$M_{CB} = +3.497 \text{ kNm}$$

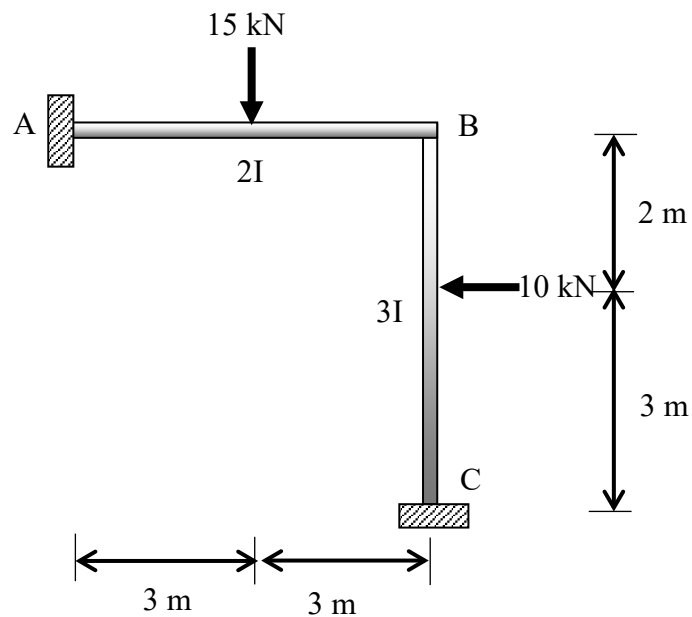

Figure B2(c) / Rajah B2(c)

- i. Calculate the reaction at the support of the portal frame in Figure B2(c).
Kirakan nilai tindakbalas pada penyokong kerangka portal dalam Rajah B2(c).

[7 marks]

[7 markah]

- ii. Sketch the Bending Moment Diagram (BMD) for Figure B2(c).
Lakarkan Gambarajah Momen Lentur (GML) bagi Rajah B2(c).

[8 marks]

[8 markah]

QUESTION 3**SOALAN 3**

A continuous beam as shown in Figure B3(a) is subjected to point load and uniformly distributed load. By using the Moment Distribution Method:

Sebuah rasuk selanjur seperti ditunjukkan dalam Rajah B3(a) dikenakan beban tumpu dan beban teragih seragam. Dengan menggunakan Kaedah Agihan Moment:

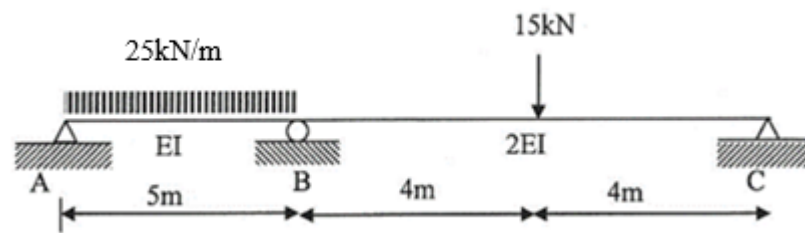

Figure B3(a)/Rajah B3(a)

- CLO1 (a) Identify the value of Fixed End Moment (FEM) for each member in Figure B3(a)
Kenal pasti nilai Momen Hujung Terikat (MHT) bagi setiap anggota dalam Rajah B3(a).

[4 marks]

[4 markah]

- CLO1 (b) Indicate the value of stiffness factor and distribution factor for each support in Figure B3(a).
Tunjukkan nilai faktor kekukuhan dan faktor agihan pada setiap penyokong dalam Rajah B3(a).

[6 marks]

[6 markah]

CLO1

- (c) A statically indeterminate beam is subjected to uniformly distributed load and point load as shown in Figure B3(c). The value of Fixed End Moments and Distribution Factor is given in Table B3(c).

Satu rasuk tidak boleh tentu statik dikenakan beban teragih seragam dan beban tumpu seperti dalam Rajah B3(c). Nilai Momen Hujung Terikat dan Faktor Agihan telah diberikan dalam Jadual B3(c).

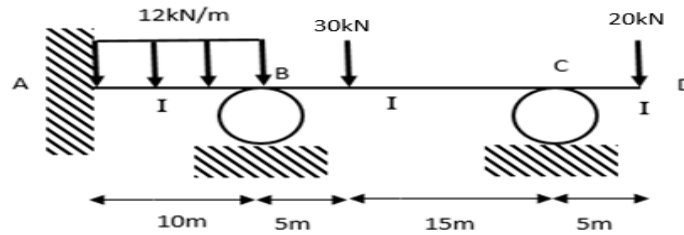

Figure B3(c)/Rajah B3(c)

Table B3(c)/Jadual B3(c)

| Fixed End Moments <i>Momen Hujung Terikat</i> | Distribution Factor <i>Faktor agihan</i> |
|--|---|
| $FEM_{AB} = -100\text{kNm}$ | $DF_{AB} = 0$ |
| $FEM_{BA} = 100\text{kNm}$ | $DF_{BA} = 0.67$ |
| $FEM_{BC} = -84.38\text{kNm}$ | $DF_{BC} = 0.33$ |
| $FEM_{CB} = 28.13\text{kNm}$ | $DF_{CB} = 1$ |
| $M_{CD} = -100\text{kNm}$ | $DF_{CD} = 0$ |

- i. Calculate the final moment for each span in Figure B3(c) by using Moment Distribution Method with **THREE (3)** times of distribution.

*Kirakan nilai momen akhir pada setiap rentang dalam Rajah B3(c) dengan menggunakan Kaedah Agihan Momen dengan **TIGA (3)** kali agihan.*

[7 marks]

[7 markah]

- ii. Identify the value of reaction at joint A, B and C in Figure B3(c).

Kenal pasti nilai daya tindakbalas di sambungan A, B dan C dalam Rajah B3(c).

[8 marks]

[8 markah]

QUESTION 4**SOALAN 4**

The structure shown Figure B4(a) is a non-swaying portal frame. EI is constant for each member.

Struktur yang ditunjukkan dalam Rajah B4(a) adalah sebuah kerangka tanpa huyung. EI adalah malar bagi setiap anggota.

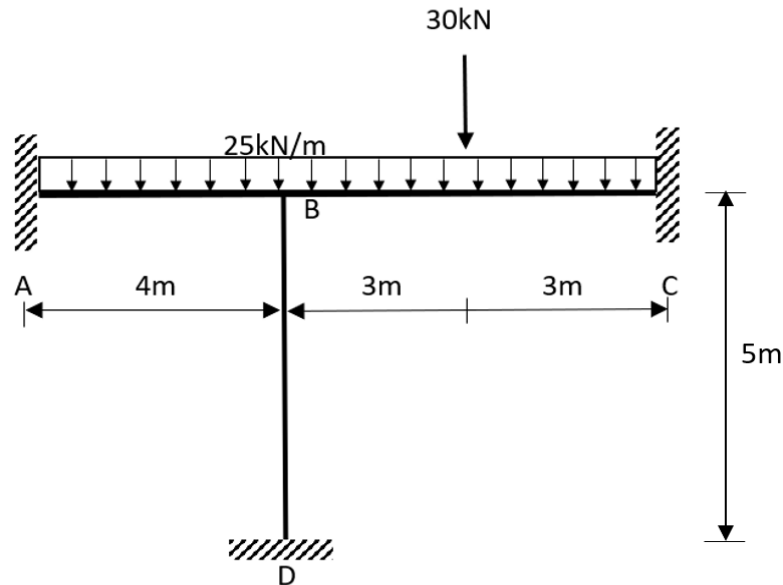

Figure B4(a)/ *Rajah B4(a)*

- CLO1 (a) Identify the value of fixed end moment (FEM) for all spans in Figure B4(a).
Kenal pasti nilai moment hujung terikat (MHT) untuk semua rentang dalam Rajah B4(a).
- [4 marks]
[4 markah]
- CLO1 (b) Identify the value of stiffness factors and distribution factors for each portal frame support in Figure B4(a).
Kenal pasti nilai faktor kekukuhan dan faktor agihan bagi setiap penyokong kerangka portal di Rajah B4(a).
- [6 marks]
[6 markah]

- CLO1 (c) A portal frame is loaded at the position as shown in Figure B4(c). Given value of FEM as in Table B4(c). By using Moment Distribution Method:

Sebuah kerangka portal dikenakan beban seperti dalam Rajah B4(c). Diberi nilai momen hujung terikat telah seperti dalam Jadual B4(c). Dengan menggunakan Kaedah Agihan Momen:

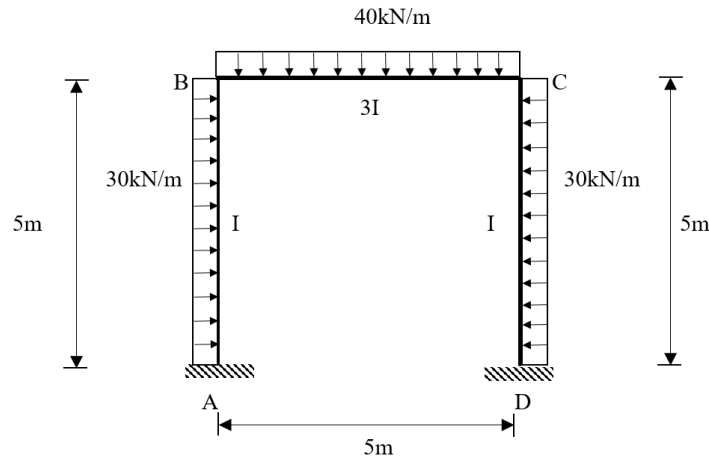

Figure B4(c)/ *Rajah B4(c)*

Table B4(c) / *Jadual B4(c)*

| | |
|-------------------------------|------------------------------|
| $FEM_{AB} = -62.5\text{kNm}$ | $FEM_{BA} = 62.5\text{kNm}$ |
| $FEM_{BC} = -83.33\text{kNm}$ | $FEM_{CB} = 83.33\text{kNm}$ |
| $FEM_{CD} = -62.5\text{kNm}$ | $FEM_{DC} = 62.5\text{kNm}$ |

- (i) Identify the stiffness factor and distribution factor for each support in Figure B4(c).

Tentukan faktor kekukuhan dan faktor agihan di setiap penyokong dalam Rajah B4(c).

[7 marks]

[7 markah]

- (ii) Calculate the final moment at joint A, B, C and D with **THREE (3)** times of distributions for Figure B4(c).

*Selesaikan momen akhir di sambungan A, B, C dan D dengan **TIGA (3)** kali agihan bagi Rajah B4(c).*

[8 marks]

[8 markah]

SOALAN TAMAT

| |
|---------------------------------------|
| DCC40163 – THEORY OF STRUCTURE |
|---------------------------------------|

| |
|----------------|
| FORMULA |
|----------------|

1. Slope Deflection Method

$$M_{AB} = \frac{2EI}{L} \left[2\theta_A + \theta_B - \frac{3\Delta}{L} \right] \pm M^F$$

$$M_{BA} = \frac{2EI}{L} \left[2\theta_B + \theta_A - \frac{3\Delta}{L} \right] \pm M^F$$

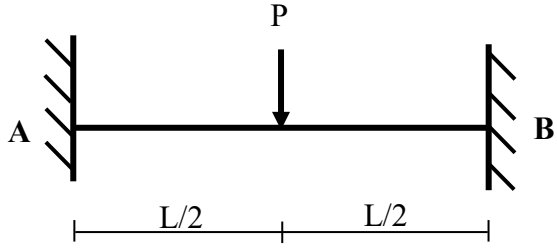
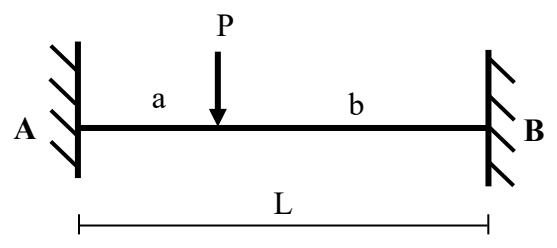
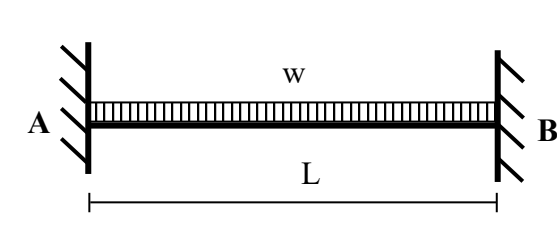
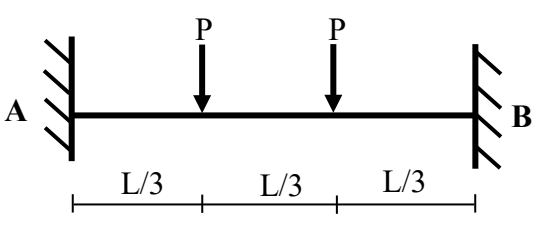
| | | |
|-------------------------|--|------------------------|
| $M_{AB}^F = -PL/8$ |  | $M_{BA}^F = PL/8$ |
| $M_{AB}^F = -Pab^2/L^2$ |  | $M_{BA}^F = Pba^2/L^2$ |
| $M_{AB}^F = -wL^2/12$ |  | $M_{BA}^F = wL^2/12$ |
| $M_{AB}^F = -2PL/9$ |  | $M_{BA}^F = 2PL/9$ |

2. Moment Distribution Method

- i. Stiffness Factor

$$K = 4EI / L \text{ (for Fixed or Continuous)}$$

$$K = 3EI / L \text{ (for Pinned or Roller)}$$

- ii. Distribution Factor

$$DF = K / \sum K$$

$$DF = 0 \text{ (for Fixed)}$$

$$DF = 1 \text{ (for Pinned or Roller)}$$

3. Statically Indeterminate Truss

- i. Redundant Force

$$R = - \frac{\sum P\mu L}{\sum \mu^2 L / AE}$$

- ii. Internal Force

$$F = P + \mu R$$

4. Displacement

- i. Displacement caused by the external load

$$\delta = \sum \left[\frac{P\mu L}{AE} \right]$$

5. Influence Lines

- i. $R_A = 1 - x/L$, $R_B = x/L$
- ii. $V_C = -x/L$, $V_C = 1 - x/L$
- iii. $M_C = bx/L$, $M_C = a(1 - x/L)$