

**SULIT**



**KEMENTERIAN PENDIDIKAN TINGGI  
JABATAN PENDIDIKAN POLITEKNIK DAN KOLEJ KOMUNITI**

**BAHAGIAN PEPERIKSAAN DAN PENILAIAN  
JABATAN PENDIDIKAN POLITEKNIK DAN KOLEJ KOMUNITI  
KEMENTERIAN PENDIDIKAN TINGGI**

**JABATAN KEJURUTERAAN AWAM**

**PEPERIKSAAN AKHIR**

**SESI I : 2025/2026**

**DCC30122 : FLUID MECHANICS**

**TARIKH : 28 NOVEMBER 2025**

**MASA : 8.30 PAGI – 10.30 PAGI (2 JAM)**

---

Kertas soalan ini mengandungi **TIGA BELAS (13)** halaman bercetak.

Bahagian A: Subjektif (2 soalan)

Bahagian B: Subjektif (4 soalan)

Dokumen sokongan yang disertakan : Formula

---

**JANGAN BUKA KERTAS SOALAN INI SEHINGGA DIARAHKAN**

(CLO yang tertera hanya sebagai rujukan)

**SULIT**

**SECTION A: 50 MARKS*****BAHAGIAN A: 50 MARKAH*****INSTRUCTION:**

This section consists of **TWO (2)** subjective questions. Answer **ALL** questions.

***ARAHAN:***

*Bahagian ini mengandungi DUA (2) soalan subjektif. Jawab SEMUA soalan.*

**QUESTION 1*****SOALAN 1***

- CLO1 (a) Describe Newtonian fluid and non-Newtonian fluid.  
*Huraikan bendalir Newtonian dan bendalir non-Newtonian.*
- [4 marks]  
[4 markah]
- CLO1 (b) A rectangular container is half-filled with 4500N oil. Estimate the value of specific volume if the container is 1.5m long, 0.65m wide and 1.0m in high.  
*Bekas berbentuk segiempat diisi separuh oleh 4500N minyak. Anggarkan nilai isipadu tentu sekiranya bekas tersebut berukuran 1.5m panjang, 0.65m lebar dan 1.0m tinggi.*
- [8 marks]  
[8 markah]

CLO1

- (c) At room temperature, the kinematic viscosity of 8400N crude oil is  $3.50 \times 10^{-5} \text{m}^2/\text{s}$ . Estimate the following fluid properties if the specific gravity of crude oil is  $\frac{2}{3}$  of water:

*Pada suhu bilik, kelikatan kinematik bagi 8400N minyak mentah adalah  $3.50 \times 10^{-5} \text{m}^2/\text{s}$ . Anggarkan sifat bendalir berikut sekiranya graviti tentu bagi minyak mentah adalah  $\frac{2}{3}$  daripada air:*

- i. Specific weight

*Berat tentu*

[6 marks]

[6 markah]

- ii. Volume of crude oil

*Isipadu minyak mentah*

[7 marks]

[7 markah]

**QUESTION 2****SOALAN 2**

- CLO1 (a) Describe **TWO (2)** pressure-measuring devices.  
*Huraikan **DUA (2)** alat yang digunakan untuk mengukur tekanan.*
- [4 marks]  
[4 markah]
- CLO1 (b) Identify the value of gauge pressure and absolute pressure at a point of 3.5 m below the free surface of a fluid with a density of  $2.55 \times 10^3 \text{ kg/m}^3$  if the atmospheric pressure is equivalent to 860 mm of mercury.  
*Kenal pasti nilai tekanan tolok dan tekanan mutlak pada aras 3.5m di bawah permukaan terbuka bagi bendalir yang mempunyai ketumpatan  $2.55 \times 10^3 \text{ kg/m}^3$  jika tekanan atmosfera bersamaan 860mm ketinggian merkuri.*
- [8 marks]  
[8 markah]
- CLO1 (c) Figure A2(c) shows a differential manometer which is connected to two pipes, Pipe A and Pipe B. Pipe A contains water while pipe B is carries oil of specific gravity of 0.83. The pressure at pipe A is  $107 \text{ kN/m}^2$  and pressure at pipe B is  $30.5 \text{ kN/m}^2$ .  
*Rajah A2(c) menunjukkan manometer pembezaan yang dihubungkan kepada 2 paip iaitu paip A dan B. Paip A mengandungi air manakala paip B mengalirkan minyak dengan graviti tentu 0.83. Tekanan pada paip A adalah  $107 \text{ kN/m}^2$  dan tekanan paip B adalah  $30.5 \text{ kN/m}^2$ .*

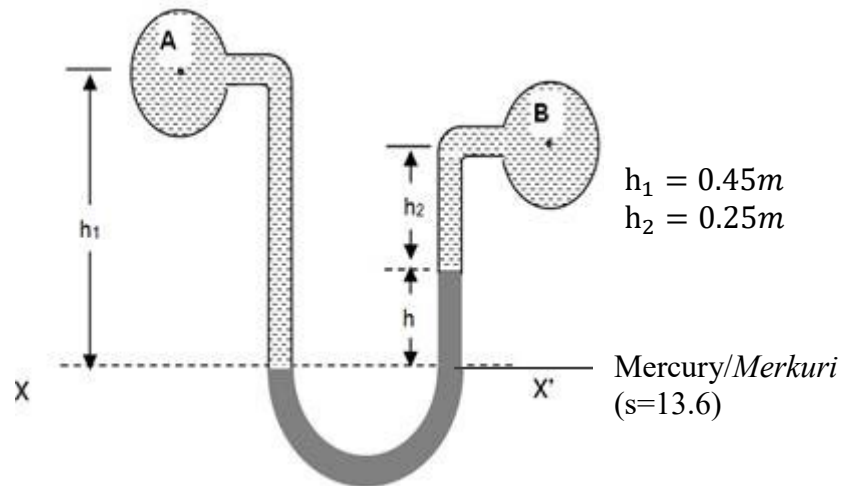

Figure A2(c) /Rajah A2(c)

- i. Express equation to calculate the height of the mercury ( $h$ ) flowing in the right limb.

*Terjemahkan persamaan untuk menghitung ketinggian merkuri ( $h$ ) yang mengalir pada tiub di sebelah kanan.*

[6 marks]

[6 markah]

- ii. Estimate the value of  $h$ .

*Anggarkan nilai  $h$ .*

[7 marks]

[7 markah]

**SECTION B: 50 MARKS****BAHAGIAN B: 50 MARKAH****INSTRUCTION:**

This section consists of **FOUR (4)** subjective questions. Answer **TWO (2)** questions.

**ARAHAN:**

*Bahagian ini mengandungi EMPAT (4) soalan subjektif. Jawab DUA (2) soalan sahaja.*

**QUESTION 1****SOALAN 1**

- CLO 2 (a) The provided visualization shows the fundamental differences between two distinct types of fluid flow. It illustrates how fluid particles behave within a pipe under these two conditions. By referring to Figure B1(a), relate the type of fluids flowing in pipe A and B and its behaviours.

*Visualisasi yang diberikan menunjukkan perbezaan asas antara dua jenis aliran bendalir yang berbeza. Ia menggambarkan bagaimana zarah-zarah bendalir berkelakuan di dalam paip di bawah dua keadaan ini. Merujuk kepada Rajah B1(a), kaitkan jenis bendalir yang mengalir di dalam paip A dan B dengan sifat-sifatnya.*

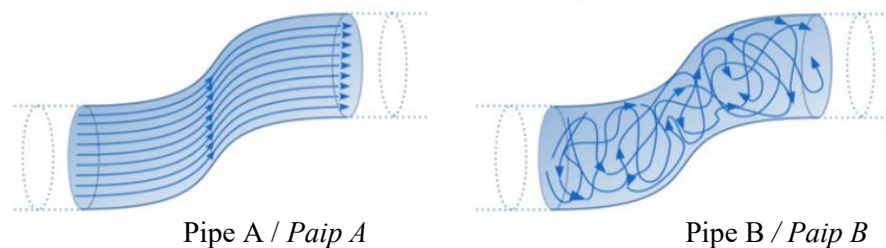

Figure B1(a) / Rajah B1(a)

[4 marks]

[4 markah]

- CLO2 (b) An oil of dynamic viscosity of  $0.6 \text{ Ns/m}^2$  has a density of  $800 \text{ kg/m}^3$  and discharges at a rate of  $2.5 \times 10^{-2} \text{ m}^3/\text{s}$  flowing horizontally through a pipe with a diameter of 250 mm. Calculate Reynolds number for the flow.
- Minyak dengan kelikatan dinamik  $0.6 \text{ Ns/m}^2$  mempunyai ketumpatan  $800 \text{ kg/m}^3$  dan kadar alir  $2.5 \times 10^{-2} \text{ m}^3/\text{s}$  mengalir menerusi paip secara melintang dengan diameter 250 mm. Kirakan nombor Reynolds bagi aliran tersebut.*
- [9 marks]  
[9 markah]
- CLO2 (c) A pipe with a diameter of 850 mm carries a fluid of specific gravity of 0.92. The discharge from the pipe is at 950 L/s and given dynamics viscosity of the fluid is  $1.50 \times 10^{-2} \text{ Ns/m}^2$ . Classify the type of flow for the fluid.
- Paip berdiameter 850 mm mengalirkan bendalir dengan graviti tentu 0.92. Kadar alir daripada paip adalah 950 L/s dan nilai kelikatan dinamik yang diberi adalah  $1.50 \times 10^{-2} \text{ Ns/m}^2$ . Kelaskan jenis aliran bendalir tersebut.*
- [12 marks]  
[12 markah]

**QUESTION 2****SOALAN 2**

- CLO2 (a) Water flows through a horizontal pipe at one point. According to the continuity equation, as the pipe gets narrower, the water must flow faster to maintain the same flow rate. With the aid of a diagram, explain the continuity equation.
- Air mengalir melalui satu paip melintang pada satu titik. Berdasarkan persamaan keterusan, apabila paip semakin mneyempit, air mesti mengalir dengan lebih cepat untuk mengekalkan kadar aliran yang sama. Dengan bantuan gambarajah, terangkan persamaan keterusan.*

[4 marks]

[4 markah]

- CLO2 (b) Water is flowing through pipe A with a diameter of 25 cm to pipe B with a diameter of 90 cm. Then, it is branches into two pipes which is pipe C with a diameter of 5 cm and pipe D, 9 cm . If the velocity at A is 1.8 m/s and 3 m/s at D, calculate the discharge at C and D, as well as the velocity at B and C.
- Air mengalir melalui paip A yang berdiameter 25 cm ke paip B yang berdiameter 90 cm. Kemudian ia bercabang kepada dua bahagian paip iaitu paip C dengan diameter 5 cm dan paip D dengan diameter 9 cm. Jika halaju di A adalah 1.8 m/s dan 3 m/s di D, kirakan kadaralir di C dan D juga halaju di B dan C.*

[9 marks]

[9 markah]

CLO2

- (c) A pipe with 8 m long is slanted downward at an angle of  $20^\circ$  horizontally. The diameter of the pipe changed from 350 mm at section 1 to 250 mm at section 2 and the pressure of water at section 1 is 500 kPa as shown in Figure B2(c). If the velocity of flow at section 1 is 1.5 m/s, calculate the intensity of pressure at section 2.

*Sebuah paip dengan 8 m panjang dicondongkan ke bawah sebanyak  $20^\circ$  secara mengufuk. Diameter paip adalah berubah daripada 350 mm di bahagian 1 kepada 250 mm di bahagian 2 dan tekanan air di bahagian 1 adalah 500 kPa seperti ditunjukkan dalam Rajah B2(c). Jika halaju yang mengalir di bahagian 1 ialah 1.5 m/s, kirakan tekanan di bahagian 2.*

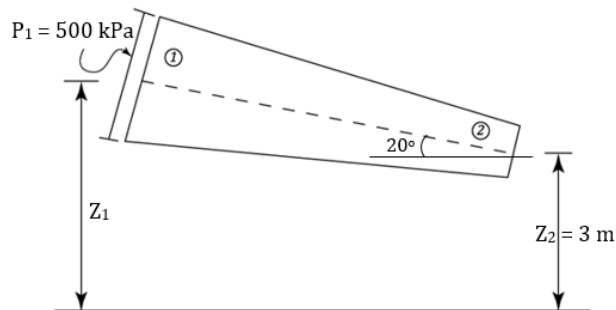

Datum Line / *Garis Datum*

Figure B2(c) / *Rajah B2(c)*

[12 marks]

[12 markah]

**QUESTION 3****SOALAN 3**

- CLO2 (a) Water flows steadily through a horizontal pipe. The pipe has a sudden bend (an elbow), which causes a minor loss due to changes in flow direction and turbulence. Explain **TWO (2)** characteristics of that fluid flow with the aid of a diagram and formula.

*Air mengalir dengan seragam melalui paip melintang. Paip tersebut mempunyai bengkokan mengejut, yang menyebabkan kehilangan kecil disebabkan oleh perubahan pada arah aliran dan gelora. Terangkan **DUA (2)** ciri bagi aliran bendalir tersebut dengan bantuan gambarajah dan rumus.*

[4 marks]

[4 markah]

- CLO2 (b) Two reservoirs with 9 m of water level difference were connected by a pipe system. The pipe connection at the first 0.3 km has a diameter of 200 mm and the last 0.4 km of pipe has a diameter of 400 mm. Considering all minor losses, calculate the discharge through the pipe system if the friction factor ( $f$ ) is 0.01 for both sections of the pipe.

*Dua tangki takungan dengan perbezaan ketinggian 9 m telah disambungkan dengan sistem paip. Sambungan paip pada 0.3 km pertama mempunyai diameter paip bersaiz 200mm dan paip pada 0.4 km terakhir mempunyai diameter bersaiz 400 mm. Dengan mengambil kira semua kehilangan tenaga, kirakan kadar alir yang mengalir dalam system paip jika faktor geseran ( $f$ ) adalah 0.01 untuk kedua-dua bahagian paip.*

[9 marks]

[9 markah]

- CLO2 (c) Water is flowing from tank A to tank B through two parallel pipes as shown in Figure B3(c). The length and diameter of the pipes are given in Table B3(c). Calculate the total flow rate in a pipe system if the friction factor ( $f$ ) is 0.008 for both pipes. Consider all head losses.

*Air mengalir dari tangki A ke tangki B melalui dua paip selari seperti yang ditunjukkan dalam Rajah B3(c). Panjang dan diameter kedua-dua paip adalah seperti yang ditunjukkan dalam Jadual B3(c). Kirakan jumlah kadar alir dalam sistem paip jika faktor geseran ( $f$ ) adalah 0.008 untuk kedua-dua batang paip. Ambil kira semua kehilangan tenaga.*

Table B3(c) / Jadual B3(c)

Pipe/Paip	Diameter / Diameter(mm)	Length/Panjang (m)
1	50	140
2	100	140

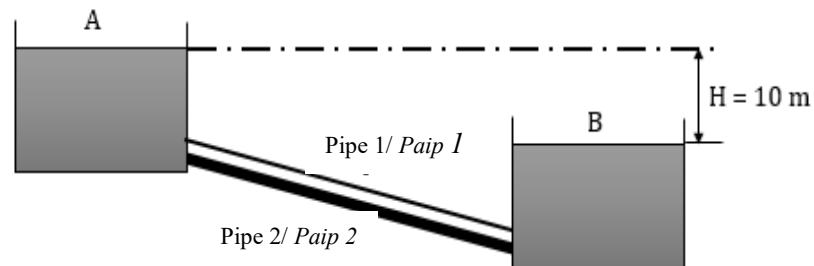

Figure B3 (c) / Rajah B3 (c)

[12 marks]

[12 markah]

**QUESTION 4****SOALAN 4**

- CLO2 (a) A jet ski moves forward by forcefully pushing water out through its jet nozzle at the back. The jet ski's engine pushes water backward at high speed. According to Newton's Third Law, the water pushes the jet ski forward with an equal and opposite force. Explain Newton's Third Law with the aid of a diagram.
- Sebuah jet ski bergerak ke hadapan dengan menolak air secara paksa melalui corong di belakang jet. Enjin jet ski menolak air ke belakang pada kelajuan yang tinggi. Menurut Hukum Newton Ketiga, air menolak jet ski ke hadapan dengan daya bertentangan yang setara. Terangkan Hukum Newton Ketiga dengan bantuan gambarajah.*
- [4 marks]  
[4 markah]
- CLO2 (b) A jet of oil, with specific gravity of 0.8 has a diameter of 75 mm, strikes normally a stationary flat plate. If the force exerted by the jet on the plate is 1400N, determine the flow rate of the oil.
- Pancutan minyak dengan graviti tentu 0.8 mempunyai diameter 75 mm mengenai secara normal satu plat rata pegun. Jika daya yang dikenakan oleh jet minyak ke atas plat adalah 1400N, tentukan kadar alir minyak tersebut.*
- [9 marks]  
[9 markah]
- CLO2 (c) A jet of water with a diameter of 60 mm enters a fixed curved vane with a velocity of 25 m/s at an angle of  $40^\circ$ . The jet leaves the vane at an angle of  $30^\circ$  as shown in Figure B4(c). Assuming there is no loss of energy due to impact and friction, calculate the magnitude and direction of the resultant force.
- Pancutan air dengan diameter 60 mm menghentam lengkungan pegun dengan halaju 25 m/s pada sudut  $40^\circ$ . Pancutan air tersasar dari lengkungan pada  $30^\circ$  seperti yang ditunjukkan dalam Rajah B4(c). Dengan menganggap tiada kehilangan tenaga disebabkan impak dan geseran, kirakan daya dan arah tindakan daya.*

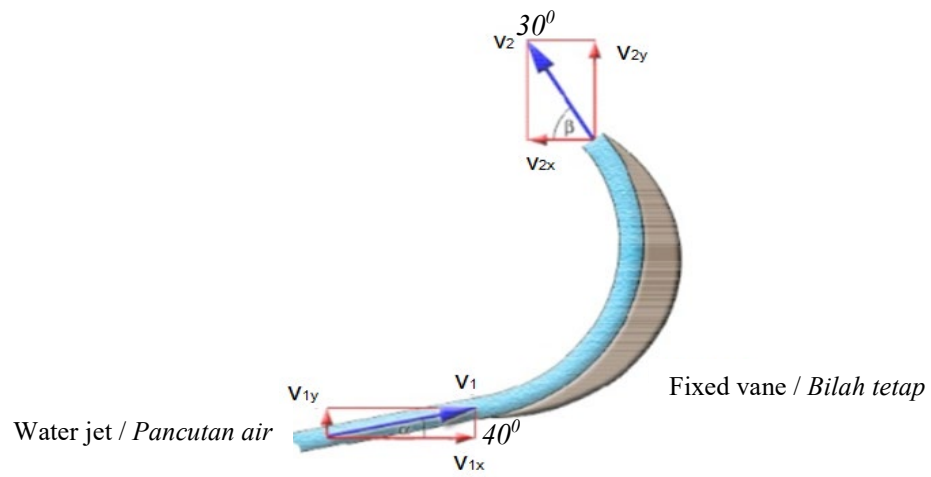

Figure B4(c) / Rajah B4(c)

[12 marks]

[12 markah]

**SOALAN TAMAT**

**LIST OF FORMULAS  
DCC30122 FLUID MECHANICS**

Fluid Characteristics	
$\rho = \frac{m}{V}$ $s = \frac{\rho_{liquid}}{\rho_{water}}$ $\omega = \frac{W}{V}$	$W = m g$ $V_s = \frac{1}{\rho}$ $\vartheta = \frac{\mu}{\rho}$
Measurement of Pressure	
$P = \rho g h$ $P_{abs} = P_{atm} + P_g$	
Hydrodynamics	
$R_e = \frac{\rho v d}{\mu} = \frac{v d}{\vartheta}$	
Flow Measurement and Bernoulli's Equation	
$Q = A v$ $H = \frac{P}{\rho g} + \frac{v^2}{2g} + z$ $\frac{P_1}{\rho g} + \frac{v_1^2}{2g} + z_1 = \frac{P_2}{\rho g} + \frac{v_2^2}{2g} + z_2$ $H = \left( \frac{s_h}{s_o} - 1 \right) \times h$ $H = \left( 1 - \frac{s_h}{s_o} \right) \times h$ $Q_{act} = C_d \times \left[ \frac{A_1 \times A_2}{\sqrt{(A_1)^2 - (A_2)^2}} \right] \times \sqrt{2gh}$ $Q = \frac{2}{3} C_d b \sqrt{2g} \times \left[ (H_2)^{\frac{3}{2}} - (H_1)^{\frac{3}{2}} \right]$	$C_c = \frac{A_j}{A_0}$ $C_v = \frac{v_{actual}}{v_{theory}}$ $C_d = C_v \times C_c$ $v_{the} = \sqrt{2 g H}$ $v_{act} = C_v \sqrt{2 g H}$ $Q_{the} = A_o \sqrt{2 g H}$ $Q_{act} = C_d A_o \sqrt{2 g H}$

## Fluid Flow

$$h_L = \frac{(v_1 - v_2)^2}{2g}$$

$$h_L = \left[ \frac{1}{C_c} - 1 \right] \frac{(v_2)^2}{2g}$$

$$h_L = \frac{0.5 (v_1)^2}{2g}$$

$$h_L = \frac{(v_2)^2}{2g}$$

$$h_L = \frac{k v^2}{2g}$$

$$h_f = \frac{4 f L v^2}{2gd} = \frac{f L Q^2}{3d^5}$$

$$h_f = \frac{32 \mu v L}{\rho g d^2}$$

$$\frac{P_1 - P_2}{\rho g} = h_f = \frac{32 \mu v L}{\rho g d^2}$$

$$\frac{P_1}{\rho g} + \frac{v_1^2}{2g} + z_1 = \frac{P_2}{\rho g} + \frac{v_2^2}{2g} + z_2 + \Sigma_{loss}$$

$$\frac{4 f_1 L_1 (v_1)^2}{2gd_1} = \frac{4 f_2 L_2 (v_2)^2}{2gd_2}$$

## Momentum Equation

$$F_x = \rho A v^2$$

$$F_x = \rho A (v - u)^2$$

$$F_n = \rho A v^2 \sin \theta$$

$$F_n = \rho A (v - u)^2 \sin \theta$$

$$F_x = F_n \sin \theta$$

$$F_y = F_n \cos \theta$$

$$F_x = \rho A v [ v_{1x} \cos \alpha + v_{2x} \cos \beta ]$$

$$F_y = \rho A v [ v_{1y} \sin \alpha - v_{2y} \sin \beta ]$$

$$F_x = \rho A (v - u) [(v_{1x} - u) \cos \alpha + (v_{2x} - u) \cos \beta]$$

$$F_y = \rho A (v - u) [(v_{1y} - u) \sin \alpha - (v_{2y} - u) \sin \beta]$$

$$F_x = \rho Q [ v_{1x} - v_{2x} \cos \theta ] + P_{1x} A_{1x} - P_{2x} A_{2x} \cos \theta ]$$

$$F_y = -\rho Q ( v_{2y} \sin \theta ) - P_{2y} A_{2y} \sin \theta$$

$$F_R = \sqrt{F_x^2 + F_y^2}$$

$$\alpha = \tan^{-1} \left( \frac{F_y}{F_x} \right)$$