



# **COOLING SYSTEM, COOLING TOWER AND CHILLER**

ZULKURNAIN HASSAN | RAZIMAH ABDUL RAHIM

# **COOLING SYSTEM, COOLING TOWER AND CHILLER**

**Edisi Pertama**

**Perpustakaan Nrgara Malayis, SEPTEMBER 2023**

**Hakcipta terpelihara. Tiada bahagian ini boleh diterbitkan semula atau ditukat dalam apa jua bentuk dengan cara apa jua sama ada secara elektronik, mekanikal, fotokopi, rakaman dan sebagainya sebelum mendapat kebenaran dari Ketua Pengarah Perpustakaan Negara Malaysia.**

**EDITOR**

**Nur Hidayah Moktar**

**WRITERS**

**Zulkurnain Hassan**

**Razimah Abdul Rahim**

**Published by:**

**POLITEKNIK PORT DICKSON**

**Km 14, JALAN PANTAI, SI RUSA**

**71050 PORT DICKSON**

**NEGERI SEMBILAN**

**TEL : 06-6622023 (Pustakawan)**

**06-6622048 (Kauunter)**



Cataloguing-in-Publication Data

Perpustakaan Negara Malaysia

A catalogue record for this book is available  
from the National Library of Malaysia

eISBN 978-967-2897-99-6

# PRAKATA

Alhamdulillah, atas segala curahan hidayah dan maunah-Nya, penulis dapat menyelesaikan buku ini. Syukur yang tak terkira. Setelah bergelut dengan waktu, akhirnya penulis dapat menyusun tulisan-tulisan yang telah berserak dimana-mana. Ada yang ditulis ulang, ada pula yang hanya cukup menatanya. Hingga akhirnya buku karya yang jauh dari kata sempurna ini berhasil penulis hadirkan kepada pembaca

Buku *Cooling System, Cooling Tower and Chiller* ini ditulis untuk membantu pelajar Politeknik Malaysia untuk memperoleh pemahaman yang lebih baik tentang sistem penyejukan asas, menara dingin dan sistem penyejukan *chiller*. Buku ini juga dapat membantu pensyarah untuk menjalankan proses pengajaran dan pembelajaran kursus *Energy Efficiency Engenering* dengan lebih terancang dan tersusun

Pada akhir topik soalan-soalan tutorial juga disertakan bagi menguji dan menilai pemahaman pelajar. Disertakan juga glosori untuk memudahkan rujukan pengguna.

Akhir kata, semua kelemahan dan kekurangan dalam buku ini murni kedangkalan ilmu penulis. Untuk itu penulis mohon maaf sebesar-besarnya. Dan sudilah kiranya pembaca tercinta memberikan saran dan kritik demi perbaikan. Semoga menjadi pelecut semangat bagi penulis untuk senantiasa belajar dan terus belajar. Paling akhir, semoga karya sederhana ini dapat sedikit memberikan manfaat, baik kepada penulis dan juga pembaca umumnya.

Aamiin.

**ZULKURNAIN HASSAN | RAZIMAH RAHIM**

# CONTENTS

No	Content	Page
01	Cooling System	
	1.0 Fundamentals Of Cooling System	1
	1.1 Basic Cooling Cycle	3
02	Chiller	
	2.0 Introduction To Chiller System	4
	2.1 Chiller Component & Configuration	5
	2.2 Types Of Chillers	10
	2.3 Chiller System Configuration	15
	2.4 Chillers Selection Criteria	18
	2.5 Achieving And Maintaining Chiller Efficiency	21
	2.6 Efficient Electric Chiller	23
	2.7 Achieving And Maintaining Chiller Efficiency	24
03	Cooling Tower	
	3.0 Introduction To Cooling Tower	25
	3.1 Cooling Tower And Chiller	26
	3.2 Cooling Tower And Chiller Operation	27
	3.3 Type Of Cooling Tower	28
	3.4 Cooling Tower Part And Function	29
	3.5 Cooling Tower Parts And Operation	30
	3.6 Industrial Cooling Tower	31
	3.7 Factors Affecting Cooling Tower	35
	3.8 Cooling Tower Selection	35
	3.9 Cooling Tower Energy Efficiency	37
	3.10 Maintaining Cooling Tower Efficiency	38
04	Questions And Tutorial	39
05	Glossary	45

01

COOLING  
SYSTEM

# 1.0 FUNDAMENTALS OF COOLING SYSTEM



## REFRIGERATION

- A process of transferring heat from a low temperature region to a high temperature region
- It is a process of cooling a substance



## AIR-CONDITIONING

- the process of controlling and maintaining the properties of air like temperature, humidity, purity, direction of flow etc.



## AIR-CONDITION(A/C)

A/C are really needed everywhere. For smaller places like a house, it can be provided by A/C units



## CENTRALISED A/C

Once the place reaches a certain size, it becomes cost-effective to use a centralised system.



## GIANT A/C

Centralised systems use "chillers" which are basically giant A/C units but they work slightly differently because of their size.

Air conditioning systems are divided into 2 categories:

### 1. Indirect Expansion System / Secondary Coolant System

- Using other mediums (water, calcium chloride brine & glycol) for cold air delivery through the concept of heat transfer.
- Used on systems with large capacity and large areas.
- Widely used as a commercial / industrial unit.
- For example, a chiller unit.

### 2. Direct Expansion System

- Using a material medium for cold air delivery through the concept of heat transfer.
- Used on systems with a small capacity and a smaller area.
- Widely used as domestic & medium commercial units.
- For example, split units, VRV and so on.

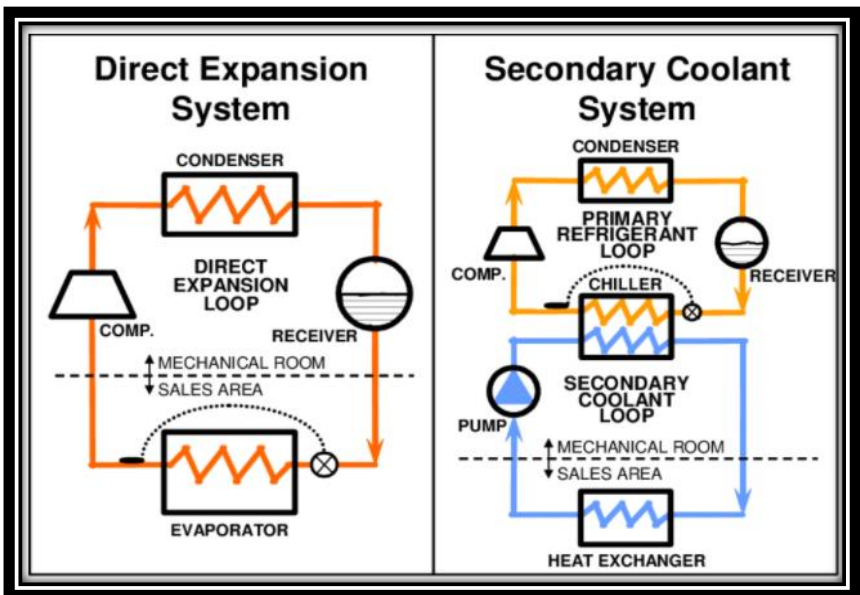

# 1.1 BASIC COOLING CYCLE

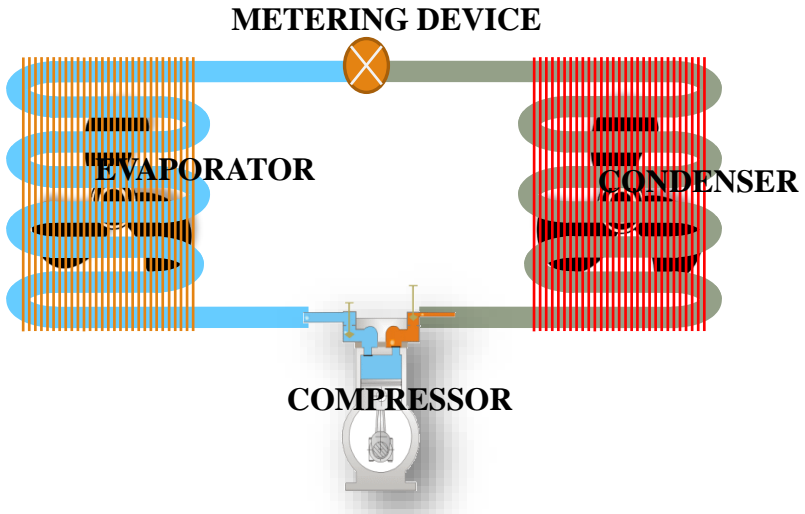

## METERING DEVICE

Functions to lower the pressure and temperature of the refrigerant liquid by controlling the rate of refrigerant liquid inflow to the evaporator.

## EVAPORATOR

Functions to absorb heat from the cooled space/room and convert the liquid form of the refrigerant into a low-temperature, low-pressure refrigerant gas.

## COMPRESSOR

Functioning to maintain the pressure difference between the high pressure and low pressure parts of the system.

## CONDENSER

It works to remove the heat absorbed from the evaporator and convert the gas form of the refrigerant into a high temperature and high pressure liquid refrigerant.

# 02 CHILLER

## 2.0 INTRODUCTION TO CHILLER SYSTEM

Chillers are a part of centralized air conditioning systems and form the single highest electricity consumer in building systems. Therefore, it is worthwhile to conduct a thorough analysis of chiller selection to realize the full potential and opportunity for energy savings. The longer the operating hours per year, the greater will be the opportunity to attain energy efficiency and savings through proper analysis and selection of chillers



### FUNCTION

A **chiller system** is an air conditioning system which **cools indoor air** and creates a more productive and comfortable **environment**.

### HOW

Chillers **generate chilled water**. It is used to provide air conditioning in buildings.

### WHY

All building generate a lot of **unwanted heat** (from the sun or from the equipment). This heat **needs to be removed** to keep the people inside at a **comfortable** temperature but also to make sure electrical and mechanical **equipment** is kept within certain thermal limits otherwise these will **break**.

### COMPRESSOR

### EXPANSION VALVE

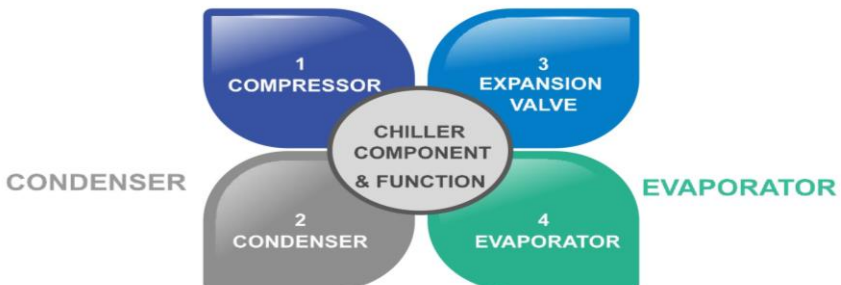

## 2.1 CHILLER COMPONENT & CONFIGURATION

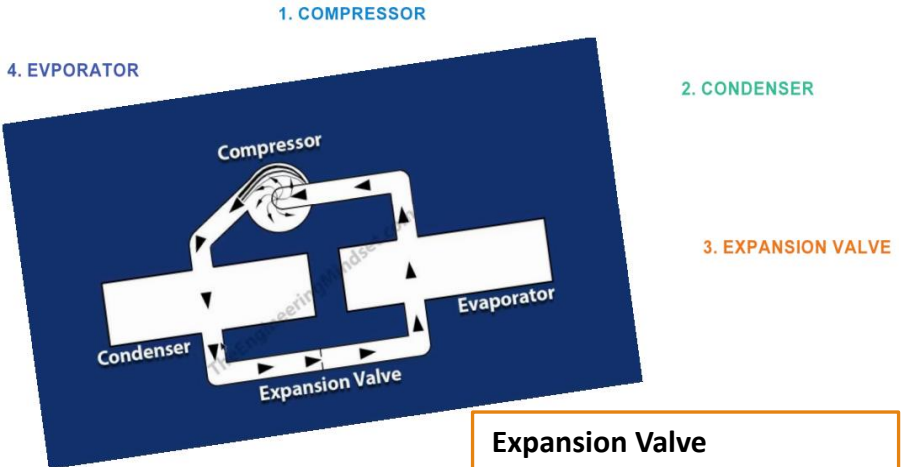

### Compressor

- The prime mover.
- It creates a pressure difference to move the refrigerant around the system.

### Expansion Valve

- Located after the compressor and before the expansion valve.
- The purpose of the condenser is to remove heat from the refrigerant which was picked up in the evaporator

### Condenser

- Located between the condenser and the evaporator.
- It's purpose is to expand the refrigerant reducing its pressure and increase it's volume which will allow it to pick up the unwanted heat in the evaporator

### Evaporator

- Located between the expansion valve and the compressor.
- Its purpose is to collect the unwanted heat from the building and move this into the refrigerant so that it can be sent to the cooling tower and rejected

## 2.1 CHILLER COMPONENT - COMPRESSOR

Most common type of compressors are:

- centrifugal
- screw
- scroll
- reciprocating



*Centrifugal type compressor*



*Reciprocating type compressor*



*Screw type compressor*



*Scroll type compressor*

## 2.1 CHILLER COMPONENT - COMPRESSOR

Two main types of condensers:

- Air cooled
- Water cooled



*Air cooled chiller*



*Water cooled chiller*

## 2.1 CHILLER COMPONENT - EXPANSION VALVA

Types of expansion valve:

- thermal expansion valve
- pilot operated thermal expansion valve
- electronic expansion valve

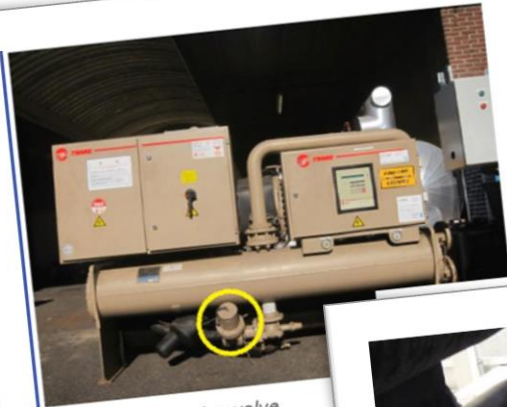

Electronic expansion valve



Thermal expansion valve



Pilot operated thermal expansion valve

## 2.1 CHILLER COMPONENT - EVAPORATOR

The types are based on:

- Air cooled evaporator
- Water cooled evaporator



*Evaporator on a water cooled chiller*



*Evaporator on an air cooled chiller*

## 2.2 TYPES OF CHILLERS

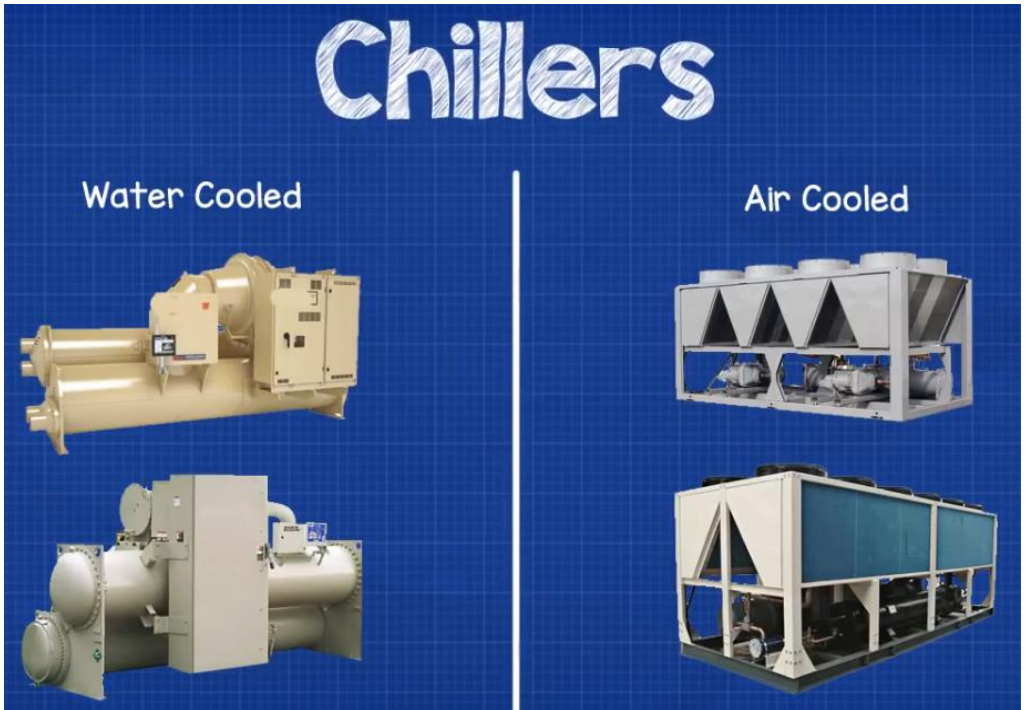

- Both types of chillers have the same essential components; the evaporator, the compressor, the condenser and the expansion valve.
- Air cooled or water cooled this simply refers to the way in which the unwanted heat is ejected from the building via the chiller's condenser

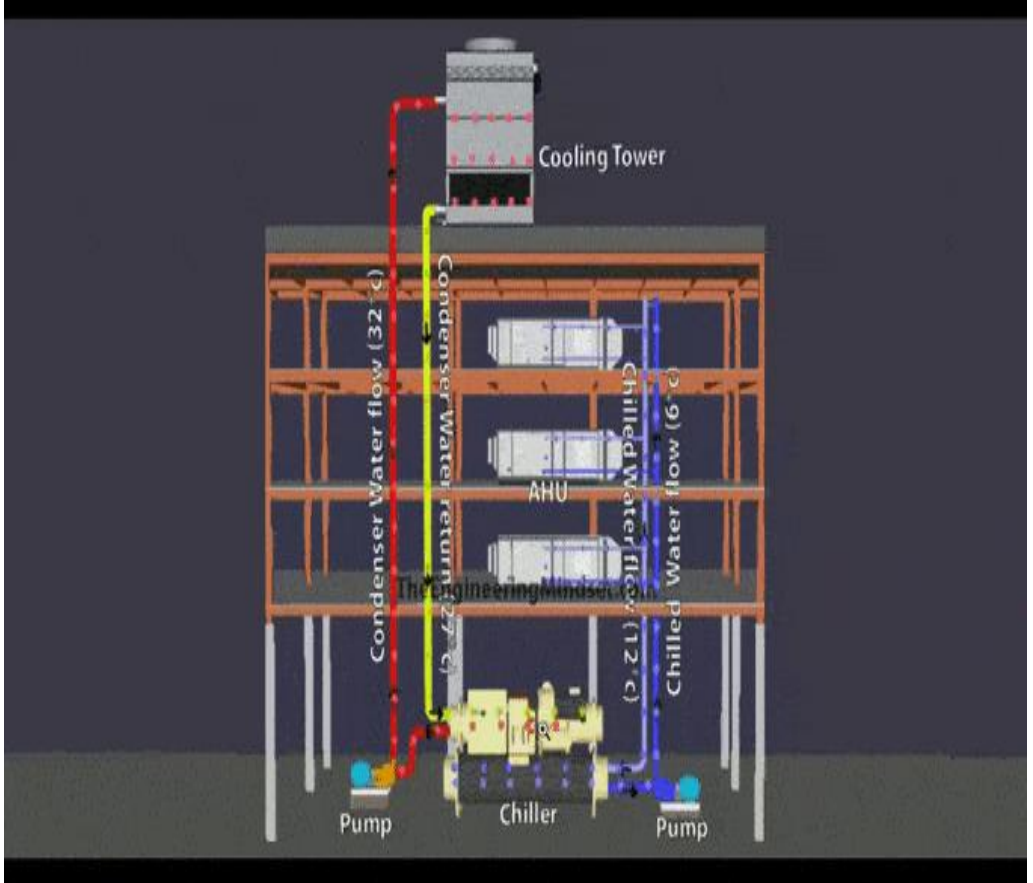

## Water Cooled Chiller

**Water cooled** chillers use cooling towers to discard the unwanted heat into atmosphere which was picked up in the building

**Water-cooled** systems are generally **more energy efficient** and have **more options** for features such as heat recovery.

Water cooled chillers have a sealed condenser and water is pumped through to take the heat away and disperse this through the cooling tower.

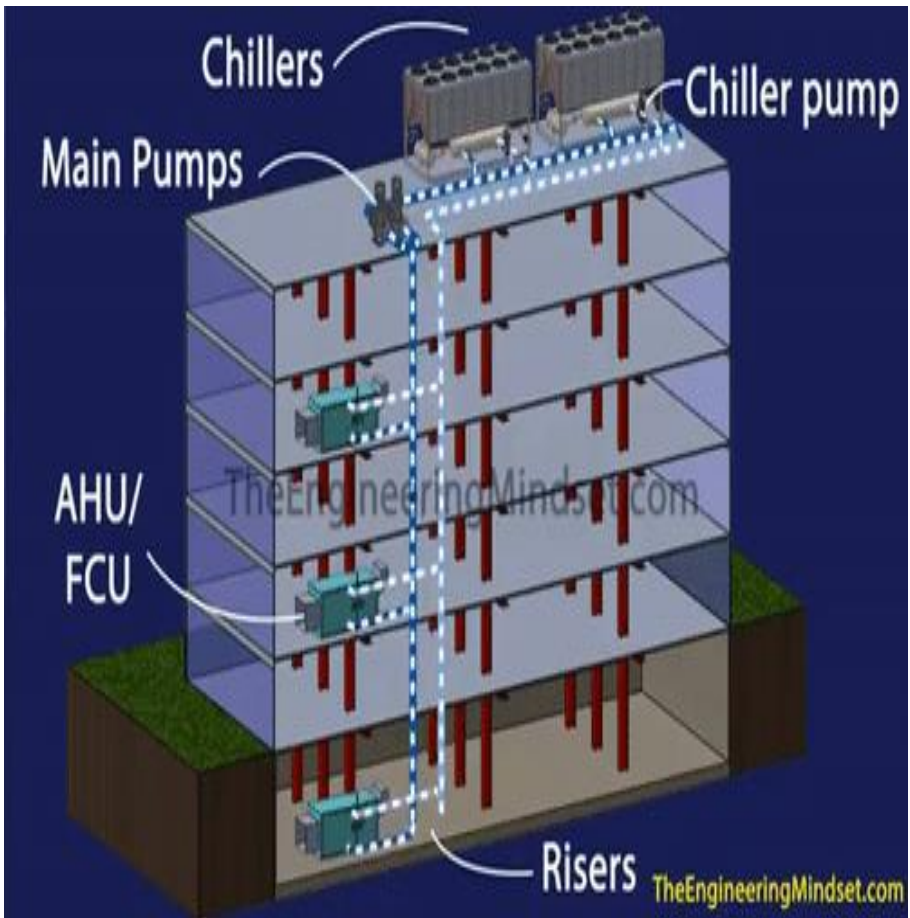

## Air Cooled Chiller

**Air cooled** chillers will blow air across their condenser to disperse the unwanted heat into the atmosphere.

Many **small chilled-water systems** use **air-cooled** chillers because of the **lower maintenance** requirements of the condensing circuit.

An air cooled chiller fans force air across the exposed tubes of the condenser which carry the heat away..

Chiller plants range in size from small capacity reciprocating compressor units (typically 100 – 750 kW<sub>r</sub>) with air or water-cooled condensers to medium/large screw compressors (typically 500 – 2,500 kW<sub>r</sub>) and large centrifugal compressors (above 1,000 kW<sub>r</sub>). Large chillers are normally water-cooled using re-circulated water from a cooling tower. Central chiller units are normally used in air conditioning system comprising air handling units each fitted with chilled water coils. Chillers are also commonly used for industrial processes or for mixed application (comfort air conditioning and process cooling).

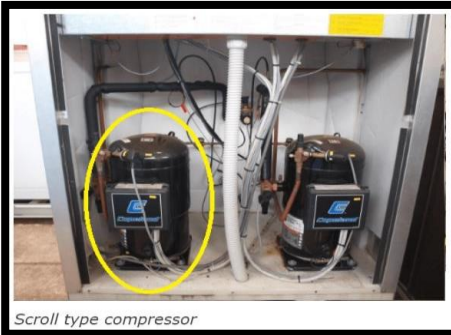

*Scroll type compressor*

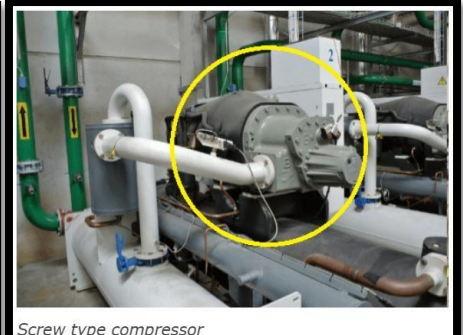

*Screw type compressor*



*Centrifugal type compressor*



*Reciprocating type compressor*

# Chiller Types & Application

## Explained

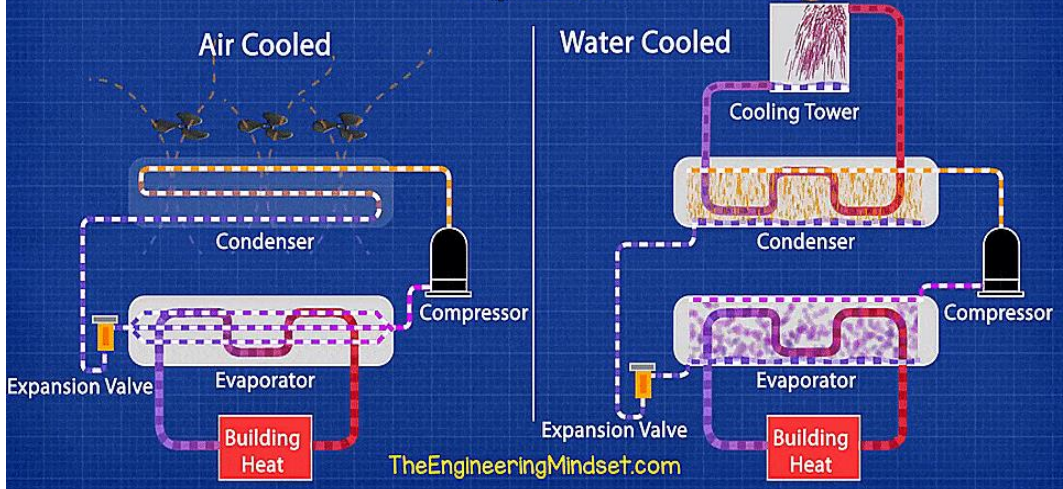

- The refrigeration cycle starts with a low-pressure liquid/gas mix entering the evaporator.

- Chillers use a refrigerant to move the unwanted heat between the evaporator and the condenser.

- In the **evaporator**, heat from the process water or water/glycol solution boils the refrigerant (changes from a low-pressure liquid to a low-pressure gas).

- The chilled water generated in evaporator is sent around the **building** by a pump to collect the unwanted heat and bring it back to the evaporator to be cooled down.

- The low-pressure refrigerant gas enters the **compressor** where it is compressed to high-pressure refrigerant gas.

- The condenser puts this unwanted heat into another loop which is sent by a pump to the cooling towers to send it into **atmosphere** or it will send it to a **cooling coil** where a fan blows the heat away.

- The high-pressure gas enters the **condenser** where ambient air or condenser water removes heat to cool it to a high-pressure liquid.

- The high-pressure liquid travels to the **expansion valve**, which controls how much liquid refrigerant enters the evaporator, thereby beginning the refrigeration cycle again.

## 2.3 CHILLER SYSTEM CONFIGURATION

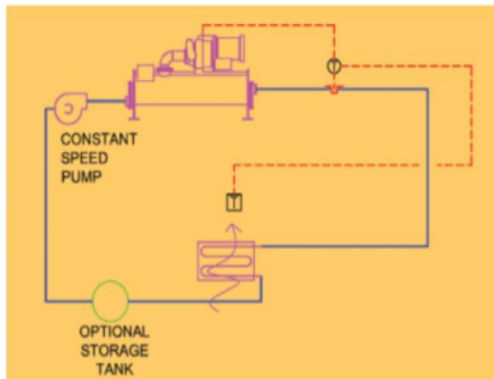
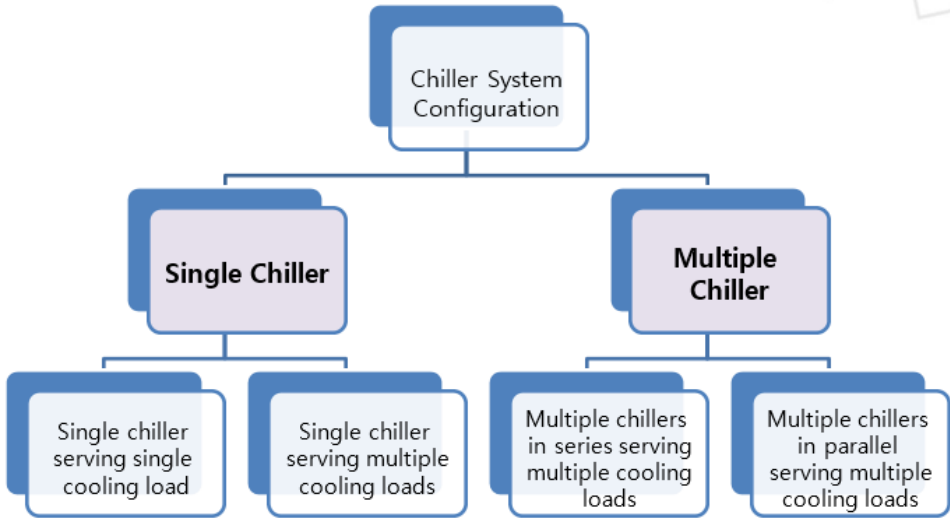

### SINGLE CHILLER SERVING A SINGLE COOLING LOAD IN A CONSTANT-FLOW SYSTEM

- The water is circulated between the evaporator and the cooling load using a constant-volume pump.
- Due to constant water flow, a reliable heat transfer takes place at the evaporator and the cooling coil.
- Chillers must have a sufficient volume of water in its piping system in order to prevent the unstable temperature variations and it may be an issue with single-chiller serving single coil.

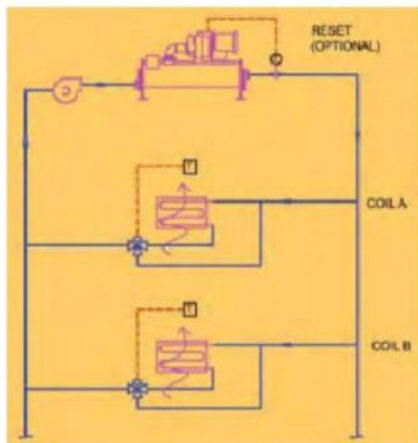

### SINGLE CHILLER SERVING MULTIPLE COOLING LOADS

- For plants with single chiller serving multiple cooling loads, a constant-flow chilled water system is cost-effective.
- Three-way valves are used at the cooling coils contribute to the variations in the flow.
- When these three-way valves adjust the flow according to the cooling load requirement, there are pressure drops and consequent flow variations.

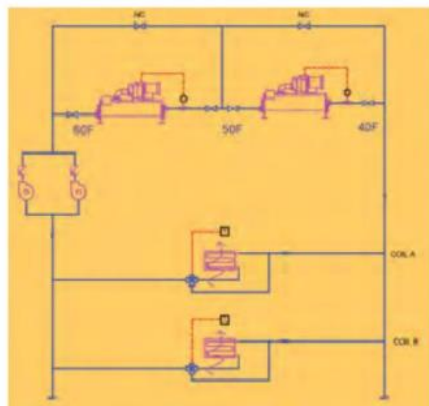

### MULTIPLE CHILLERS IN SERIES SERVING MULTIPLE COOLING LOADS

- The flow of water passes through each of the chiller in series.
- The first chiller is termed 'lead machine' and the second chiller in series is termed as 'lag machine'.
- When there is less requirement of cooling water, the lag machine is turned off and the lead machine performs the duty and provides the water at the required temperature.

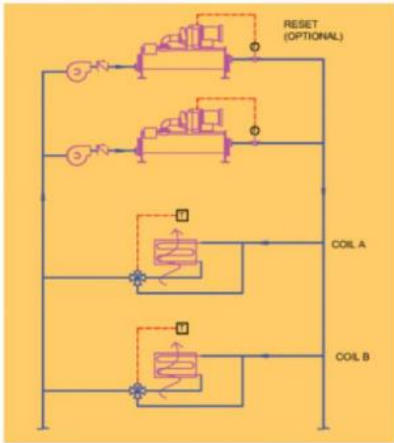

## MULTIPLE CHILLERS IN PARALLEL SERVING MULTIPLE COOLING LOADS

- The chilled water coming from each chiller is provided to each cooling load incorporated in the network.
- If there are two chillers arranged in parallel, the chilled water coming out from each of chiller is provided to every cooling loads; in this case Coil A and Coil B. incorporated in the network.
- If both the loads, Coil A and Coil B are to be run on full load requirement, then the system works efficiently.

## Cooling Load Estimates

- Chillers provide chilled water which is then used to provide air conditioning within buildings.
- The amount of cooling they produce varies
- How much cooling a chiller is producing or is able to produce  
=> Q

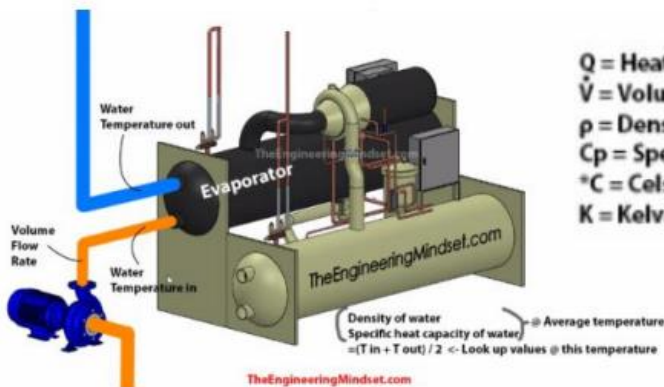

$Q$  = Heat transfer kW  
 $\dot{V}$  = Volume flow rate  $\text{m}^3/\text{s}$   
 $\rho$  = Density of Water  $\text{kg}/\text{m}^3$   
 $C_p$  = Specific Heat Capacity  $\text{kJ}/\text{kg}\cdot\text{K}$   
 $^{\circ}\text{C}$  = Celsius (Temperature)  
 $\text{K}$  = Kelvin (Temperature)

## 2.4 CHILLERS SELECTION CRITERIA

Criteria for chiller selection can be found in ANSI/ASHRAE/IESNA Standard 90.1 as follow

### 1. Efficiency Requirement

There are no federal minimum efficiency standards for chillers. However, ASHRAE (the American Society of Heating, Refrigerating, and Air-Conditioning Engineers) does provide efficiency specifications in its 90.1 standard, “Energy Standard for Buildings Except Low-Rise Residential Buildings,” which is used in many local building codes.

### 2. Number of Chillers

- Less than or equal to 300TR Capacity, 1 chiller unit
- Greater than 300TR but less than 600TR, 2 chiller units sized equally
- Greater than or equal to 600TR, two minimum chillers added so that no chiller is larger than 800TR, sized equally

### 3. Type of Chiller

- Less than or equal 100TR, reciprocating type
- Greater than 100TR but less than 300, screw type
- Greater than or equal 300TR, centrifugal type

Chillers use one of four types of compressor: reciprocating, scroll, screw, and centrifugal.

- reciprocating chillers are the least efficient.
- Screw and scroll compressors are typically used in applications needing up to 300 tons of cooling capacity.
- Centrifugal compressors traditionally provide larger capacities, although a new type of centrifugal compressor that employs magnetic bearings breaks this mold to serve the under 30 ton market

## 2.4 CHILLERS SELECTION CRITERIA

Medium sized buildings with a cooling load of around 200 – 400 tons of refrigeration or 700 – 1,400 kW will typically use screw compressors or Turbocor compressors.

- These can be either water or air cooled.
- These buildings might also use an absorption chiller if enough high quality heat is available.



Small building with cooling loads under 200 tons or 700 kW will typically use scroll compressors or Turbocor compressors and are typically of air-cooled design



## 2.5 ACHIEVING AND MAINTAINING CHILLER EFFICIENCY

- ❑ Chillers are one of the largest energy consumers within a building and this has a big impact on operational costs.
- ❑ It is important to monitor the chillers to assess the efficiency of the system and ensure optimal performance.

The energy efficiency of a chiller is commonly expressed in one of the three following rat

$$\text{Coefficient of performance COP} = \frac{\textit{kW refrigeration effect}}{\textit{kW input}}$$

$$\text{Energy efficiency ratio EER} = \frac{\textit{Btu/h refrigeration effect}}{\textit{Watt input}}$$

$$\text{Power per Ton kW/Ton} = \frac{\textit{kW input}}{\textit{Tons refrigeration effect}}$$

First calculate the kW/ton rating from the measured parameters. Use this data to calculate other energy efficiency parameters with the following relations

<b>COP = 0.293</b>	<b>EER = 3.413 COP</b>
<b>kW/Ton = 12/EER</b>	<b>EER = 12/(kW/Ton)</b>
<b>kW/Ton = 3.516 /COP</b>	<b>COP = 3.516 / (kW/Ton)</b>

Source : American Refrigeration Institute

## Coefficient Of Performance (COP)

- COP is a measure of the amount of power input to a system compared to the amount of power output by that system
- The higher the number, the more efficient the system is (dimensionless because the input power and output power are measured in Watt).

$$COP = \frac{\text{power output}}{\text{Power input}}$$

$$COP_{\text{maximum}} = \frac{\text{power output}}{\text{Power input}}$$

- TC is the cold temperature (°K)(outside)
- TH is the hot temperature (°K)(inside)

## Energy Efficiency Ratio (EER)

EER is the ratio of output cooling energy (BTU/h) to electrical input energy (Watt)

$$EER = \frac{\text{Output cooling power in BTU/h}}{\text{Input electrical power in W}}$$

## Kilo-watt Per Ton (KW/T)

- The efficiencies of large industrial air conditioner systems, especially chillers, are given in kW/ton to specify the amount of electrical power required for a certain cooling power.
- A smaller value represents a more efficient system.

$$kW/Ton = \frac{\text{ } }{\text{kW input}}$$

Tons refrigeration effect

## 2.6 EFFICIENT ELECTRIC CHILLER

- ❑ There are two types of devices, energy-transferring devices, and energy converters.
- ❑ The efficiency of a heat (energy) transferring device is called the coefficient of performance (COP).
- ❑ COP is also the ratio of Energy Output to Energy Input like energy efficiency (energy output is the amount of heat extracted from the heat source). The extracted energy is not a portion of the input energy. The extracted energy can exceed the input energy. Therefore, the efficiency of energy-transferring devices can be higher than 100%.
- ❑ In an energy converter, the output will be a portion of the energy input and it may be less than the energy input. Therefore, the efficiency will be less than 100% by the laws of thermodynamics.
- ❑ Electric chillers efficiency may be compared based on: The input power in kiloWatts required to deliver one ton of air conditioning (KW/Ton)
- ❑ Typical efficiency ranges along with sizes are given in the following tab

Compressor Type	Compressor KW/Ton	Sizes (Tons)
Air-Cooled		
Reciprocating	1.0 - 1.3	3 - 450
Centrifugal	0.7 - 0.9	80 - 1300
Screw	0.7 - 1.2	45 - 380
Scroll	up to 1.2	up to 60
Auxiliary KW/Ton = 0.19 KW/Ton		
Water-Cooled		
Reciprocating	0.8 - 0.9	3 - 450
Centrifugal	0.5 - 0.8	80 - 8500
Screw	0.6 - 0.7	50 - 1300
Auxiliary KW/Ton = 0.21 KW/Ton		

## 2.7 ACHIEVING AND MAINTAINING CHILLER EFFICIENCY

Many local building codes directly reference ASHRAE 90.1 or require using the international Energy Conservation Code, which has adopted 90.1

Chiller type	Capacity range					
	< 150 tons		150 to 300 tons		> 300 tons	
	Full load	IPLV	Full load	IPLV	Full load	IPLV
Centrifugal	0.703	0.670	0.634	0.596	0.576	0.549
Screw and scroll	0.790	0.676	0.718	0.628	0.639	0.572
Reciprocating	0.837	0.696	0.837	0.696	0.837	0.696

Note: IPLV = integrated part-load value.

Courtesy: E source; data from ASHRAE

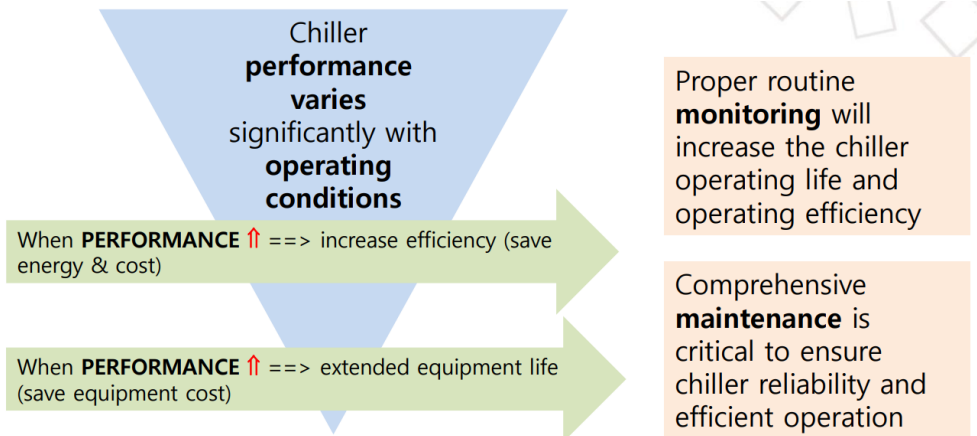

03

COOLING  
TOWER

## 3.0 INTRODUCTION TO COOLING TOWER

- ❑ Cooling tower is heating removal device.
- ❑ It can be found in industries such as power plants, chemical processing, steel mills, and many manufacturing companies where process cooling is necessary.
- ❑ Cooling tower cools down water that gets heated up by industrial equipment and processes. Water comes in the cooling tower hot (from industrial process) and goes out of the cooling tower cold (back into the industrial process).
- ❑ During the cooling tower working process, small volumes of water evaporate, lowering the temperature of the water that's being circulated throughout the cooling tower.



# 3.1 COOLING TOWER AND CHILLER

## COOLING TOWER

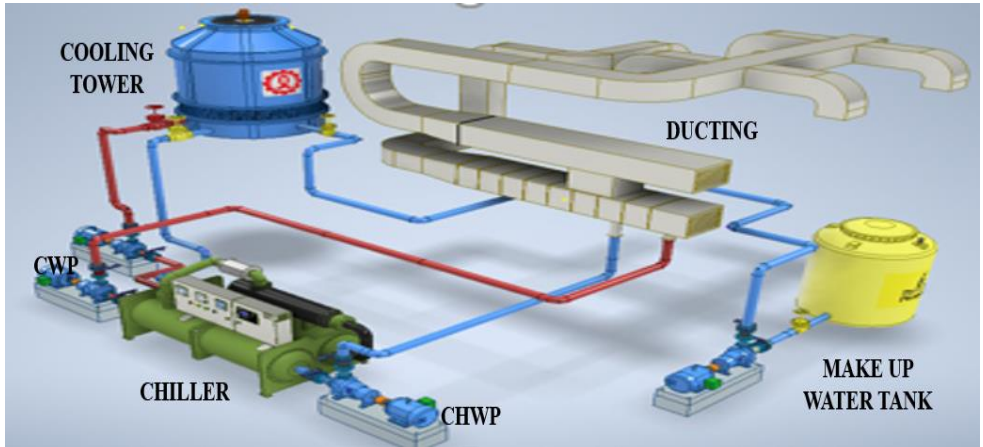

## CHILLER

Chiller	Cooling tower
Both a chiller and a cooling tower are used to remove heat from a liquid (coolant)	
located inside a building, often in the basement or another utility	sits on the roof of the building
absorb heat from a coolant, which is fully contained in a cooling system	removes heat from the water that is discharged from a condenser.
transfers heat to the air around the chiller unit	The discharged water is then recycled back into the plant to be used to cool the system again or discharged into the environment.

## 3.2 COOLING TOWER AND CHILLER OPERATION

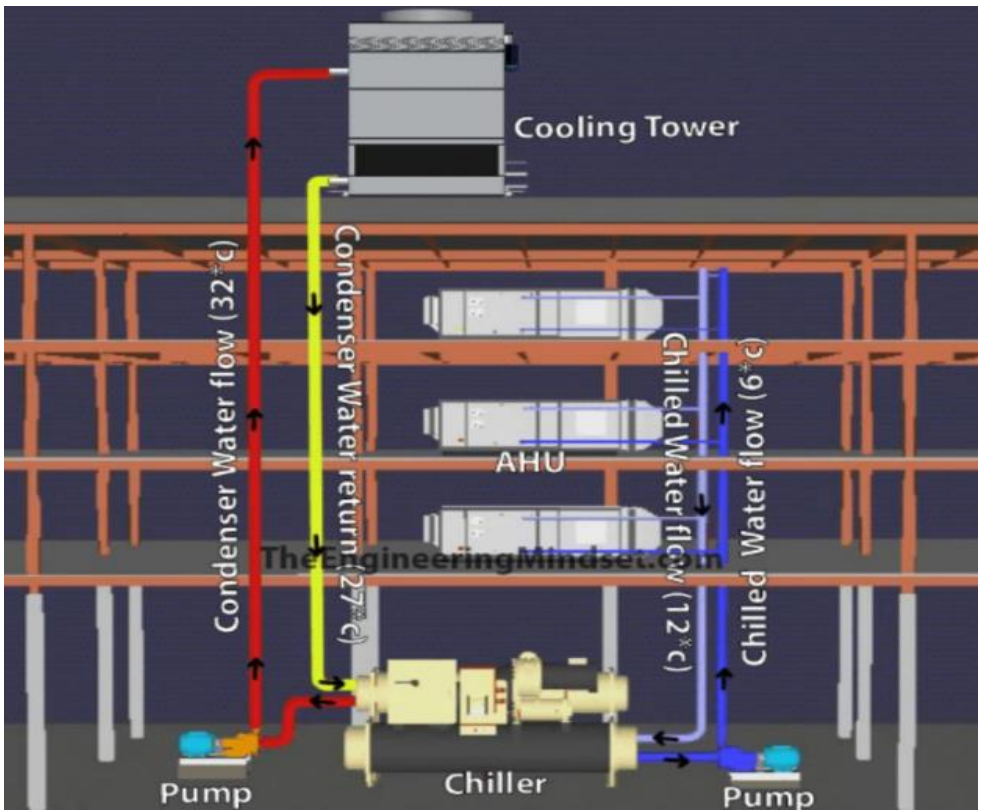

- ❑ A pump moves water (condenser water) between the chiller in the basement and the cooling tower on the roof.
- ❑ The chiller adds heat to the condenser water and the cooling tower cools it down by rejecting this into the atmosphere.
- ❑ The condenser water leaves the condenser of the chiller at around 32°C (89.6°F) and the pump sends this up to the cooling tower.
- ❑ The condenser water leaving the cooling tower and re-entering the chiller condenser, must be around 27°C (80.6°F)

### 3.3 TYPE OF COOLING TOWER

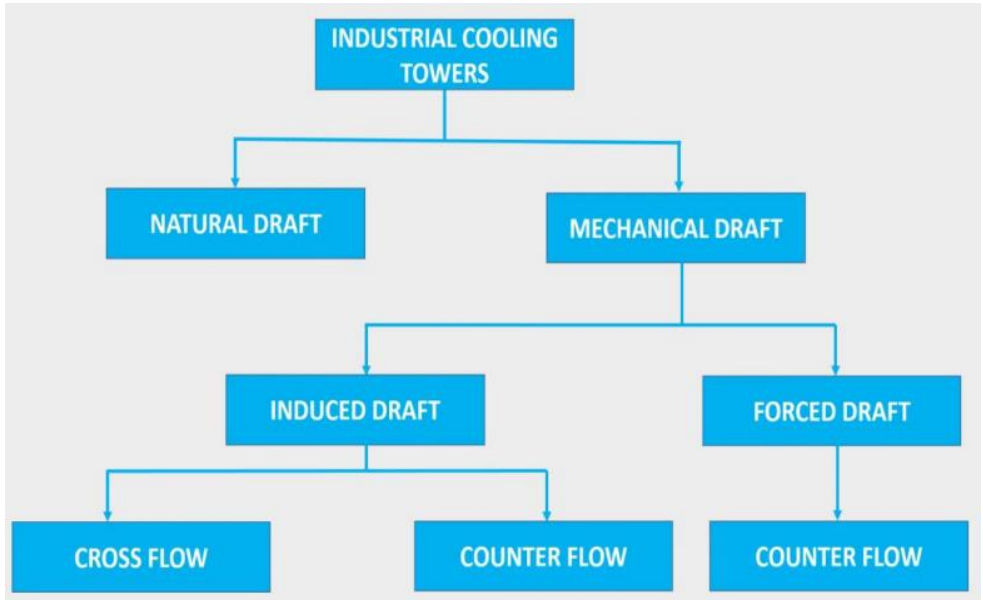

Natural Draft Cooling Towers



Mechanical Draft Cooling Towers

# 3.4 COOLING TOWER PART AND FUNCTION

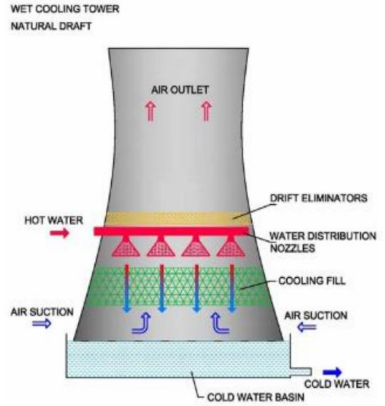
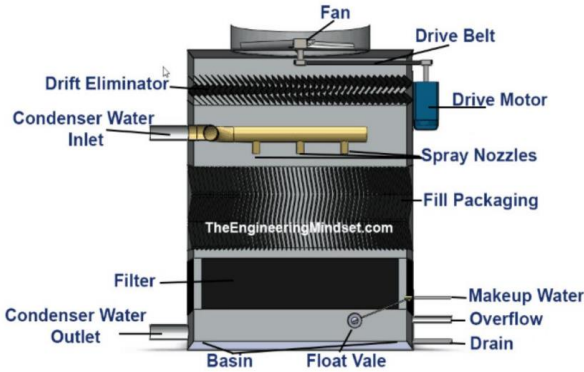

## Fill media

- maximize the surface area for evaporative cooling processes.
- Water gets distributed onto the fill, which spreads into thin film.
- This process increases the water-air interface and allows extra heat to evaporate at a fast pace.

## Eliminators

- captures water droplets that escape with air from the tower.
- Otherwise water would be lost to atmosphere.
- Ultimately drift eliminators save loss of water from cooling

## Fans

- force or push large amounts of air throughout the cooling tower

## Nozzles

- Used to spray water and wet the fill.
- allow for uniform distribution of hot water to achieve proper wetting of entire fill surface.
- allow for uniform distribution of the hot water that's inside a cooling tower

## Cold water basin

- receive cold water which is flow through the fills

## 3.5 COOLING TOWER PARTS AND OPERATION

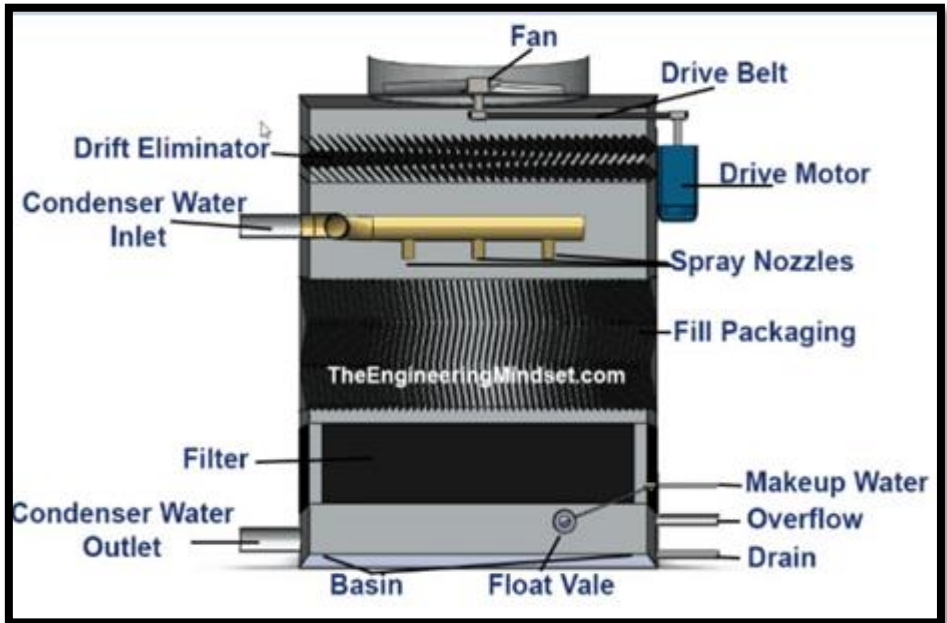

- The warm condenser water enters near the top of the cooling tower.
- It passes through some nozzles which spray the water in small droplets across the fill packaging.
- The spray increases the water's surface area which allows it to reject more heat.
- The water is sprayed across the fill packaging.
- These droplets, from the spray, run down the fill packaging causing a thin film of water on its surface.
- The water will evaporate into the air and carry heat away with it.

## 3.6 INDUSTRIAL COOLING TOWER

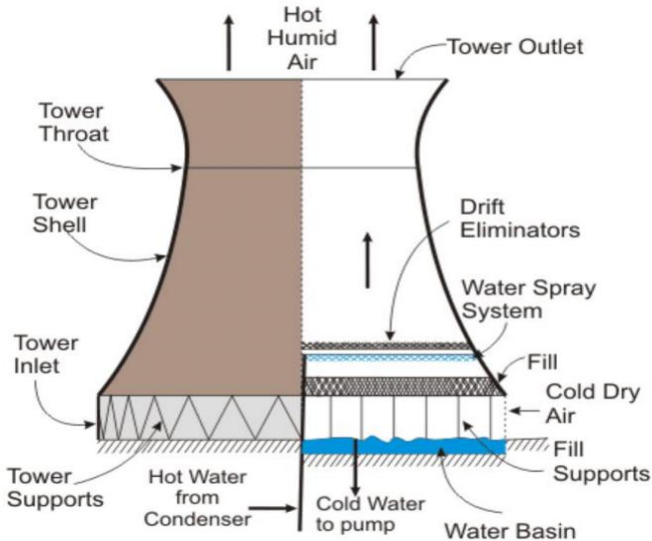

### A) Natural Draft Cooling Towers

- Usually used for large power plants and industries with infinite cooling water flow.
- The tower operates by hot air in the tower rising removing waste heat and then releasing it into the atmosphere.
- These towers are tall and have a hyperbolic shape to induce proper air flow.

- This type of cooling tower, fan is not used for circulating air.
- It is enclosing the heated air in the chimney, and it will create pressure difference between heated air and surrounding air.
- Because of this pressure difference air enters into the cooling tower.
- It requires large hyperbolic tower, so capital cost is high but operating cost is low because of absence of electrical fan.
- Two types of natural draft cooling tower: rectangular timber tower and reinforced concrete hyperbolic tower.

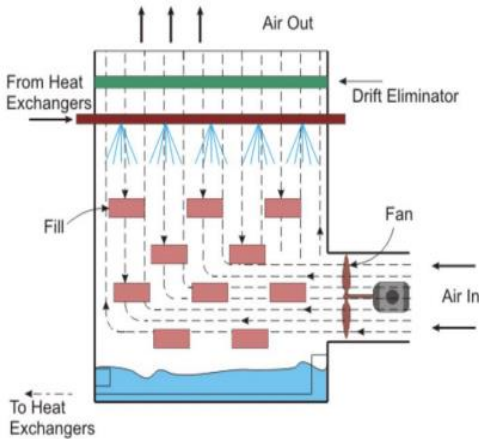

Forced draft cooling tower

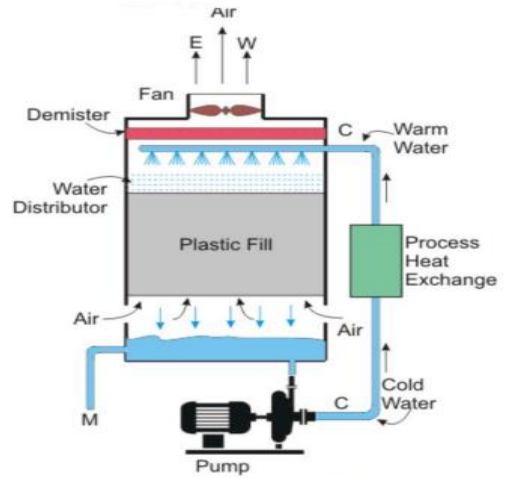

Induced draft cooling tower

## B) Mechanical Draft Cooling Towers

- Air forced through the structure by a fan that circulates air through the tower.
- Common fans used in these towers include propeller fans and centrifugal fans.
- More effective than natural draft towers, however they consume more power and cost more to operate as a result.
- Mechanical draft cooling towers utilize power driven motor fans to force or draw air through the tower.
- These large fans force or suck air through circulated water.
- The water then falls downward over fill surfaces, which helps increase the contact time between the water and the air and maximizes heat transfer between them.
- Induced draft cooling tower – contains vertical shaft and it is placed at top of the cooling tower.
- Forced draft cooling tower – contains horizontal shaft for the fan and it is placed at bottom of the tower.

## Mechanical Draft Cooling Tower

### Induced Draft towers

- ❑ typically mounted with a fan at the top of the cooling tower, which allows hot air out and pulls air throughout.
- ❑ Induced draft towers are more efficient as they use 30% to up to 75% less energy compared to forced draft designs.

### Forced Draft towers

- ❑ similar to induced draft.
- ❑ the basic difference is that the exhaust fan is placed at the base of the cooling tower, which allows the air to blow from the bottom.
- ❑ Their use is limited due to water distribution challenges, high horsepower fans and the
- ❑ possibility of re-circulation.

### Induced Draft Crossflow

### Induced Draft Counter flow Towers

#### A) Induced Draft Crossflow Towers

- ❑ The air flow horizontally through the fill and the tower's structure into an open plenum area.
- ❑ Hot water flows downward from distribution basins. There is less recirculation because the speed of exit air is higher than entering air.
- ❑ Fans and motor drive requirement her-proofing against moisture which can lead to freezing making it less efficient.

## B) Induced Draft Counterflow Towers

- ❑ Has a design where the air is vertically upwards and the counter current with hot water is falling downwards to cool the air.
- ❑ This allows for maximum performance out of each plan area and helps minimize pump head requirement.
- ❑ Less likely to ice up in cold weather conditions and can save energy in the long run.

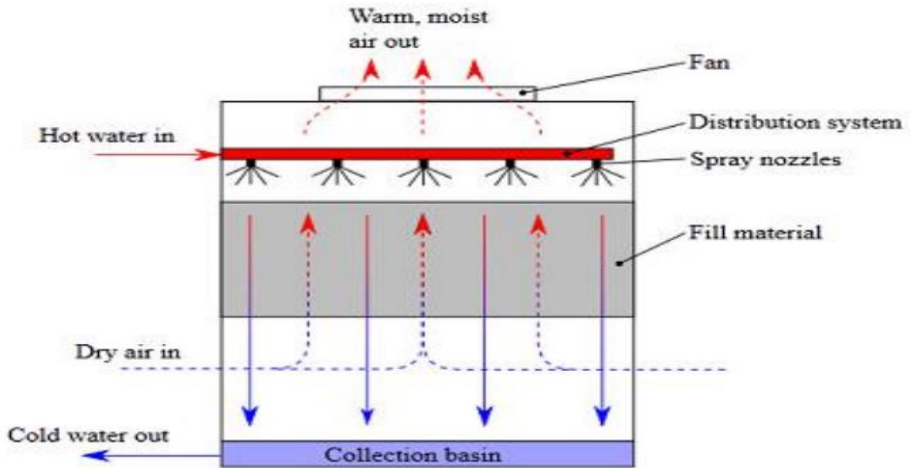

Counter-Flow Cooling Tower

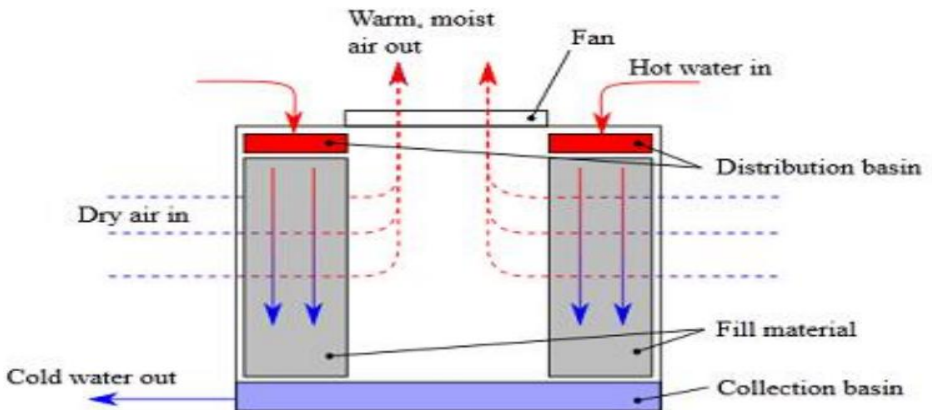

Cross-Flow Cooling Tower

## 3.7 FACTORS AFFECTING COOLING TOWER

- Capacity
- Range
- Approach
- Heat Load
- Wet bulb temperature
- Relationship range, flow and heat load
- Relation approach and wet bulb temperature
- Fills
- Pumps and water distribution
- Fans and motors

## 3.8 COOLING TOWER SELECTION

- Once a cooling tower is in place it is very difficult to significantly improve its energy performance.
- A number of factors influence the cooling tower's performance and should be considered when choosing a cooling tower:
  - a) Range
  - b) Approach
  - c) Cooling Capacity

### **Range**

- The difference between the cooling tower water inlet and outlet temperature.
- Range (°C) = inlet hot water temp (°C) – outlet cold water temp (°C)
- A high CT Range means that the cooling tower has been able to reduce the water temperature effectively and is thus performing well.

### **Approach**

- The difference between the cooling tower outlet cold water temperature and ambient wet bulb temperature.
- Approach (°C) = outlet cold water temp (°C) - wet bulb temp (°C)
- The closer the approach to the wet bulb, the better the cooling tower performance, the more expensive the cooling tower due to increased size.

### **Cooling Capacity, Q**

- The heat rejected in kCal/hr or TR or kW, given as product of mass flow rate of water, specific heat and temperature difference
- Q (kW) = mass flow rate x water specific heat x water density x temperature difference
- High cooling capacity, high cooling performance

$$\text{Cooling Tower Efficiency} = \frac{\text{Range}}{\text{Range} + \text{Approach}} \times 100$$

## 3.9 COOLING TOWER ENERGY EFFICIENCY

Energy Efficiency Opportunities:

1. Cooling tower selection
2. Fills
3. Pumps and water distribution
4. Fans and motors\*

Fans and motors

- A cooling tower uses pumps to circulate the water supply. The pumps consume a lot of power.
- The fans used in cooling towers also consume electrical power; however, the cooling towers provide significantly greater cooling capacity, which translates into greater energy efficiency cooling

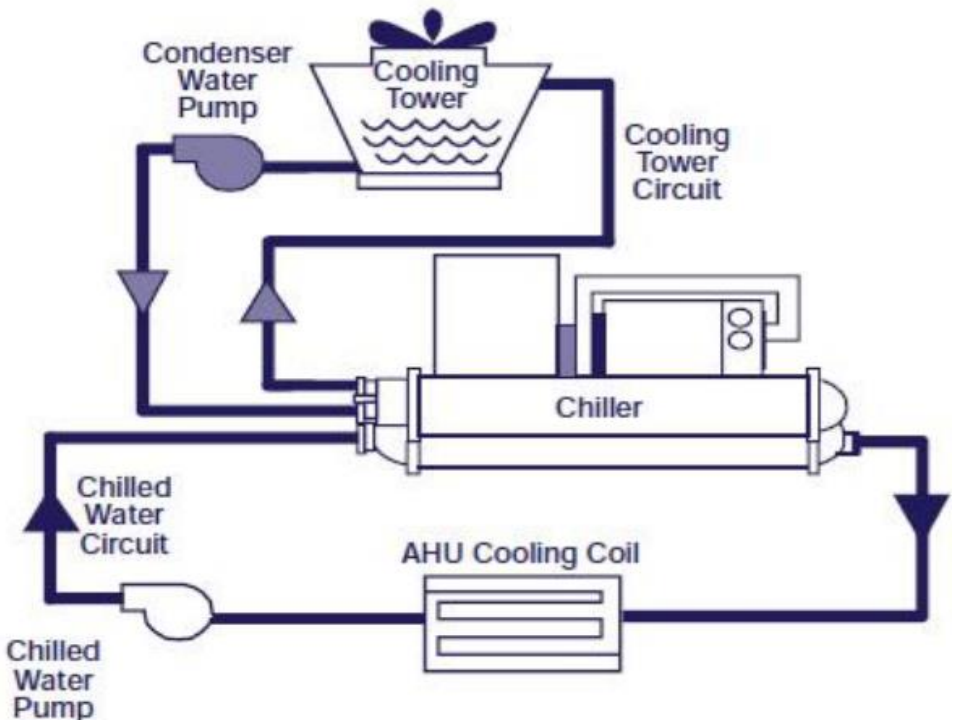

## 3.10 MAINTAINING COOLING TOWER EFFICIENCY

- ❑ Maintenance and water treatment are the most important factors affecting the life and energy-efficient operation of evaporative cooling equipment. Basic maintenance practices for the varying types of cooling systems:
- ❑ For a circulating water system, monthly cleaning and flushing the system. This prevents buildup of any solids in the system which can clog lines or make a breeding hot spot for bio-growth.
- ❑ Inspect and repair corrosion
- ❑ Check all the seals because a leak can lead to huge losses of water and chemicals, racking up the bill
- ❑ For Fan driven systems, make sure to keep the fan system in top operating condition.
- ❑ Check daily for any unusual vibrations or sounds, as this could mean there is a problem. The fan should be cleaned quarterly of heavy debris such as trash, bird droppings, or scale.
- ❑ Check for loose tighteners, missing balance washers, structural integrity and repair or replace any corroded hardware. Making sure the motor is operating smoothly is also key.
- ❑ Check to see that the motor is lubricated properly and is being cooled so it does not over heat, which can cause serious damage.
- ❑ Routine maintenance of the motor will help to ensure it has a long, useful life.

Finally, make sure to keep up with a water treatment plan. Water treatment plans can be the difference in having to replace something or not. When air and water contents enter the tower, they can build up, creating possible problems. Microbes can form, producing bio-growth that is unwanted, or corrosion could occur, which means replacing the affected parts. Both can add up to an expensive fix compared to the cost to treat the water

04

QUESTIONS  
AND  
TUTORIALS

# EXAMPLE 1

Density @ Avg Temp  
= 999.78kg/m<sup>3</sup>

Specific Heat @ Avg Temp  
= 4.19kJ/kg.K

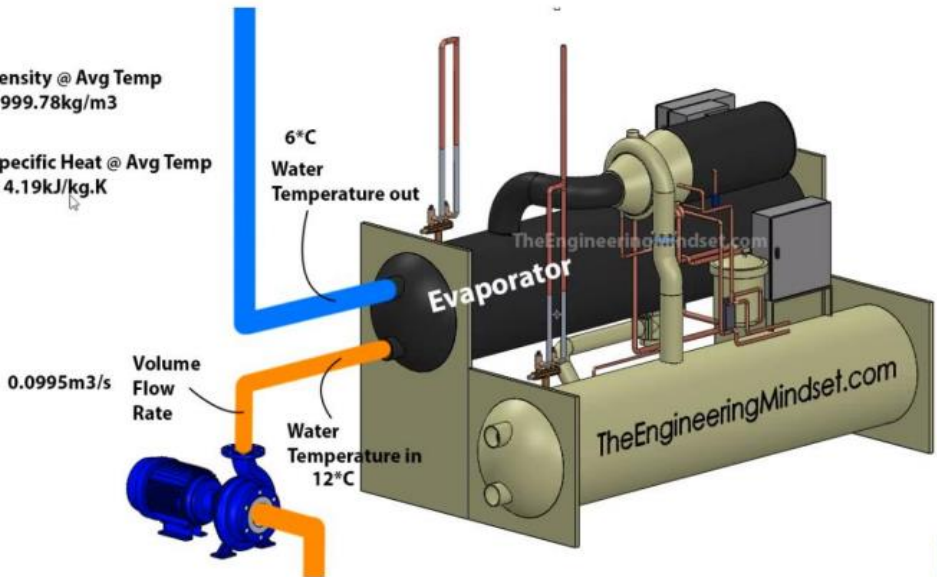

- The water flow rate of chilled water into the evaporator is 0.0995m<sup>3</sup>/s
- The inlet temperature is 12°C
- The outlet temperature is 6°C.
- This means the average temperature is 9°C
- So we lookup the water properties at this temperature
- Density of 999.78kg/m<sup>3</sup>
- Specific heat capacity of 4.19kJ/kg.K
- Find Cooling Load

# SOLUTION 1

---

**Formula:**  $Q = (\dot{V} \times \rho) \times C_p \times (\text{Water temperature at inlet} - \text{Water temperature at Outlet})$

---

$$Q = (0.0995 \text{ m}^3/\text{s} \times 999.78 \text{ kg/m}^3) \times 4.19 \text{ kJ/kg.K} \times ((12^\circ\text{C} + 273.15\text{K}) - (6^\circ\text{C} + 273.15\text{K}))$$

$$Q = 99.48 \text{ kg/s} \times 4.19 \text{ kJ/kg.K} \times ((12^\circ\text{C} + 273.15\text{K}) - (6^\circ\text{C} + 273.15\text{K}))$$

$$Q = 99.48 \text{ kg/s} \times 4.19 \text{ kJ/kg.K} \times (285.15\text{K} - 279.15)$$

$$Q = 99.48 \text{ kg/s} \times 4.19 \text{ kJ/kg.K} \times 6\text{K}$$

$$Q = 2500 \text{ kW (Refrigeration effect)}$$

$$\text{RT} = 2500 \text{ kW} / 3.517 = 711 \text{ Refrigeration Tons}$$

$$\text{BTU/h} = 2500 \text{ kW} \times 3412.142 = 853357 \text{ BTU/h}$$

- ❑ A ton of refrigeration (TR), also called a refrigeration ton (RT), is a unit of power to describe the heat-extraction capacity of refrigeration and air conditioning equipment
- ❑ \* BTU stands for British Thermal Unit, which is the unit used to measure thermal (heat) energy. Specifically, it is the amount of energy needed to raise 1 pound of water

### EXAMPLE 2

An air conditioning system is cooling a room to 23°C (73.4°F). If the outside air temperature is 32°C (89.6°F), find the maximum efficiency, COP

### Solution

Theoretical maximum efficiency,  $COP_{max} = \frac{(23 + 273.15)}{(32 + 273.15) - (23 + 273.15)} = 32.9 \#$

### EXAMPLE 3

An air conditioning unit has cooling capacity of 5 tons and an EER of 11.6. Find out how much is the input power

### Solution

Cooling capacity,  $Q \text{ (kW/ton)} = \frac{12}{EER} = \frac{12}{11.6} = 1.0344$   
kW/ton# Input power (kW) =  $Q \text{ (kW/ton)} \times RT = 1.0344 \times 5 = 5.17$   
kW#

### EXAMPLE 4

If 1 kW power is needed by a chiller to provide 1.95 kW of cooling in a space, find chiller's refrigeration ton in kW/ton

### Solution

Cooling capacity,  $Q \text{ (kW/ton)} = \frac{\text{Input power (kW)}}{\text{output power (RT)}} = \frac{1}{0.284} = 3.52 \text{ kW/ton\#}$

## QUESTION

### EXAMPLE 5

inlet hot water temp ( $^{\circ}\text{C}$ ) =  $42^{\circ}\text{C}$

outlet cold water temp ( $^{\circ}\text{C}$ ) =  $35^{\circ}\text{C}$

wet bulb temp ( $^{\circ}\text{C}$ ) =  $25^{\circ}\text{C}$

Find Approach, range and cooling tower efficiency

### Solutions 5

Approach = Cold water – wet water

$$= 35^{\circ}\text{C} - 25^{\circ}\text{C}$$

$$= 10^{\circ}\text{C}$$

Range = Hot water temperature – cold water temperature

$$= 42^{\circ}\text{C} - 35^{\circ}\text{C}$$

$$= 7^{\circ}\text{C}$$

Cooling tower efficiency =  $\text{Range} / (\text{Range} + \text{approach}) \times 100$

$$= 7^{\circ}\text{C} / (7^{\circ}\text{C} + 10^{\circ}\text{C}) \times 100$$

$$= 41.17\%$$

### EXAMPLE 6

Design conditions of cooling tower is:

Flowrate = 2500 l/hr

$$= \frac{\text{m}^3}{3600 \text{ s}}$$

$T_{\text{in}}$  =  $80^{\circ}\text{C}$

$T_{\text{out}}$  =  $40^{\circ}\text{C}$

### Solution 6

$Q = 2.5 \text{ m}^3/\text{s} \times 4.187 \text{ kJ/kg}^{\circ}\text{C} \times 1000 \text{ kg/m}^3 \times (80-40)^{\circ}\text{C}$

$$= 116 \text{ kW}$$

# TUTORIAL

1. Explain the function of a cooling tower.
2. Elaborate the meaning of Energy Efficiency Ratio (EER) of a chiller.
3. Elaborate the meaning of Coefficient of Performance (COP) of a chiller.
4. Derive how regular maintenance and monitoring of a pump can maintain and increase its efficiency. Describe how air-cooled chiller rejects unwanted heat.
5. Energy efficient chiller is selected based on its cooling capacity. Discuss the
6. Required criteria of chiller that are suitable for a building with a cooling capacity of 300TR. Calculate the efficiency of a cooling tower if inlet hot water temperature is 42°C, wet bulb temperature is 25°C and approach is 9°C.
7. Determine **TWO (2)** operational managements for a condenser to ensure it is always in a good performance and energy efficient.
8. Derive how regular maintenance and monitoring of a pump can maintain and increase its efficiency.
9. A plant requires an air maximum demand of 3,066 cfm for a compress air system. There are **TWO (2)** options of compressor available. The compressor will run 8000 hours per year. The **TWO (2)** option as show in table Below:-

Table 1

Compressor Option	Option 1	Option 2
	Two (2) medium size compressor/	One (1) medium Compressor (specification as in Option 2) + One (1) compressor with VSD (parameters listed below)/
<b>Delivered Flow</b>	1,5001cfm	498 – 1,728cfm
<b>Full Load Power</b>	250 kW	86 – 302kW
<b>Specific Power</b>	0.1672kW/cfm	Variable
<b>Unload Power</b>	50kW	-

11. An office building is currently fitted with **TWO (2)** units 500 Refrigerant Ton (RT) Chillers with specifications as table B2.

Table 2

Specification	Old	New
Capacity	: 500 RT (each)	: 500 RT (each)
Refrigerant Type	: R11	: R134a
Average Efficiency	: 0.83kWe/RT	: 0.62kWe/RT
Evaporator in/out temperature	: 44/54 F	: 44/54 F
Flowrate	: 1,200 USGPM	: 1,200 USGPM
Condenser in/out temperature/	: 87/97 F	: 87/97 F
Flowrate	: 1,500 USGPM	: 1,500 USGPM
Maintenance cost per year	: RM84,000	: RM60,000

The chiller operates 12 hours daily, 276 days per year and a diversity factor of 0.8. The office building is charge by TNB with C1 Tariff as the maximum demand is RM19.50 per kW and energy charge at RM0.234 per kWh.

The current chiller is considered aging and the R11 refrigerant has also phased out. Since air conditioning is a must in the building, the chiller needs to be replaced with **TWO (2)** new energy efficiency chiller units. The cost of replacement is RM 1,100,000. The new chiller specification is show in table B2. Analyze the energy saving and return of investment (ROI) for the replacement of the new chiller

QUESTION  
ANSWER



05

# GLOSSARY

# GLOSSARY

Refrigeration	A process of transferring heat from a low temperature region to a high temperature region
Air-Conditioning	The Process of controlling and maintaining the properties of air like temperature, humidity, purity, direction of flow etc
Chiller	Mechanical device that is used to cool down fluids or air. It removes heat from a substance through a refrigeration cycle, typically using a compressor, condenser, evaporator, and expansion valve.
Cooling Capacity	The amount of heat energy that it can remove from a substance in a given time. It is usually measured in tons or kilowatts (kW).
Compressor	The compressor is a key component of a chiller that increases the pressure and temperature of the refrigerant gas. It helps circulate the refrigerant through the chiller system.
Air-Cooled Chiller:	A type of chiller that uses ambient air as the cooling medium for the condenser. It eliminates the need for a separate condenser water system, making it suitable for smaller installations or locations where water availability is limited.
Water-Cooled Chiller	Relies on a separate condenser water system to remove heat from the condenser. It typically requires a cooling tower or cooling water source to dissipate heat, making it more suitable for larger installations with higher cooling demands

# GLOSSARY

Condenser	Releasing heat from the refrigerant and converting it from a high-pressure gas to a high-pressure liquid. It is usually located outside the chiller and uses a fan or water source to dissipate heat.
Evaporator	The evaporator is where heat transfer occurs in a chiller. It facilitates the absorption of heat from the substance being cooled, causing the refrigerant to evaporate and absorb the heat energy
Expansion Valve	A device that controls the flow of refrigerant from the high-pressure side of the chiller to the low-pressure side. It regulates the refrigerant's pressure and temperature, enabling efficient cooling
Refrigerant	A chemical substance that circulates through the chiller system, alternately absorbing and releasing heat energy to achieve cooling. Common refrigerants include hydrofluorocarbons (HFCs) such as R-410A and R-134a.
Condenser Water	The external water source used to remove heat from the chiller's condenser. It absorbs the heat from the refrigerant and carries it away, usually through a cooling tower or heat exchanger.
Ton of Refrigeration (TR)	Unit of cooling capacity that represents the amount of heat energy required to melt one ton (2,000 pounds) of ice in 24 hours. It is equivalent to approximately 12,000 British thermal units (BTUs) per hour or 3.516 kilowatts (kW).

## GLOSSARY

Condenser	Releasing heat from the refrigerant and converting it from a high-pressure gas to a high-pressure liquid. It is usually located outside the chiller and uses a fan or water source to dissipate heat.
Chilled Water	Cooled water produced by a chiller. It is commonly used in air conditioning systems or industrial processes to cool and dehumidify air or cool equipment.
Coefficient of Performance (COP):	A measure of a chiller's efficiency. It is calculated by dividing the cooling capacity by the power consumed by the chiller. A higher COP indicates a more efficient chiller.
Load Profile	Representation of a building or system's cooling requirements over a specific period. It shows the variations in cooling demand throughout the day or year, helping to determine the appropriate chiller size and operation..
Chiller Plant	A chiller plant refers to a collection of chillers, associated equipment (such as pumps, cooling towers, and controls), and distribution systems used to provide cooling for a building or industrial facility.
Variable Refrigerant Flow (VRF) System	A type of chiller system that uses refrigerant as the cooling and heating medium. It can vary the refrigerant flow rate to individual indoor units, providing precise temperature control and energy efficiency.

## GLOSSARY

Chiller Efficiency Ratio (CER):	A performance metric that compares the chiller's cooling capacity to the power consumed. It is calculated by dividing the cooling capacity in tons by the power input in kilowatts. A higher CER indicates a more efficient chiller.
Cooling Tower	Heat rejection device that removes excess heat from a building or industrial process by evaporating a small portion of the water in the system. It helps cool down water that has absorbed heat from various sources, such as chillers or industrial equipment.
Heat Exchange	The process by which heat is transferred from one medium to another. In the case of a cooling tower, heat exchange occurs between the hot water and the surrounding air as the water is sprayed or circulated over the tower's fill material.
Fill Material	A structure inside a cooling tower that provides a large surface area for the hot water to come into contact with the air. It promotes efficient heat transfer by maximizing the water's exposure to the airflow and facilitating evaporation.
Fan	Mechanical device in a cooling tower that generates airflow. It draws ambient air into the tower and directs it over the fill material, facilitating the cooling process by increasing evaporation and heat dissipation.

# GLOSSARY

Drift Eliminator	A component in a cooling tower that helps minimize the amount of water droplets carried out of the tower with the exhaust air. It reduces water loss and prevents the release of potentially harmful chemicals or contaminants.
Water Distribution System	System in a cooling tower is responsible for evenly distributing the hot water over the fill material. It ensures proper coverage and contact between the water and the air for effective heat transfer.
Makeup Water	The fresh water added to a cooling tower system to compensate for water loss due to evaporation, drift, and blowdown. It helps maintain the desired water level and quality within the cooling tower.
Blowdown	The process of removing a portion of the cooling tower's water to control the concentration of impurities and maintain water quality. It helps prevent the accumulation of dissolved solids that can lead to scaling or corrosion.
Cooling Tower Efficiency	The effectiveness of a cooling tower in removing heat from the circulating water. It is typically measured by the temperature difference between the entering and exiting water, as well as the cooling tower's approach and range.
Approach	The temperature difference between the cold water outlet and the wet-bulb temperature of the air entering the cooling tower. A lower approach indicates a more efficient cooling tower.

## GLOSSARY

Range	The temperature difference between the hot water inlet and the cold water outlet of the cooling tower. It represents the heat rejection achieved by the cooling tower.
Evaporative Cooling	The primary mechanism by which a cooling tower lowers the temperature of the water. It involves the evaporation of a small portion of the water, which absorbs heat from the remaining water and reduces its temperature.
Dry Cooling Tower	Also known as an air-cooled condenser, is a type of cooling tower that uses air alone to cool the circulating water. It eliminates the need for water evaporation and is suitable for areas with water scarcity or environmental restrictions.
Wet Cooling Tower	A traditional cooling tower that relies on the evaporation of water to cool down the circulating water. It is more commonly used in industrial applications and areas where water availability is not a concern.
Fan Stack	A structure in a cooling tower that houses the fan or fans responsible for generating airflow. It provides support and stability to the fan while directing the air over the fill material.
Fan Motor	The fan motor is an electric motor that powers the fan in a cooling tower. It converts electrical energy into mechanical energy to rotate the fan blades and generate airflow.

## REFERENCE

Kanoğlu, Mehmet, and Yunus A. Çengel. 2020. Energy Efficiency and Management for Engineers. 1st ed. New York: McGraw-Hill Education.

Rex Miller (2011). Air conditioning and Refrigeration. Second Edition, New York: Mc Graw-Hill

Stephen L. Herman, Bennie L. Sparkman. (2009). Electricity and Controls for HVAC/R. International Edition. Clifton Park, United States: Cengage Learning, Inc.

Theodore Wildi (2013). Electrical Machines, Drives and Power Systems. Pearson New International Edition. Harlow, United Kingdom: Pearson Education Limited.

William C. Whitman, William M. Johnson, John A. Tomczyk, Eugene Silberstein (2016). Refrigeration & Air Conditioning Technology. Mason, OH, United States: Cengage Learning, Inc.

Frank Kreith, D.YogiGoswami (2007), Energy Efficiency and Renewable Energy, RC Press

COOLING SYSTEM, COOLING TOWER AND CHILLER

e ISBN 978-967-2897-99-6



POLITEKNIK PORT DICKSON

(online)